Crash during emergency landing, Phoenix Air, Learjet 35A, N521PA, Fresno, California, December 14, 1994

Micro-summary: This Learjet 35A crashed short of the runway following an emergency approach.

Event Date: 1994-12-14 at 1146 PST

Investigative Body: National Transportation Safety Board (NTSB), USA

Investigative Body's Web Site: <http://www.nts.gov/>

Cautions:

1. Accident reports can be and sometimes are revised. Be sure to consult the investigative agency for the latest version before basing anything significant on content (e.g., thesis, research, etc).
 2. Readers are advised that each report is a glimpse of events at specific points in time. While broad themes permeate the causal events leading up to crashes, and we can learn from those, the specific regulatory and technological environments can and do change. ***Your company's flight operations manual is the final authority as to the safe operation of your aircraft!***
 3. Reports may or may not represent reality. Many many non-scientific factors go into an investigation, including the magnitude of the event, the experience of the investigator, the political climate, relationship with the regulatory authority, technological and recovery capabilities, etc. It is recommended that the reader review all reports analytically. Even a "bad" report can be a very useful launching point for learning.
 4. Contact us before reproducing or redistributing a report from this anthology. Individual countries have very differing views on copyright! We can advise you on the steps to follow.
-

NATIONAL TRANSPORTATION SAFETY BOARD

WASHINGTON, D.C. 20594

AIRCRAFT ACCIDENT REPORT

CRASH DURING EMERGENCY LANDING
PHOENIX AIR
LEARJET 35A, N521PA
FRESNO, CALIFORNIA
DECEMBER 14, 1994

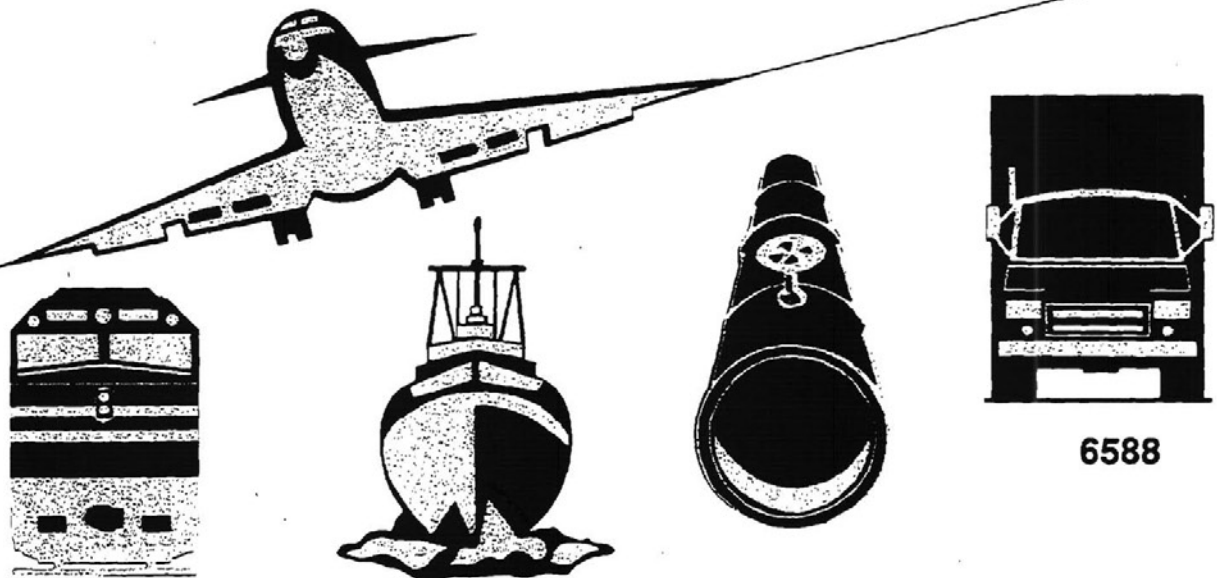

6588

The National Transportation Safety Board is an independent Federal agency dedicated to promoting aviation, railroad, highway, marine, pipeline, and hazardous materials safety. Established in 1967, the agency is mandated by Congress through the Independent Safety Board Act of 1974 to investigate transportation accidents, determine the probable causes of the accidents, issue safety recommendations, study transportation safety issues, and evaluate the safety effectiveness of government agencies involved in transportation. The Safety Board makes public its actions and decisions through accident reports, safety studies, special investigation reports, safety recommendations, and statistical reviews.

Information about available publications may be obtained by contacting:

National Transportation Safety Board
Public Inquiries Section, RE-51
490 L'Enfant Plaza, S.W.
Washington, D.C. 20594
(202)382-6735
(800)877-6799

Safety Board publications may be purchased, by individual copy or by subscription, from:

National Technical Information Service
5285 Port Royal Road
Springfield, Virginia 22161
(703)487-4600

NATIONAL TRANSPORTATION SAFETY BOARD

WASHINGTON, D.C. 20594

AIRCRAFT ACCIDENT REPORT

CRASH DURING EMERGENCY LANDING
PHOENIX AIR, LEARJET 35A, N521PA
FRESNO, CALIFORNIA
DECEMBER 14, 1994

Adopted: August 1, 1995
Notation 6588

Abstract: This report explains the accident involving the Phoenix Air Learjet 35A that crashed while attempting an emergency landing at Fresno Air Terminal, Fresno, California, on December 14, 1994. Safety issues in the report focused on maintenance, inspection and quality assurance. Safety recommendations concerning these issues were made to the Federal Aviation Administration, Phoenix Air, and the Department of Defense.

CONTENTS

EXECUTIVE SUMMARY	v
1. FACTUAL INFORMATION	
1.1 History of Flight.....	1
1.2 Injuries to Persons.....	11
1.3 Damage to Aircraft	11
1.4 Other Damage	11
1.5 Personnel Information.....	11
1.5.1 The Captain	12
1.5.2 The First Officer	13
1.6 Airplane Information.....	13
1.6.1 Aircraft Fueling Information	14
1.6.2 Weight and Balance and Stall Speeds	14
1.6.3 Maintenance Records.....	15
1.6.4 Airworthiness Directives.....	16
1.6.5 Installation of Special Mission Power Wiring	16
1.6.6 Interviews With Maintenance Personnel	20
1.6.7 Maintenance Actions Subsequent to the Accident.....	22
1.7 Meteorological Information	23
1.8 Aids to Navigation	24
1.9 Communications	24
1.10 Aerodrome Information.....	24
1.11 Flight Recorders.....	25
1.12 Wreckage and Impact Information.....	25
1.12.1 Airframe and Ground Damage	25
1.12.2 Cockpit	27
1.12.3 Airplane Systems	28
1.13 Medical and Pathological Information	29
1.14 Fire	30
1.15 Survival Aspects	35
1.16 Tests and Research	36
1.16.1 Flight Simulations	36
1.17 Organizational and Management Information.....	37
1.17.1 General.....	37
1.17.2 Maintenance.....	37
1.17.3 DOD Safety Survey.....	39
1.18 Additional Information.....	39
1.18.1 Crew Resource Management Training	39

1.19	New Investigative Techniques	40
2.	ANALYSIS	
2.1	General	41
2.2	The Fire	42
2.3	Airplane Handling.....	44
2.4	Maintenance Oversight	46
2.5	Survival Factors	48
3.	CONCLUSIONS	
3.1	Findings	49
3.2	Probable Cause	51
4.	RECOMMENDATIONS	52
5.	APPENDIXES	
	Appendix A--Investigation and Hearing.....	55
	Appendix B--Air Traffic Control Transcript.....	56
	Appendix C--FAA Forms 337 Regarding Special Mission Wiring Installation	64

EXECUTIVE SUMMARY

On December 14, 1994, about 1146:23 pacific standard time, a Phoenix Air Group, Inc. (Phoenix Air) Learjet 35A, registration N521PA, crashed in Fresno, California. Operating under the call sign Dart 21, the flightcrew had declared an emergency inbound to Fresno Air Terminal due to engine fire indications. They flew the airplane toward a right base for their requested runway, but the airplane continued past the airport. The flightcrew was heard on Fresno tower frequency attempting to diagnose the emergency conditions and control the airplane until it crashed, with landing gear down, on an avenue in Fresno. Both pilots were fatally injured. Twenty-one persons on the ground were injured, and 12 apartment units in 2 buildings were destroyed or substantially damaged by impact and fire.

The National Transportation Safety Board determines that the probable causes of this accident were: 1) improperly installed electrical wiring for special mission operations that led to an in-flight fire that caused airplane systems and structural damage and subsequent airplane control difficulties; 2) improper maintenance and inspection procedures followed by the operator; and, 3) inadequate oversight and approval of the maintenance and inspection practice by the operator in the installation of the special mission systems.

Safety issues in this report focused on maintenance, inspection and quality assurance. Safety recommendations concerning these issues were made to the Federal Aviation Administration, Phoenix Air, and the Department of Defense.

**Intentionally Left Blank
in Original Document**

NATIONAL TRANSPORTATION SAFETY BOARD
WASHINGTON, D.C. 20594

AIRCRAFT ACCIDENT REPORT

CRASH DURING EMERGENCY LANDING
PHOENIX AIR, LEARJET 35A, N521PA
FRESNO, CALIFORNIA
DECEMBER 14, 1994

1. FACTUAL INFORMATION

1.1 History of Flight

On December 14, 1994, about 1146:23 pacific standard time (PST),¹ a Phoenix Air Group, Inc. (Phoenix Air) Learjet 35A, registration N521PA, crashed in Fresno, California. Operating under the call sign Dart 21, the flightcrew had declared an emergency inbound to Fresno Air Terminal (FAT) due to engine fire indications. They flew the airplane toward a right base for their requested runway,² but the airplane continued past the airport. The flightcrew was heard on Fresno tower frequency attempting to diagnose the emergency conditions and control the airplane until it crashed, with landing gear down, on an avenue in Fresno. Both pilots were fatally injured. Twenty-one persons on the ground were injured, and 12 apartment units in 2 buildings were destroyed or substantially damaged by impact and fire.

N521PA was a public-use aircraft,³ under contract to the U. S. Air Force (USAF) to provide training for Air National Guard (ANG) fighters. The airplane had been modified with electronic equipment to satisfy the mission requirements. The mission was flown with a composite instrument flight rules/visual flight rules (IFR/VFR) flight plan, following IFR for the departure and approach and VFR in the operating area. Following an operational exercise with two California ANG F-16s in a restricted area east of the Sierra Nevada Mountain Range, the flight was being handled inbound by Fresno Approach Control (APC),

¹Unless otherwise indicated, all times are PST, based on a 24-hour clock.

²The right base would allow for a right turn to land on runway 29 right (29R).

³The Independent Safety Board Act Amendments of 1994, which became effective on April 23, 1995, altered the division between public and civil aircraft. Nevertheless, under either the former or current definition, N521PA was a public-use aircraft.

when, at 1141:36, the first officer⁴ reported out of 11,500 feet mean sea level (msl) for 11,000 feet, with "KILO."⁵ At 1143:10, the flight was instructed to fly a heading of 290 degrees and descend to and maintain 4,000 feet. At 1143:16, as the airplane was passing through about 9,200 feet msl,⁶ 10 nautical miles northeast of FAT, the first officer called, "declare an emergency, engine fire, immediate vectors."

The controller asked the flight which runway it wanted, "one one or two nine?" The first officer replied, "two nine, please." Dart 21 was given a heading of 230 degrees and cleared for a visual approach to 29R. At 1144:01, the approach controller informed the pilots that they were 6 miles from the airport, and at 1144:25, that the airport was 4 miles at 12 o'clock. The first officer replied, "the field in sight." Dart 21 was told to switch radio frequencies to tower. The first officer acknowledged the frequency change.

Dart 21 checked in with the tower controller at 1144:54. Almost immediately, the flight's intracockpit communications began to be carried on tower frequency. The communications between the captain and first officer (the only persons onboard), as well as cockpit background sounds, were carried continuously on tower frequency from that time until the airplane crashed. Static, sometimes loud enough to make it difficult to discern the pilots' voices, was heard during approximately the last 1 minute of flight.

About 1145:01, as Dart 21 was about 3 miles east-northeast of the approach end of 29R, on a track toward the southwest (see ground track and flight profile, from NAS Lemoore radar data and Fresno tower radio transmissions, figures 1a through 1c), the first officer stated, "I think you're gonna need to do a two seventy." At 1145:11, the captain stated, "we got an engine fire on the right side too, it shows." Radar data show that the airplane was flying at 280 knots ground speed, about 1,600 feet msl (the field elevation of FAT is 333 feet msl).

The tower controller acknowledged permission to make a 270 degree turn, although the tower supervisor later noted that he thought the statement was between the pilots and not a request to the tower. Radar data and witness

⁴Determinations of which pilot was speaking were made by other mission pilots, who knew both pilots on board Dart 21 and listened to the air traffic control recording. Two subsequent line corrections to the transcript were submitted by the father of the first officer. See appendix B.

⁵KILO was the automated terminal information service (ATIS) broadcast that was current for FAT.

⁶Inbound track, altitudes, and airspeeds were determined from radar recordings at Lemoore Naval Air Station (NAS Lemoore).

observations show that the flight turned to the south, as if beginning a 270 degree turn to the left, but the flight then turned back to a southwesterly track and crossed the extended centerline about 2 miles from the approach end of 29R. Radar contact was lost about 1145:38 as the airplane descended below 1,000 feet msl at 250 knots. The airplane impacted to the west on East Olive Avenue (E. Olive) in Fresno, approximately 2 miles west-southwest of the approach end of 29R. (Figures 2a and 2b are photographs of the accident site; and figure 2c is a wreckage path diagram.)

Tower personnel later demonstrated that they could observe the airplane for approximately 150 degrees of their field of view out of the tower windows, as it came in from the northeast, and passed to the east and south of the airport. They said that the airplane's pitch attitude was flat to low, and the airplane appeared low and fast throughout, until it slowed in the final seconds before impact. The tower controllers, assisted with field glasses, did not observe any smoke coming from the airplane. Some of the witnesses on the ground reported light gray smoke trailing from the airplane or from the right engine.

One tower controller recalled that as the airplane crossed the extended runway centerline, it was banked towards the runway. The supervisor recalled that the wings appeared nearly level at that time and the airplane continued nearly straight ahead. Two ANG pilots, who heard the fire/rescue equipment warning horn go off and rushed outside of the squadron building, saw the airplane about 1 1/2 miles from the approach end of 29R, about 200 feet above ground level (agl) in a steep right bank of about 60 degrees or more, overshooting final and not turning. They said "the nose [was] not tracking at all."

After the airplane passed to the southwest of the extended centerline, it appeared to tower controllers to gradually descend very low. The tower supervisor stated that the landing gear appeared to be down about that time. The airplane then climbed back up gradually from what appeared by line of sight to tower controllers to be above the tree tops. It then again gradually descended in an apparent westerly heading. The airplane climbed or "porpoised" up a second time, more severely. It then descended sharply until view was obstructed by trees. A fireball and smoke were then observed.

Witness observations varied regarding when the airplane began to slow. Most witnesses reported the airplane slowing and the wings rocking in the final seconds before impact, or during the final porpoise. One witness, about

2 miles east of the impact site, described the airplane as flying very low and rocking back and forth in a teeter-totter motion.

The second airplane porpoise, as seen from the tower, coincided with an observation by an elementary school teacher, who was at a school about 2 blocks east of the impact site. She observed the airplane come from a direction which was slightly north of E. Olive, on a track that was approximately west-southwesterly. It passed nearly overhead. She said that the airplane was very low, and that the only noises she recalled were the sounds of "fast wind." The airplane climbed above the school and cleared some approximately 60-foot-tall pine trees. It then descended sharply on the west side of the school. The impact was obstructed from her view by the school building.

Another witness was sitting in his van, parked at the south curb of E. Olive, immediately to the east of the intersection with North Sierra Vista Avenue (N. Sierra Vista) or slightly less than 2 blocks west of the impact site. He saw the airplane shortly before impact, coming nearly straight at him in a nose low and left-wing-down attitude. He saw the airplane impact near the intersection of E. Olive and N. Chestnut Avenue (N. Chestnut). He said that immediately after impact the airplane became a gigantic fireball. He did not see any pieces come out of the fireball, and thought that it was going to slide down the street into his van. The fireball, however, continued along the north side of E. Olive. After the fireball crossed the intersection with North Recreation Avenue (N. Recreation), he saw it ignite two apartment buildings that faced south on E. Olive in the 2-story Olivewood apartment complex.

Portions of the airplane, including the right wing, right engine, and empennage, came to rest on E. Olive. A substantial portion of the fuselage was consumed in fires located in and around the apartment buildings and associated foliage. The left engine came to rest in an unburned apartment unit.

Two buildings in the Olivewood apartment complex facing E. Olive sustained the most severe damage. Of the two apartment buildings, the one to the east or the first building in the impact path sustained primarily impact damage. The westerly building sustained both impact and fire damage, and some of the apartment units in that building were destroyed by fire. Lesser damage, primarily flash-fire and minor impact damage occurred to businesses on the north side of E. Olive.

Ground Track of DART 21 Lear 35A DCA-94-MA-007 Fresno, CA

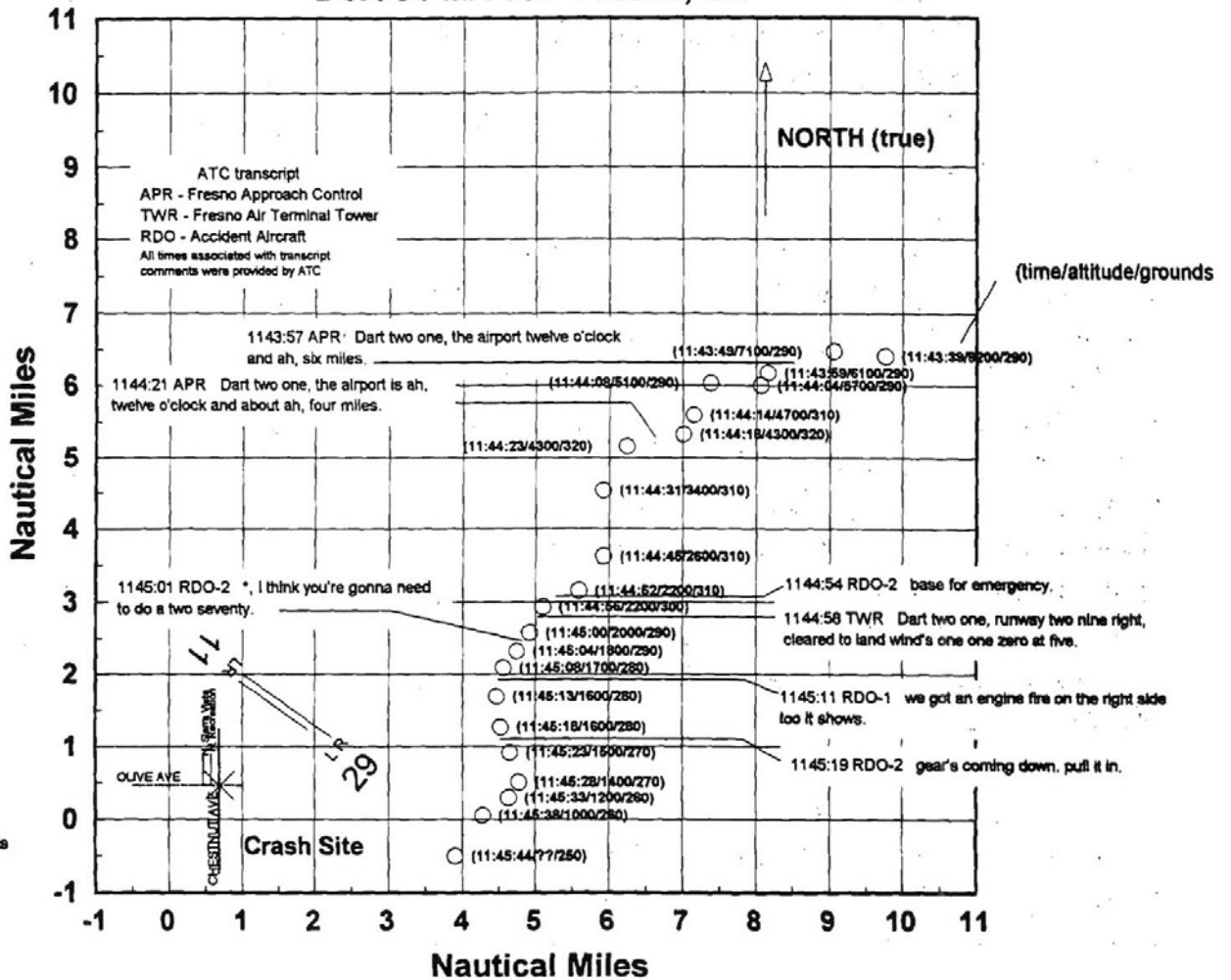

origin is
 36 45 00 N
 119 45 00 W
 which is SW
 corner of the Clovis
 quadrangle

Figure 1a.--Ground track.

Altitude vs Time DART 21 Lear 35A DCA-94-MA-007 Fresno, CA

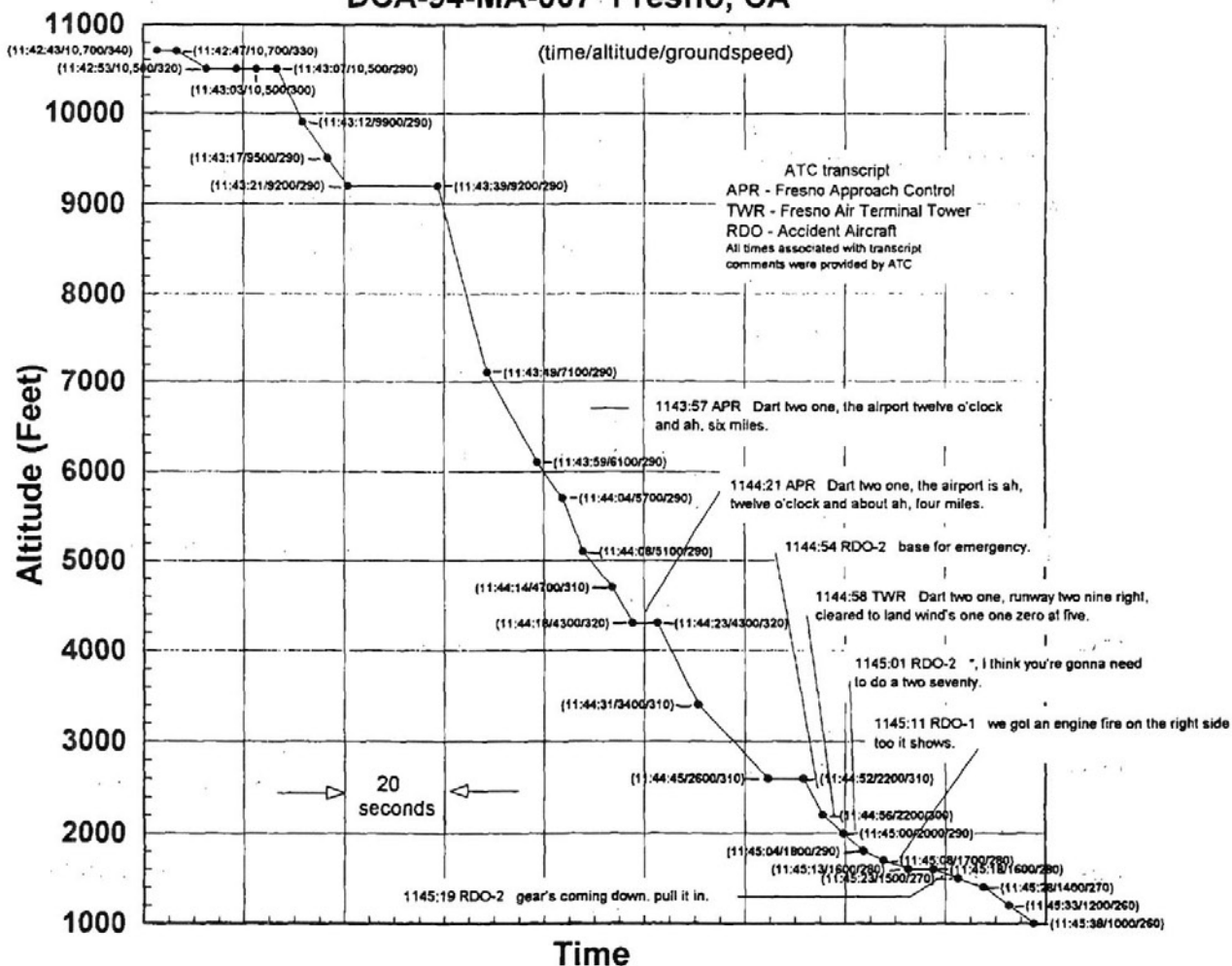

Figure 1b.--Altitude vs. time.

Altitude vs Time DART 21 Lear 35A DCA-94-MA-007 Fresno, CA

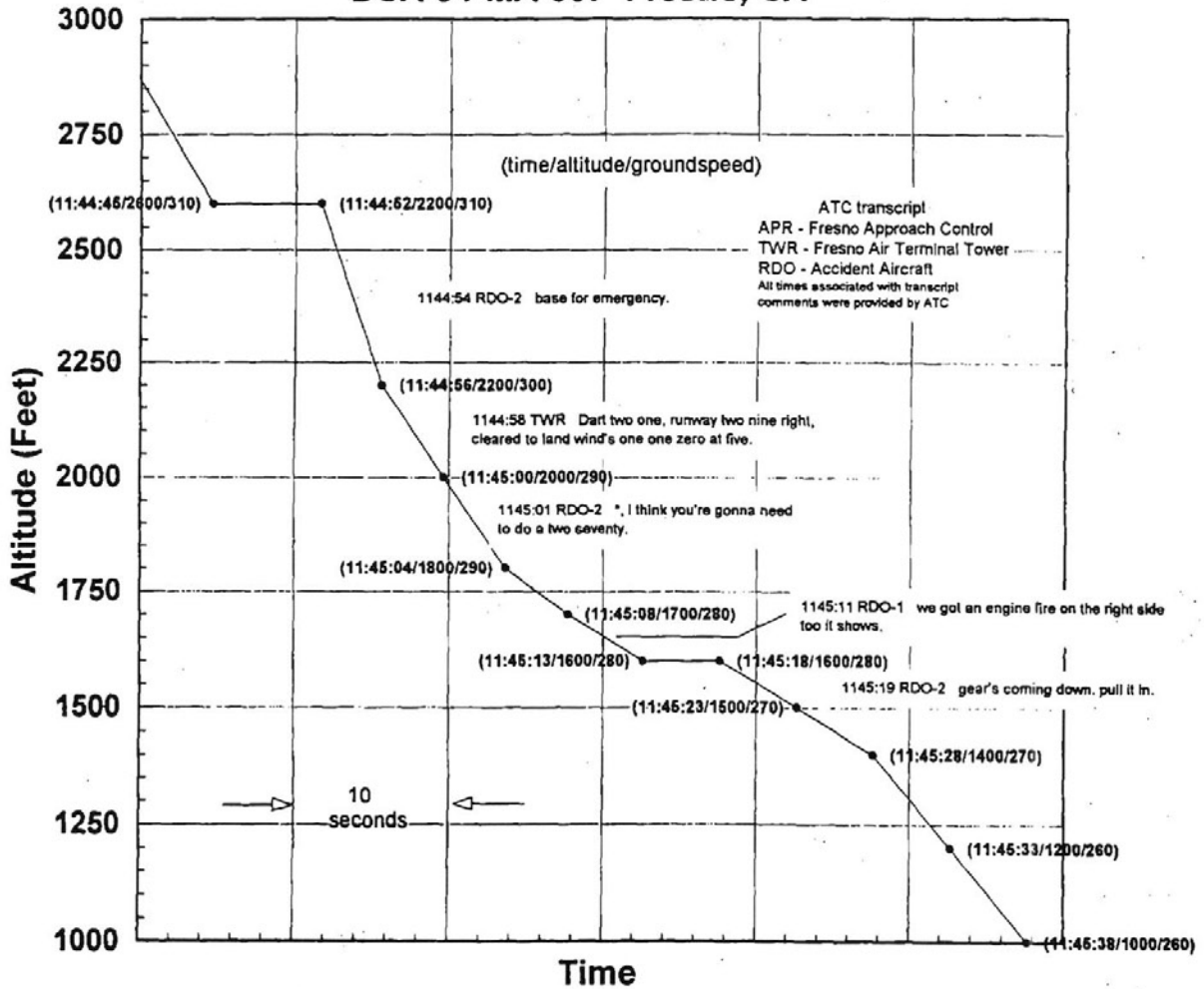
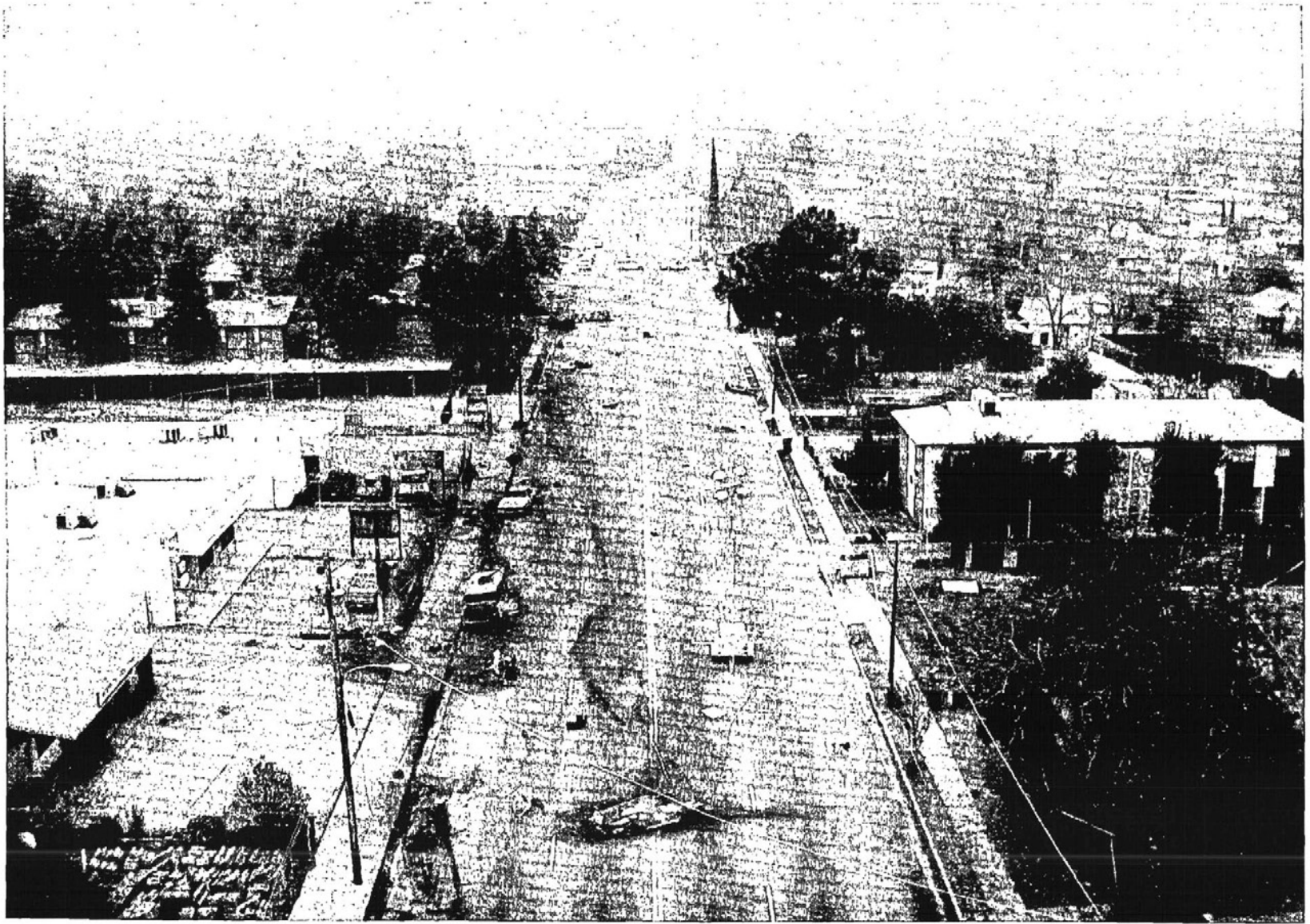

Figure 1c.--Altitude vs. time.



Figure 2a.--View to the west on E. Olive
looking approximately down the final flightpath.



Figures 2b.--View to the east on E. Olive from immediately east of N. Sierra Vista. Last major portions of wreckage in wreckage path are near the bottom of the photograph.

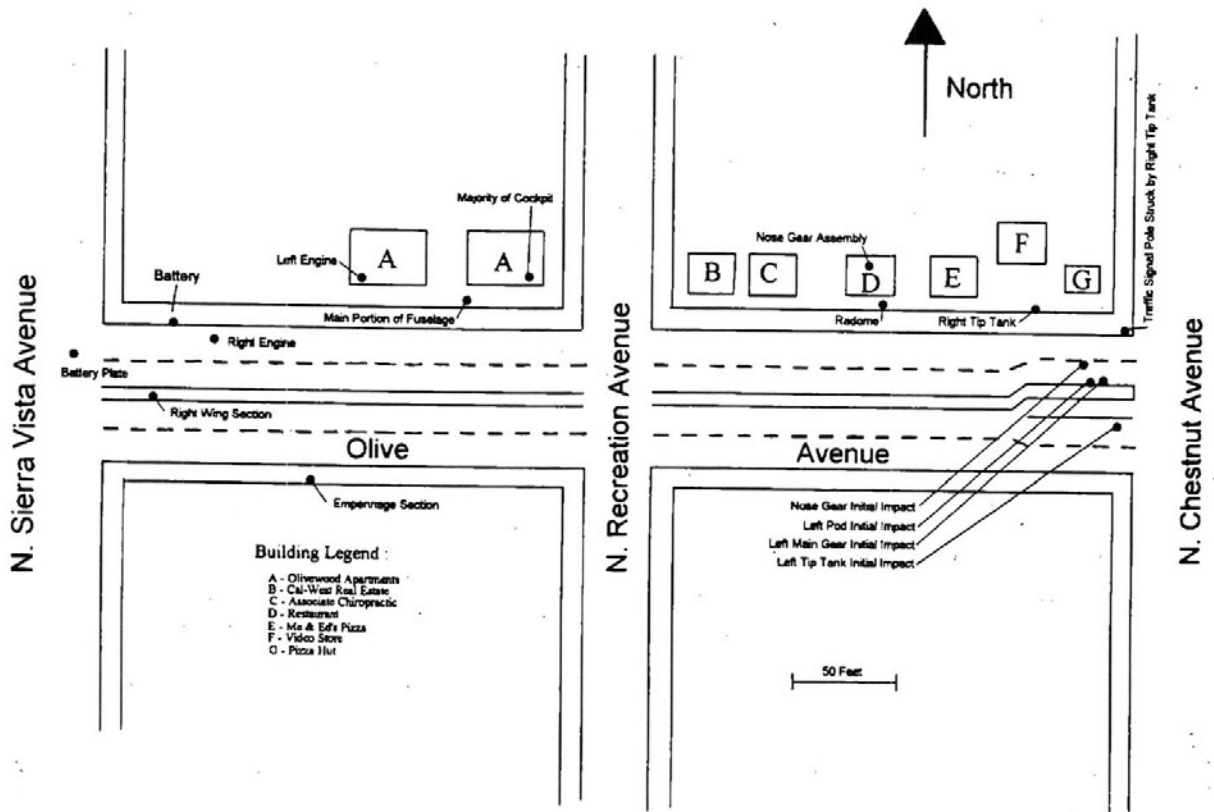

Figure 2c.--Wreckage path diagram.

Approximately 12 automobiles that were parked along the north curb of E. Olive were impacted by burning wreckage and were ignited and destroyed. E. Olive was generally clear of traffic in the 2-block wreckage path, and no persons in automobiles were seriously injured. Most of the 21 persons who were injured on the ground lived in units in the two damaged apartment buildings. One female resident sustained severe burn injuries.

Fresno police, fire, and rescue units began to arrive at the scene about 2 minutes after impact, and were assisted by units from FAT. Apartment and burning-wreckage fires were extinguished, site security and command were arranged, and an ambulance dispatch post was established.

Initial impact occurred about 1146:23, at 36 degrees, 45 minutes, 30 seconds north latitude, and 119 degrees, 44 minutes west longitude.

1.2 Injuries to Persons

<u>Injuries</u>	<u>Flightcrew</u>	<u>Cabincrew</u>	<u>Passengers</u>	<u>Other</u>	<u>Total</u>
Fatal	2	0	0	0	2
Serious	0	0	0	1	1
Minor	0	0	0	20	20
None	<u>0</u>	<u>0</u>	<u>0</u>	<u>=</u>	<u>0</u>
Total	2	0	0	21	23

1.3 Damage to Aircraft

The airplane was destroyed by the impact and fire. It was valued at \$1.3 million.

1.4 Other Damage

Public property damage was about \$10,000. Private property damage was about \$2 million.

1.5 Personnel Information

Both pilots were male, married, and resided in Klamath Falls, Oregon, where the airplane was based and maintained by the operator, Phoenix Air, at the

Oregon ANG facility at Kingsley Field, Klamath Falls International Airport (LMT). The pilots departed from their homes on the morning of December 13, 1995, and flew N521PA from LMT to FAT. At FAT, following a briefing with the locally based California ANG fighter squadron, they flew one mission on that afternoon. They logged 4.7 flight hours on December 13, before securing the airplane at the ANG facility at FAT for the night. They then checked into rooms in the nearby Ramada Inn, at about 2018. They checked out on December 14, about 0846.

1.5.1 The Captain

The captain of Dart 21 was 36 years old, born on March 23, 1958. He was hired as a Learjet first officer by the operator on July 1, 1990. He held a Federal Aviation Administration (FAA) Class I medical certificate, with no restrictions, dated April 27, 1994. His total pilot hours reported at the time of his last medical certification was 6,700. He held the following ratings: Airline Transport Pilot (ATP)/Multi-engine Land; Commercial/Single-engine Land; Rotorcraft - Helicopter/Commercial; Flight Instructor - Airplane Single Engine, Instrument Airplane. He held the following type ratings: BE-300, BE-1900, LR-Jet.

He was upgraded to the position of Learjet captain in November 1991. Prior to the accident flight, his total flying time was 7,109 hours. His total time in Learjets was 2,746.8 hours, including 1,954 hours as pilot-in-command. In the preceding 30, 60, and 90 days, he logged 56.4, 96.5, and 152.9 flight hours, respectively. His total instrument time was 261.7 hours, and his total night time was 843.2 hours.

FAA accident and incident records indicated that the captain was cited for a violation of 14 CFR Part 91.9 (Careless/Reckless) during an aborted takeoff on May 30, 1988, at Las Vegas International Airport, Nevada. The report indicated that he attempted to take off in a Cessna 402C, with the parking brake partially engaged. His airman's certificate was suspended for 14 days.

The captain received annual Learjet 35 recurrent training at Flight Safety International (FSI), in Tucson, Arizona, from October 3 through 6, 1994. He satisfactorily completed a proficiency check ride in accordance with 14 CFR 61.58 on October 6, 1994. According to FSI training records, the captain had problems with altitude control during the first three flights of the recurrent training. On the flight of October 4, 1994, the following remarks were noted: "Periodically

loses concentration on A/C (aircraft) control." On the flight of October 5, 1994, overall improvement was noted in the record, but the captain was noted as occasionally allowing the airspeed to wander, and there were occasional altitude deviations noted of more than 200 feet. The remarks pertaining to the proficiency check indicated that the flight was good.

1.5.2 The First Officer

The first officer, age 34, was born on August 8, 1960. He was hired by the operator on November 1, 1991. He held an FAA Class I medical certificate, with no restrictions, dated September 30, 1994. The total time reported on his last medical certificate application was 6,000 flight hours. Company records showed that he held the following ratings: ATP/Multi-engine Land and Commercial/Single-engine Land. He held the following type rating: LR-Jet. His total flight time prior to the accident flight was 5,268 hours. His total time in the Learjet was approximately 3,000 flight hours, including approximately 2,000 hours as pilot-in-command. In the last 30, 60, and 90 days prior to the accident, he logged 50.2, 95.2, and 145.4 flight hours, respectively. His total instrument time was 266.8 hours, and his total night time was 492.3 hours.

The first officer was upgraded to the position of Learjet captain in September 1992. He received annual recurrent training at FSI from October 3 through 6, 1994. He satisfactorily completed a proficiency check ride in accordance with 14 CFR 61.58 on October 6, 1994. The remarks recorded in the FSI training records contained the entries, "Very good all areas," "Strong performer throughout," and "Continued good work."

According to FAA accident and incident records, as the pilot of a Cessna 152, the first officer made a forced landing in a field in Hayward, California, on November 11, 1988, following an engine failure. There were no violations as a result.

1.6 Airplane Information

The airplane, a Learjet 35A, serial No. 239, was manufactured on April 7, 1979. It was exported to Australia on June 25, 1979, where it remained registered and was operated until August 25, 1992. It was returned to the United States, and was sold and consequently registered to Phoenix Air on September 17, 1992.

Prior to the accident flight, the airplane had accumulated 6,673.4 flight hours and 5,254 landings. The airplane was equipped with Garrett TFE731-2-2B turbofan engines. The left engine, serial No. 74682, accumulated 6,438.2 flight hours and 5,046 cycles. The right engine, serial No. 74209, accumulated a total of 8,439.9 flight hours and 6,088 cycles. (Section 1.17, Organizational and Management Information, contains background regarding the Phoenix Air maintenance program.)

1.6.1 Aircraft Fueling Information

The airplane departed LMT on December 13 with 5,600 pounds (823.5 gallons) of JP-8 aviation fuel. After arriving at FAT, the airplane was refueled with 565 gallons (estimated at 3,488.4 pounds) of MIL-T-83133 JP-8 at the ANG facility before it was flown in a mission with the California ANG. After it was returned to FAT, the airplane was secured. The following morning, the airplane was fueled at approximately 0917 with 513 gallons (estimated at 3,842 pounds) of JP-8. Both fuel sources at the ANG unit at FAT and at LMT used the same JP-8 fuel product with the same additives from the same supplier.

Immediately following the accident, the ANG maintenance unit at FAT secured all fuel trucks and storage tanks, including the truck used for both refuelings of N521PA. All samples tested within normal specifications and were found to be free of contamination.

1.6.2 Weight and Balance and Stall Speeds

The airplane type certificate listed the maximum allowable takeoff weight at 17,000 pounds. The maximum allowable structural landing weight was 14,300 pounds. The weight of the airplane at the time of the accident was estimated by the Safety Board using data derived from available weight and balance records, known fuel loads, and estimated fuel burn. Miscellaneous stores, including Jeppesen books, and personal items of the pilots, were estimated to weigh 200 pounds.

The estimated weights are as follows:

Basic operating weight:	11,195.2 pounds
Accident flight takeoff weight:	16,859.4 pounds
Total weight at the time of impact:	14,879.4 pounds

Due to the unknown distribution of fuel between the tanks in the airplane at the time of the accident, the center of gravity (CG) was determined to be within the following range:

Most forward CG = 14.4 percent mean aerodynamic chord
(MAC)

Most rearward CG = 23.46 percent MAC

Both extremes were within the allowable CG envelope for N521PA.

As part of the investigation, stall speeds were computed for the accident airplane, with mission equipment stores in place, at multiple flap settings. The speeds were:

Stall speed, flaps up = 118 knots

Stall speed, flaps at 8 degree position = 108 knots

Stall speed, flaps at 20 degree position = 104 knots

Stall speed, flaps at 40 degree position = 98 knots

Vmca (minimum control speed with critical engine inoperative, limitations in flight manual) = 112 knots

1.6.3 Maintenance Records

Safety Board investigators examined N521PA's maintenance records from the time of its manufacture to the date of the accident. The last calendar inspection prior to the accident was a 200-hour/6-month inspection on November 14, 1994, 50.4 flight hours before the accident flight. Preceding that, a 200/400/600/800/1,200-hour/6- and 12-month inspection was completed on July 25, 1994, 245.5 flight hours before the accident.

The Learjet inspection program changed on September 15, 1994. A revised inspection schedule moved inspection items required formerly at 200-hour intervals to new 150-hour interval zone inspections. Some items were increased to 300-hour interval inspections. The 400-hour interval inspection requirement was

deleted and inspection items from that inspection were moved either to 300-hour interval inspections or to new 600-hour interval inspections. Phoenix Air was converting to the new inspection program at the time of the accident, using the manufacturer's inspection program implementation instructions.

1.6.4 Airworthiness Directives

There were several Airworthiness Directives (ADs) applicable to N521PA; the maintenance records documented the accomplishment of those ADs. Two of the ADs addressed possible fire hazards in the tailcone area. They were:

- 1) AD 80-19-09 R1, which required the installation of Gates Learjet motive flow valve shrouds and drain lines in accordance with Modification Kit No. AMK 80-7. The purpose of the kit was to collect any fuel which leaked from the motive flow valve and to drain the fuel overboard. N521PA's records show that the modification was completed on the airplane on August 17, 1981.
- 2) AD 86-05-05 R1, which addressed relocation of the battery vent system. The relocation was to prevent fuel from entering the battery case. N521PA's records show that the AD was complied with on November 28, 1985.

A nonrequired alert service bulletin, which did not become an AD, recommended replacing the rubber alcohol pressurization line in the tailcone area with an aluminum line. This manufacturer's recommendation had not been installed on N521PA.

1.6.5 Installation of Special Mission Power Wiring

N521PA's logbook documented that on October 22, 1992, at an airplane total time of 5,284.8 flight hours, special mission power wiring was installed.⁷ The entry referenced FAA Form 337, "Major Repair and Alteration," dated October 22, 1992.

The October 22, 1992, Form 337 narrative stated, in part:

⁷Special mission refers to military components used in training exercises for ANG fighters.

Three hundred amps of DC power were made available for cabin use in running ECM sources while aircraft was operated in restricted category as defined under public use. Connection for this power category was made within the generator control panel at Station 473 using a pair of No. 0 awg wires.⁸ Reference Lear Wiring Manual page 34-31-00 [sic. 24-31-00] which covers this aircraft. The two No. 0 awg wires are routed to Station 459 where two 150 amp current limiters provide circuit protection. The two No. 0 wires exit their independent limiter and attach to main contactor relay XM-1 at Station 457. This relay is controlled within the cockpit by a switch available to the flight crew.

The narrative also stated, "No chafing or clearance problems exist with this installation," and "An electrical load analysis was made and determined that at 100 percent of rated draw, the air conditioner must be off."

The narrative page concluded with the sentence "Attached to this 337 is an approved 377 [sic] dated 02/27/89." The operator provided a copy of the 1989 Form 337 that was for a Phoenix Air operated Learjet 36A, registration N75TD. Following the narrative sentence beginning, "Safety is built into the system..." the referenced 1989 Form 337 stated, "(See Exhibit A, P862 and 836 [sic. 863] Pin A of each.)" "Exhibit A" (Learjet wiring manual page 24-31-00) shows that pins 862 and 863 are receptors for wires originating at generator bus terminals 6A and 5B. (Appendix C contains copies of the February 27, 1989, and October 22, 1992, Form 337s.)

The investigation found that in the actual mission equipment wiring of N521PA, the power wires were routed directly to the battery charging bus. (Figure 3a is a drawing of major components in the tailcone. Figure 3b shows the intended versus actual routing of the power wires in N521PA.)

Another FAA Form 337, dated October 22, 1992, was applicable to N521PA. It documented the installation of wing external attachment points for mounting special mission stores in accordance with Supplemental Type Certificate (STC) SA1670CE. A logbook entry, dated October 22, 1992, documented the removal of the CVR and FDR from N521PA. It also documented the installation of

⁸No. 0 awg wire is approximately 0.3249 inch in diameter.

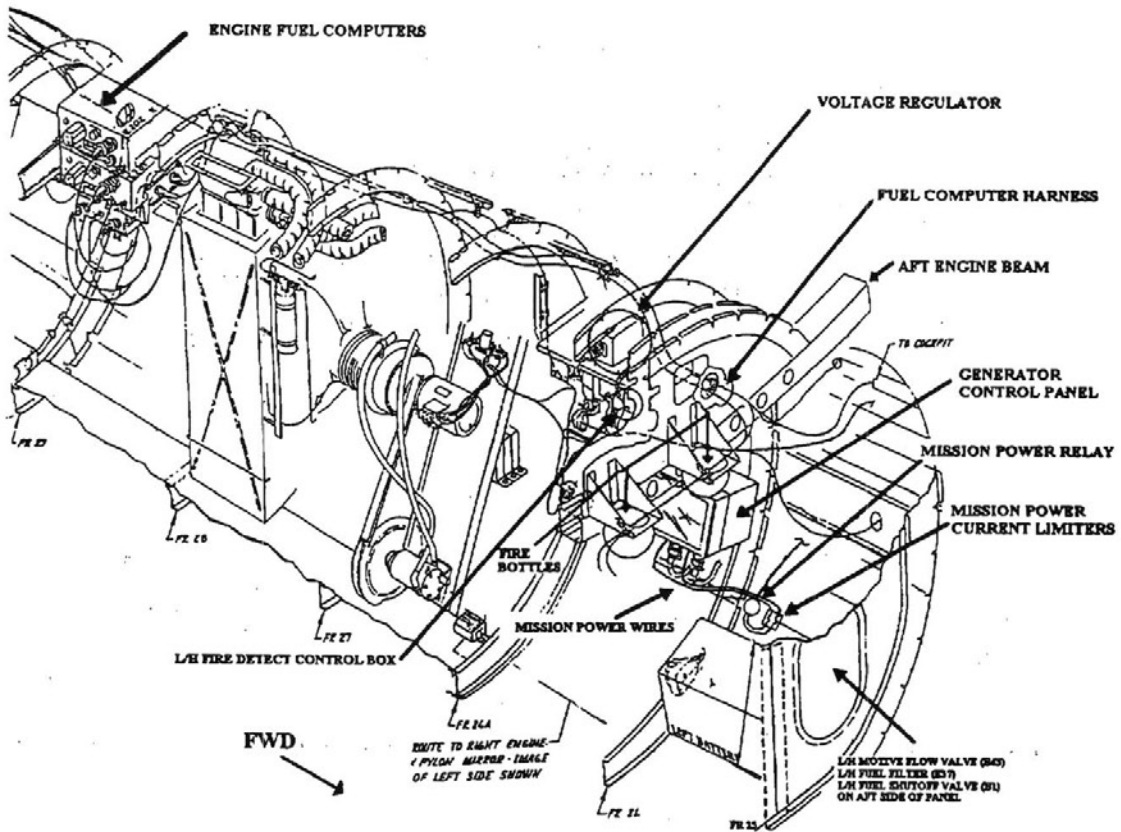

Figure 3a.--Components in tailcone.

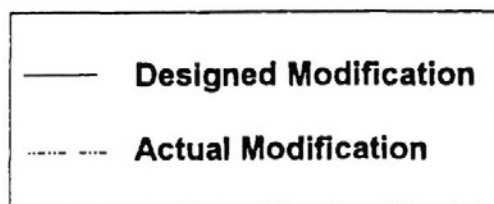
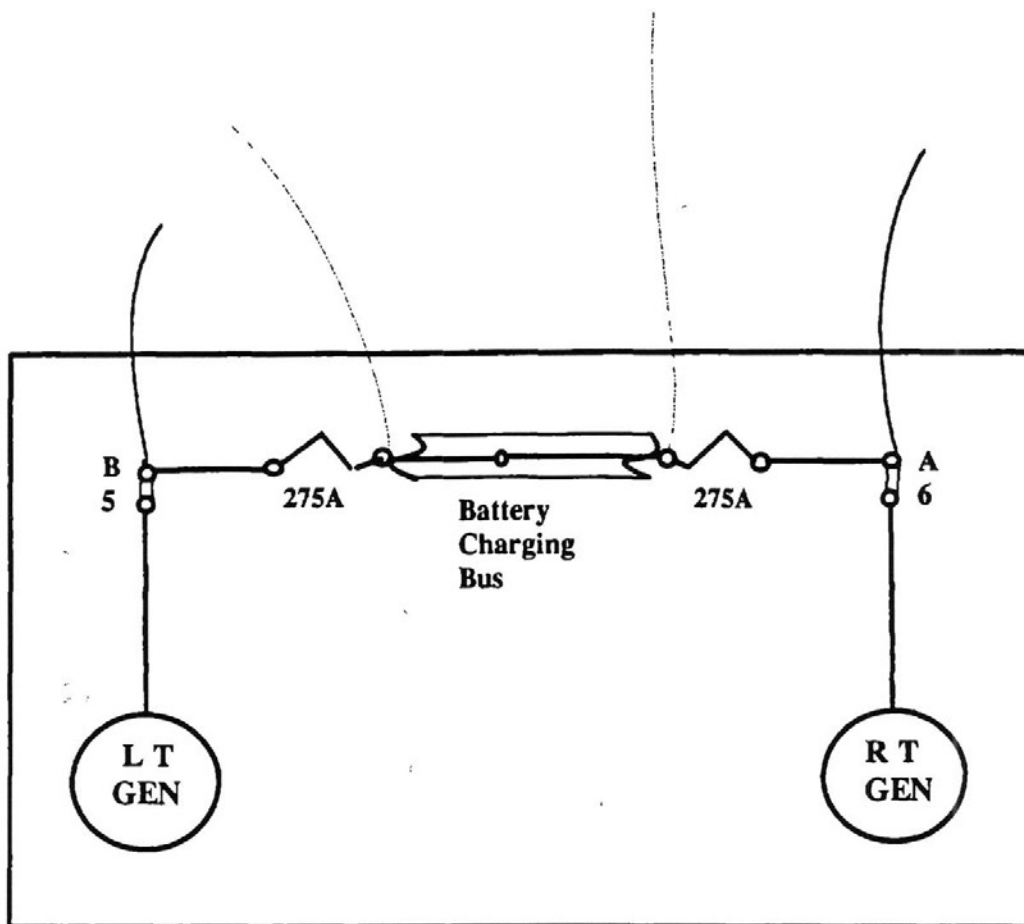

Figure 3b.--Mission power wiring.

a third very high frequency (VHF) receiver, a global positioning system satellite receiver, and an emergency locator transmitter.

1.6.6 Interviews With Maintenance Personnel

The mission power wiring alteration for N521PA was signed off on October 22, 1992, on the Form 337 by an A&P mechanic and a certified Inspection Authorization (IA) mechanic.⁹ Both individuals were interviewed after the accident.

The A&P mechanic described his experience in aircraft maintenance, which included obtaining an Associates Degree from the Pittsburgh School of Aeronautics in Aviation Maintenance in 1986. He worked briefly at Lockheed Corporation in a sheet metal shop before being employed by Phoenix Air in 1987. He obtained his A&P certificate while employed at Phoenix Air.

He stated that he could not specifically recall installing the wiring modification on N521PA. He said that he had performed the modification on several Learjets, but he could not recall the total number. Speaking in general terms, he noted nothing unusual about the physical conditions when the wiring work was performed. The airplanes were always in the hangar, at Cartersville, Georgia, during the modifications. He said that other than the "hell hole"¹⁰ being close quarters, there was nothing uncomfortable about the working environment. There was adequate lighting, and he felt no pressure to hurry his work.

He recalled using the Form 337 during the wiring modifications. He stated that nonroutine maintenance work cards were also used. Regarding guidance for the wiring alteration, he stated that he would use the airplane that he had just finished or another airplane on the ramp that had already been modified. He would stand in the "hell hole," look at the wiring modification, and copy it. He stated that this was standard operating procedure and that other mechanics did it the same way. When asked what he would do if there were not another aircraft to go by, he stated that he would refer to the Form 337. He stated that all of the mechanics in the shop were authorized to do the wiring installation, and that "everybody in the shop knew the procedure."

⁹An Inspection Authorization (IA) is obtained from the FAA after meeting prerequisites, which include the following: 1) The individual must have been an active A&P for the previous 2 years; and 2) must have completed a written examination and an oral evaluation. An IA is renewed yearly.

¹⁰Hell hole is a general term used by the manufacturer and operator to describe the maintenance entrance in the lower/aft fuselage.

The IA who signed off the Form 337 for the mission power wiring modifications on N521PA said that he was employed by Phoenix Air after leaving a small fixed base operation (FBO) of his own in July 1992. Prior to that he had been the Director of Maintenance for a corporate operator, Diamond G Aviation. He was employed there for approximately 3 years and received his IA certification while there, in January 1988. Prior to employment at Diamond G Aviation, he had various corporate aviation positions as a lead mechanic and flight technician. He had also worked at the National Aeronautics and Space Administration (NASA), Langley Research Center, Virginia for approximately 3 1/2 years as a maintenance technician. While employed there, he received his A&P certificate in about 1981. He had earlier experience during 4 years in the U.S. Navy as an aircraft mechanic. He stated that he had no experience on Learjets prior to being employed by Phoenix Air, and he took no Learjet-specific training courses since then. Specific aircraft maintenance courses that he had attended included the Gulfstream Commander and G-1.

The IA had been employed by Phoenix Air for about 3 months at the time of the initiation of the mission power wiring modification on the Learjets. He recalled nothing unusual regarding N521PA, just that it was a normal performing aircraft. He said that the modifications to the airplanes were always performed in the hangar, that the working conditions were comfortable, and "everybody worked well together." He stated that he signed off the IA inspection block on the Form 337 for this modification for the majority of the airplanes, but that one other IA who was no longer employed by Phoenix Air had signed off a few of the alterations. He stated that any mechanic in the shop was authorized to install the special mission wiring, and that he inspected other mechanics' work periodically. When asked what he used as a reference when he signed off the Form 337 for the wiring modifications, he stated that he would look at the wiring on a previously modified aircraft and compare the hookups, and reference the Form 337 for the previously modified aircraft. He also stated that nonroutine work cards were completed for the wiring modifications. When asked about his past experience with wiring and electronics, he indicated that he had worked with aircraft wiring throughout his career, particularly while employed by Diamond G Aviation and in general aviation.

The Phoenix Air Director of Maintenance was questioned about his knowledge of the modification procedures. He stated that 3 of the 18 mission-powered Learjets were purchased from another operator and were correctly wired. Prior to that purchase, the mission power wiring changes were begun on the 15 other Learjets. He stated that he found after the accident that a mechanic, who

asked where to install the wires was misdirected in the confines of the "hell hole." Another mechanic said, "put it there," and the mechanic working on that airplane thought that he was being pointed towards the battery bus, rather than properly towards the terminals for the generator bus. (The investigation found that the subject wires had been attached to terminals on the battery charging bus.) The Director of Maintenance stated that after the first airplane was miswired, the incorrect wiring alteration was copied on 14 subsequent Learjets and that a drawing was not referenced.

1.6.7 Maintenance Actions Subsequent to the Accident

On December 20, 1994, 6 days after the accident, the Phoenix Air Director of Maintenance issued an "Immediate Airworthiness Action" to Phoenix Air's seven maintenance sites to immediately stop flying the remaining 17 mission-equipped Learjets until the wiring was inspected for chafing, then "disconnect the special mission power wire from the generator control panel to the current limiter and remove this entire section of wire." On December 23, 1994, Learjet sent a letter to its operators, worldwide, stating that, "It is strongly recommended that [an inspection] take place prior to the next flight."

In January 1995, a new Form 337 was required by the Department of Defense to be prepared along with detailed drawings of the subject wiring modifications as part of its determination on whether to reinstate the mission. Phoenix Air provided the revised FAA Form 337, dated January 11, 1995. The January 1995, Form 337 stated, in part, "Connections for this power were made at the points on the Generator control panel where B-5 [was] for [the] left generator and A-6 for the right generator. The wires then went to a pair of current limiters mounted at Station 473.0 where the two 150 amp current limiters [were] installed to provide circuit protection."

On February 7, 1995, Phoenix Air issued "FAA Approved Airplane Flight Manual Supplement[s], Report PAS-1, for Learjet Model 35A," for each modified airplane. They stated, in part, that the "supplement must be attached to the approved Airplane Flight Manual when modified by the installation of the special Mission Power, installed in accordance with FAA Form 337, dated 1/11/95." Included in the supplements were emergency procedures for current limiter, inverter, or single generator failure, and procedures for the "installation and removal of special mission inverter systems."

Subsequent to a review that included the 1995 documents, the Department of Defense reinstated the mission with Learjets provided by Phoenix Air.

1.7 Meteorological Information

The accident occurred in visual meteorological conditions (VMC). The nearest weather observation to the time of the accident for FAT was made at 1150, approximately 3 minutes after impact. It was:

Clouds 6,000 scattered, estimated 10,000 broken, 20,000 overcast. Visibility 20 miles in light rain showers. Temperature 48 [Fahrenheit - F], dewpoint 39. Winds from 120 degrees at 9 knots. Altimeter 30.16 inches of mercury. Remarks: Rain began at 42 minutes past the hour.

KILO was the current ATIS for FAT. It read:

Clouds 11,000 [feet] scattered, estimated 20,000 overcast, 25 miles visibility. Temperature 46, dewpoint 39. Winds from 110 degrees at 7 knots. Altimeter setting 30.22. Remarks: Landing runway 11. Localizer back course runway 11 left or visual approaches in use.

At 1144:14, when the airplane was 5 miles from the airport, ATC reported the winds as 110 degrees at 6 knots. A flight instructor, who flew near the accident site, estimated the visibility at 20 miles.

The pilot of one of the two F-16s that had been operating with Dart 21 in the mission operating airspace said that they had been VMC in smooth air. On the return flight to FAT, between the mission operating airspace and the edge of the special use airspace, they experienced moderate clear air turbulence. Upon crossing back over the Sierra Nevada Range, they were in the vicinity of towering clouds up to 30,000 feet msl and were then in continuous instrument meteorological conditions (IMC) from over the mountains until reaching 9,000 feet west of the range in descent to FAT.

1.8 Aids to Navigation

The primary automation radar-tracking system used at Fresno was ARTS IIA, which was not a recorded system. Therefore, there were no data available to provide flightpath history. Recorded radar data of the accident flight were available from two sources: the National Track Analysis Program (NTAP) data from Oakland Air Route Traffic Control Center (ARTCC), and Radar Approach Control (RAPCON) data from NAS Lemoore, California.

NTAP data from Oakland ARTCC depicted beacon target and Mode-C altitude information for Dart 21 until 11:43:34, when it was at 7,500 feet msl.

RAPCON data from NAS Lemoore depicted beacon target and Mode-C altitude information for Dart 21 until 1145:44. The last recorded altitude was 1,000 feet msl. The data indicated that about the time of initial contact inbound, Dart 21 was on a northwesterly course at about 10,000 feet msl and at a ground speed of 290 knots. Corresponding to the flight's initial emergency call to ATC, the radar data show the flight making a left turn to a southwesterly course. This course corresponded to flying a right downwind leg for a landing on 29R. From 1143:57 to 1145:12, the airplane's ground speed varied between 290 and 310 knots. During this time, Dart 21 descended from 5,100 to 1,500 feet msl. About 1145:28, the airplane was at 1,400 feet msl and a right turn began which was consistent with a right base leg to 29R. About 1145:46, the airplane crossed the extended centerline about 2 nautical miles from the approach end of 29R.

1.9 Communications

There were no problems with the availability of communications.

1.10 Aerodrome Information

Fresno Air Terminal (FAT) is operated by the City of Fresno. The airport elevation is 333 feet msl. The ATC facility at FAT is operated by the FAA. It is a combined Level III Radar Approach Control and tower facility.

FAT is located at 36 degrees 47 minutes north latitude, and 119 degrees 43 minutes west longitude. At the time of the accident, FAT was served by parallel runways 11 Left (11L)/29R, and 11R/29L. Runway 11L/29R was 9,222 feet in length, with a width of 150 feet. Runway 11R/29L was 7,206 feet

long, with a width of 100 feet. The radar control facility for Fresno was located in the same building as the tower. The tower was located approximately midfield, south of 11R/29L.

At the time of the accident, there were three controllers and one supervisor in the tower cab. All four of them observed the inbound flight of Dart 21 after it came into view approaching from the northeast.

1.11 Flight Recorders

There was no cockpit voice recorder or flight data recorder installed, nor were they required in the public-use aircraft.

1.12 Wreckage and Impact Information

1.12.1 Airframe and Ground Damage

The airplane came to rest in a residential area of Fresno, about 2 miles southwest of FAT. The wreckage path was oriented on a track of 270 degrees on E. Olive Avenue over a distance of about 1,300 feet. The airplane was destroyed during the impact and postcrash fire. Several units in two apartment buildings along the wreckage path were destroyed by impact and subsequent fire.

The first impact evidence showed that the right wing tip/fuel tank of the airplane struck a lamp pole near the sidewalk on the northwest corner of E. Olive and N. Chestnut. The lamp pole was struck about 19 feet above the ground and a traffic light at the intersection was also knocked down. Immediately after the right wing impacted the lamp pole, the left wing, all three landing gear, and the fuselage of the airplane impacted on E. Olive. The left wing tip and its attached fuel tank impacted near the centerline of the avenue. Impact marks from the nose and main landing gear penetrated approximately 2 inches into the asphalt, heading in a westerly direction.

The main fuselage, as evidenced by ground and asphalt scars and a blackened fire trail, continued to travel along the sidewalk on the north side of E. Olive. The witnesses to the accident sequence stated that there was a continuous fireball after the initial impact with the street until parts visibly broke free after more than a block of travel. Immediately prior to the intersection at N. Recreation, the airplane began to veer across the sidewalk and impacted and moved two large

decorative boulders that were immediately north of the sidewalk, in front of an office building on the northeast corner of E. Olive and N. Recreation. The nose section of the airplane and related systems were found in the area of this intersection, continuing to the northwest corner of the intersection, and to the south side of the first Olivewood apartment building to the west of the intersection. The radome, equipment bay doors, radios, radar, nose strut and strut actuator, instrument panel, control column, control wheels, rudder pedal assembly, crew seats and fragmented windshields pieces were found in this area. The pilots' bodies were recovered on the south side of the apartment building.

The right wing and right engine came to rest, on fire, on E. Olive, approximately 100 feet east of the intersection with N. Sierra Vista and about 1,200 feet west of the initial impact marks. The right wing was fractured into several pieces. The inboard 10 feet of the wing came to rest near the center of E. Olive, immediately west of the right engine.

Disassembly of the right engine at the factory found no evidence of internal or external preimpact fire damage. The disassembly revealed that the engine was producing above flight idle power at impact. (See Fire, 1.14, for details of fire damage to the aft engine support beam.)

The ground fire was most severe along the north side of E. Olive, between N. Recreation and N. Sierra Vista. The remains of the left wing were combined with fuselage structure and found inverted in debris to the north side of E. Olive between the south-facing sides of the impacted apartment buildings. Most of the aluminum structure was melted, and the left wing was barely recognizable, except for the remaining steel components. Twelve vehicles, parked along the north curb of E. Olive, between N. Recreation and N. Sierra Vista, were ignited and destroyed by fire. Damage to structures along the south side of E. Olive was generally restricted to flash burns.

The empennage separated from the main fuselage as a unit and came to rest on the south side of E. Olive. It was not on fire. There was evidence of soot found around the lightning holes in the structure between the aft fuselage and the forward spar of the vertical stabilizer.

The left engine came to rest in the living room of one of the first floor apartments in the second building to the west of the intersection. There was no evidence of fire damage to the engine or the inside of the room in the apartment.

The engine had impacted a tree, approximately 30 feet southeast of its final resting position, and a portion of the nose spinner was imbedded in the tree trunk. Disassembly of the engine at the factory found that the engine was in a windmilling condition (not under power) at the time of impact. There was no evidence of internal or external fire damage.

Portions of the burned wreckage from immediately aft of the cockpit to the aft pressure bulkhead, and midfuselage structure and systems, including the fuel cell, the motive flow valves for fuel and oil, and avionics-related components were found mostly fire damaged between E. Olive and the south faces of the impacted apartment buildings. The tailcone access door to the electronics bay or "hell hole" was found intact with little fire damage.

Portions of the burned wreckage from immediately aft of the cockpit to the aft pressure bulkhead were found farther to the west of the intersection with N. Recreation in the area of the sidewalk on the north side of E. Olive between the south faces of the impacted apartment buildings.

Midfuselage structure and systems were found with extreme fire damage, including the fuel cell, the motive flow valves for fuel and oil, and avionics-related components near the burning apartment buildings. The tailcone access door to the electronics bay (hell hole) was found intact. It had less fire damage than the associated fuselage components.

1.12.2 Cockpit

The cockpit was extensively damaged by impact forces. Most of the cockpit wreckage was recovered, but not all of the cockpit indicators were recovered.

Recovered cockpit engine instruments were examined at the facility of the subsystem manufacturer. None of the engine indicators could be functionally tested due to impact damage. All power warning flags were broken loose and all instrument indications were found to be unreliable.

The manufacturer demonstrated with similar instruments that a tachometer indicating revolutions per minute (RPM), as a percentage, would go to zero with a loss of the data signal and would spool down in about 2.5 seconds. If there were a loss of bus power, the engine RPM would stay at the last indicated

reading. Conversely, the engine temperature indications would remain in place with a loss of the data signal or a loss of bus power. According to the manufacturer, if a thermocouple harness were to become shorted, then the engine temperature instrument would indicate the local temperature at the location of the short. Both engine temperature gauges (turbine inlet temperature (TIT)) were found in the wreckage. The motor-drive crown gears were found disengaged from impact damage, and the significant digits on the indicator drums, as well as the pointers, were free to rotate.

The left engine fire detection T-handle was recovered from the cockpit wreckage in the stowed or normal position. There was no evidence of hot stretching (elongation) of the bulb filaments in the T-handle that would occur when a hot filament receives an impact load. The hydraulic and fuel valves for the left engine were each found in the open or normal positions. By design, pulling a T-handle would actuate the respective engine's fuel and hydraulic valves to the closed position. The right T-handle was not found. The right engine fuel shutoff valve was found partially melted in burned wreckage.

The throttle quadrant was found separated from the cockpit structure. With cables still attached, it lay on the grass in front of an apartment. A portion of a tree trunk or branch was wedged between the two levers. Disassembly of the unit revealed evidence that both levers were full forward at impact.

The guarded spoilers deployment switch (trigger guard) was attached to the base of the throttle quadrant. The switch was found in the spoilers-deployed position. The switch was located on the lower right side of the power lever quadrant. The electrically powered actuator for elevator trim was found about 1 degree from a full nose-down trim position. According to Learjet, the actuator would remain in its impact position and would provide a reliable indication of elevator trim at impact.

1.12.3 Airplane Systems

The two spherical stainless steel Halon fire bottles were recovered. One was found totally void of its aluminum plumbing and its initiation cartridges. The second bottle was determined to be the right bottle based on the remaining plumbing and its two attached cartridges. Examination of the cartridges revealed that the cartridge that opens the plumbing from the right fire bottle to the left engine

had been electrically fired.¹¹ Manufacturer data showed that the cartridges could autofire at 450, plus or minus 25 degrees F. The safety release for the right fire bottle was found intact. The safety release should activate at temperatures from 215 to 226 degrees F.

The fire detection control boxes for the left and right engines are located in the left and right side of the aft fuselage, respectively. The left fire control box is mounted above the generator control panel. The control boxes were found separated from the fuselage, lying in an area of substantial postimpact fire. All airplane fuel tanks were found in the wreckage, ruptured and severely burned. No fuel could be found in the airframe fuel system. The hydraulic system was virtually destroyed, and no useful information could be gained. (Section 1.14, Fire, contains a description of electrical power supply system damage.)

1.13 Medical and Pathological Information

Autopsies were performed on both pilots by the local coroner's office. Toxicological specimens were taken, secured, and transported to the Toxicology and Accident Research Laboratory at the FAA's Mike Monroney Aeronautical Center in Oklahoma City. No carboxyhemoglobin, cyanide, or ethanol were detected in the fluid samples from either pilot.

The samples were tested for amphetamines, opiates, marijuana, cocaine, phencyclidine, benzodiazepines, barbiturates, antidepressants,

¹¹The Flight Safety International LEARJET 30 SERIES, Models 35/36 Pilot Training Manual, revised April 1988, describes the "FIRE OR ENG[ine] FIRE T-HANDLES AND ARMED LIGHTS" systems, as follows

"When a FIRE PULL or ENG FIRE PULL light begins to flash, it indicates a fire or overheat condition in the respective engine cowling. Following AFM [airplane flight manual] procedures, the pilot should first place the affected engine thrust lever to CUT-OFF and then pull the corresponding T-handle. Pulling out on the T-handle closes the main fuel, hydraulic, and bleed-air shutoff valves for that engine. DC essential bus electrical power to close these valves is provided through the L and R FW SOV (firewall shutoff valve) circuit breakers on the pilot's and copilot's circuit breaker panels, respectively

There are two ARMED lights above each T-handle. Pulling either T-handle arms the fire extinguisher system, which is indicated by illumination of the two ARMED lights above the handle which was pulled. Depressing an illuminated ARMED light momentarily supplies DC power to an explosive cartridge which discharges the contents of one fire extinguisher bottle and allows it to flow into the affected engine nacelle. When the ARMED light is depressed, a holding relay is also engaged which extinguishes the ARMED light, indicating that the associated bottle has been discharged. Either ARMED light may be depressed to extinguish the fire. Should one container control the fire, the other container is still available to either engine."

antihistamines, meprobamate, methaqualone, and nicotine. The samples for both pilots were negative for a wide range of licit and illicit drugs.

1.14 Fire

There was evidence of in-flight fire damage in the aft fuselage area of the electronics bay (hell hole). Soot deposits were found around lightening holes in the vertical stabilizer. These holes were at the interface between the aft tailcone and the interior of the forward portion of the vertical stabilizer. A piece of fuselage skin from the left side of the fuselage, starting at approximately frame 26 and extending aft to about frame 28 under the left engine pylon, was recovered from the scene and examined. The inside surface of this fuselage section was heavily sooted with some actual flame damage. A small hole in the fuselage appeared to have pitting and "broom straw"¹² on the forward ends of the stringers. Sooting was not present where the stringers had been pulled away from the fuselage skin.

Neither engine showed evidence of in-flight fire. The aft engine support beam had fractured about 18 inches inboard from the right engine. The fractured end of the beam was crushed and heat damaged from the fracture surface rearward about 3 inches. The crushing damage was consistent with deformation that occurred while the material was hot.

The aft support beam had fractured about 9 inches inboard from the left engine. The fracture location was just outside of the fuselage attachment. The fracture surface showed heat damage.

The total design length of the aft engine support beam is 58.962 inches and is located at frame 25A. About 32 inches of the beam from inside the fuselage were not found in the wreckage. The remains of the beam were examined at the manufacturer and at the Safety Board's Materials Laboratory. The material had experienced high temperatures in the area where it passed through the aft fuselage between the engines. The analysis found that portions of the beam that had traversed through the aft fuselage had been near the melting point of aluminum (at about 1,200 degrees F).

¹²Broom straw" refers to separation and fragmenting of the material along partially melted material at the grain boundaries, which produce a straw-like appearance

Portions of the wires, identified as part of the electrical power source for the special mission package, were size No. 0 awg and were found on E. Olive, near the wheel of an unburned vehicle. The wires had evidence of high heating prior to impact, including areas fused together for about 2 inches in length, and individual strands of the wires had a beaded appearance. (See figure 4.) Current limiters (fuses) were found attached to the nonwelded ends of one of the two sets of wires. In subsequent testing, the current limiters were found to provide electrical continuity (in the closed position).

The current limiter panel, including the battery bus and generator control panel, was found in the wreckage, exhibiting extensive fire damage. The 275-amp generator current limiters (fuses) for protection of the right and left generators were found closed. A third current limiter was found still in place on the current limiter panel which had been part of the air conditioning system power supply. It also subsequently tested positively for continuity (was found closed).

Most of one battery was located in the wreckage; the other was virtually destroyed. The preimpact location of the batteries, one on the right and one on the left in the electronics bay, was not determined. Two of the four battery hold-down bolts were found bent, one was slightly bent, and the other one was straight.

Sections of the fuel computer harnesses were found still attached to both engines. Each harness consists of eight double leads that feed signal information to the fuel management computer. Each of the double leads are shielded with a metal mesh. The eight leads are wrapped together and covered with a double metal shield and finally wrapped with fiberglass. The portion of the left engine harness attached to the engine was about 32 inches long from the point at which it passes through the fuselage skin to the point at which it was torn apart during the accident sequence. The fiberglass wrap was still present where the harness feeds through the fuselage from the engine nacelle; however, the binder was burned out of the fiberglass. The fiberglass wrap was not present on the remaining part of the harness. From about 10 inches to the broken end of this harness, the harness was necked down. The harness was cut at about 18 inches, in the center of the necked area, and metal braiding was removed. It was noted that all the electrical insulation had been destroyed so that all the wires in the bundle were no longer insulated from the shield or each other. The electrical insulation was reported by the engine manufacturer as Teflon. Teflon has a thermal decomposition

temperature of about 600° Celsius, which is above the melting point of aluminum alloys.

The computer harness for the right engine measured 27 inches from inside the fuselage skin to the torn termination. Examination of this harness showed that the electrical insulation had also been destroyed.

The engine fuel computer harnesses enter the fuselage from the respective engines just forward of the aft support beam for the engines. These harnesses come together forward of the left fire bottle and run aft through a lightening hole in the aft engine beam. The two harnesses are approximately 16 inches above the welded special mission power wires. The harness continues aft along the left side of the fuselage to the fuel computers located between frames 29 and 30 on the left side of the fuselage. The right engine fuel computer harness runs across the fuselage on the forward side of the aft engine beam.

The two low pressure fuel filter/shut-off valve assemblies and the two high pressure motive flow valves (a set of each for each engine) were located in the wreckage and examined. These fuel system components are mounted on bulkhead plating at frame 25. This plating forms the support for the aft fuel cell bladder. The motive flow valves are mounted symmetrically about the horizontal center axis of the fuselage and symmetrically about the vertical centerline of the fuselage. The low pressure fuel filter/shutoff valves are mounted below the respective motive flow valves. Both of the filter/valve assemblies were heavily damaged by fire. Both filter containers were missing from the filter clamp with molten aluminum under the clamp. Neither filter cartridge was located. The left shutoff valve was separated from the filter as a result of fire damage with extensive molten aluminum attached to the valve. The right shutoff valve was still attached to the top of the filter.

The right and left motive flow valves were also recovered and examined. The right and left motive flow valves are pressurized to about 300 pounds per square inch (psi) by the right and left engines, respectively. Both motive flow valves were damaged by fire, and some impact force damages were noted. The left valve was more fire damaged than the right valve. The 1/2-inch-diameter inlet fitting to the left motive flow valve was missing. Examination of the threads in the inlet fitting receptacle showed some aluminum splatters. The threads in the motive flow valve were intact with no damage.

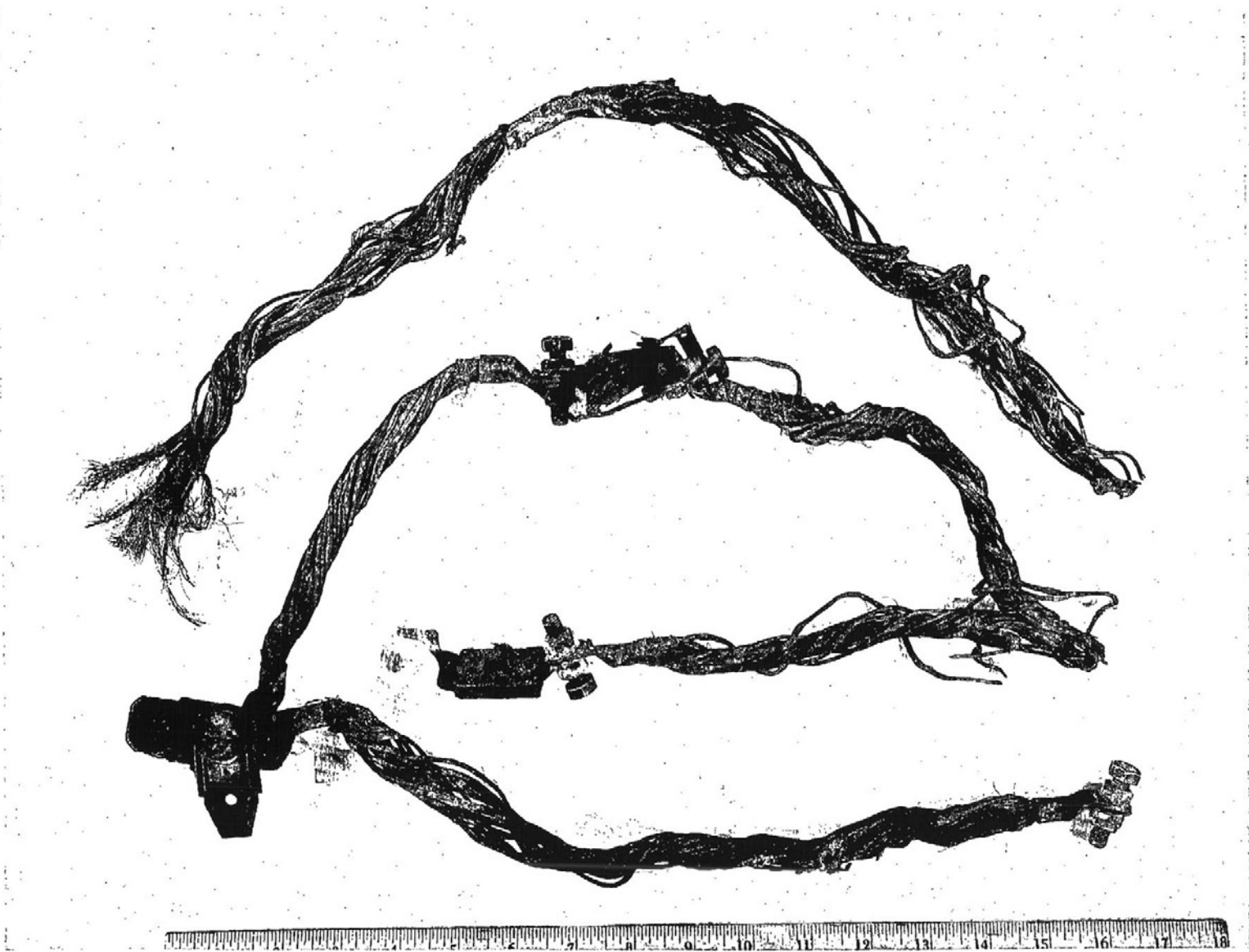

Figure 4.--View of cables as received for examination.

Four steel braided synthetic (rubber tubing inside a steel braid) 1/4-inch-diameter hoses are routed in the electronics bay through the aft engine beam for cabin air conditioning. A fifth, 1/4-inch-diameter aluminum tube is routed forward that provides pressurization for the alcohol defogging/deicing of the windshield. About frame 25, the aluminum alcohol pressurization tubing transits into a 1/4-inch-diameter rubber hose that is encased in a steel braid. At frame 25, the alcohol pressurization hose and the four cabin environment control hoses are carried forward in an aluminum conduit that is located along the left side of the fuselage. All five hoses are connected to a common plate mounted on the aft pressure bulkhead at frame 22.

The attachment plate with portions of four steel braided hoses attached to it was retrieved from the wreckage and examined. Two melted holes were found in one of the steel braids covering one of these hoses. A similar hole was found in a second braid at approximately the same length from the attachment plate. Measurements of the distance from the attachment plate to the holes in the braids show the holes to be in the general location of the aft engine beam. The aluminum alcohol tank pressurization tubing was not located. Pressure for the alcohol system is provided by high temperature engine bleed air.

The alcohol pressurization system was the subject of a Learjet service bulletin (SB) dated December 18, 1992. The SB followed an AMK 91-1 (Aircraft Maintenance Kit) that was issued in February 14, 1992. The SB recommended that:

1. The alcohol tank pressurization plumbing be inspected for leaks not later than the next 10 flight hours after receipt of SB.
2. Inspect engine pylon drain lines not later than the next 10 flight hours after receipt of SB.
3. Install orifice fitting in alcohol tank pressurization plumbing not later than the next 25 flight hours after receipt of SB.

According to the SB, the inspection of the alcohol pressurization plumbing is not required on aircraft having complied with "AMK 91-1, Replacement of Alcohol Tank Pressurization Hose."

According to Learjet, the kit was issued to replace the deteriorating rubber pressurization hose with an aluminum tube. There had been several reported failures

(leaks) in the alcohol pressurization hose between frame 22 and frame 25 in field aircraft, which resulted in the SB. The leaks in the alcohol pressurization hose resulted in damage to the temperature control system hoses that caused a failure of the automatic environmental control system in the cabin. The kit provides a replacement of the hose between frames 22 and 25 and the installation of an orifice to limit the air flow rate into the enclosed spaces, should a leak occur in the line. The temperature of the air flowing in this line is dependent on the flow rate. Studies by Learjet indicate the air temperature supplied by the engine bleed air can be as high as 600 F. Again, this temperature will depend largely on the size of the leak in the alcohol pressurization system.

The accident airplane had not complied with AMK 91-1. Further, it could not be determined if the automatic cabin temperature control system was functioning properly (the first sign that the alcohol pressurization system was leaking onto the environmental control hoses).

1.15 Survival Aspects

The impact was not survivable for the two pilots.

The Fresno Police Department received the first 911 call at 1147:35, or about 1 minute after the crash. The first police unit was dispatched at 1147:59. Within the next 3 minutes, three additional police officers and a sergeant arrived on scene.

The Fresno Fire Department issued a first alarm 2 minutes following the crash. Four engines, two trucks, and a battalion vehicle were dispatched. The first fire engine, stationed about 2 blocks from the scene, arrived 3 minutes following impact.

A police and fire command post was established at the intersection of E. Olive and N. Sierra Vista. A foam and water truck arrived from the crash and rescue unit at FAT about 6 minutes after impact. Within 7 minutes following the crash, the first emergency medical service (EMS) units from Fresno County had arrived, and a rescue staging area was established at the intersection of E. Olive and N. Chestnut. Public rescue services were assisted by private ambulances. The injured were sent to various area hospitals.

A second fire alarm was issued 9 minutes after impact, and four fire engines and a truck were dispatched. At 1204, a third alarm was issued, and a

strike team was dispatched from Fresno County, on contract with the California Department of Forestry.

The first fire department captain on the scene was relieved by a second captain, who was subsequently relieved by the Chief of the Fresno Fire Department. A captain and lieutenant were the police department incident commanders.

The police department secured the scene, consisting primarily of E. Olive and adjacent buildings and houses, from N. Chestnut to N. Sierra Vista, as well as portions of the intersecting avenues. The police and fire departments provided equipment to assist the investigators. At 1800, on Sunday, December 18, 1995, after the Safety Board completed its requirements for a secure site, E. Olive Avenue and associated intersections were reopened.

1.16 Tests and Research

1.16.1 Flight Simulations

Under the direction of the Safety Board, 12 flights were accomplished in a Learjet 35 simulator, using accident investigation evidence that included accident flight track and profile information that was obtained from recorded radar data at NAS Lemoore. Two significant variables that were used in some of the simulated flights were: 1) the possibility that the spoilers were extended during the descent and that they remained extended until impact, and 2) that elevator trim was at nearly full nose down position throughout the emergency.

In the simulator flights, a variety of emergencies were used, including single and no engine power, deployed spoilers and/or full nose down trim. Although control forces were heavy (with an estimated 60 to 70 pounds of back pressure on yoke required at some speeds to overcome full nose down trim), the airplane was controllable. Turns could be made with sufficient back pressure. There was sufficient speed for the flight to land on the approach end of 29R, from the time of the call from Fresno APC that the field was at 12 o'clock and 4 miles, with no engine power, spoilers deployed, and full nose-down trim. It should be noted that the flight simulator is used primarily for pilot training, proficiency, and flight checks, and is not designed to be an engineering simulator to test airplane capabilities, especially near the edge of the operational envelope.

1.17 Organizational and Management Information

1.17.1 General

Phoenix Air was contracted by the USAF to provide training flight services for ANG aircrews. The contract was effective on May 18, 1992, and was administered by the 4400th Contracting Squadron, Langley Air Force Base, Virginia.

The contract included a Performance Work Statement (PWS), which outlined the responsibilities of the contractor (Phoenix Air). The PWS required that contractor flightcrews possess FAA commercial pilot certificates with instrument privileges. It also stated that contractor flightcrews would be certified in accordance with the applicable FAA directives for their respective duties and would operate aircraft in accordance with FAA, USAF, ANG, host unit regulations, and host nation requirements (non-US overseas locations). Further, it specified that flightcrews would operate aircraft within FAA flight time and crew duty time limitations. The contract did not specify maintenance oversight by the DOD.

1.17.2 Maintenance

The operator maintained the airplane under a USAF Contracted Training Flight Services (CTFS) Program. The contract's performance work statement defined the maintenance program standards and specified, "All aircraft used for performance under this contract shall be certified, operated, and maintained in accordance with applicable Federal Aviation Administration (FAA) regulations (FAR) and directives as well as factory recommended maintenance schedules and procedures." The contract further stated, "Contractor aircraft may be dual certified and operate under both FAR Part 135 and FAR Part 91 or under the 'Public Use' sections of the FARs, subject to the limitations imposed by the restricted Category Certificate as long as the restrictions do not preclude the aircraft from performing the mission as scheduled."

The contract further stated that maintenance aspects of the program were to be supervised by a flight line mechanic having an FAA "Airframe and Propulsion System (A&P) License" (Airframe and Powerplant Certificate).

At the time of the accident, Phoenix Air operated a fleet of 22 Learjets, maintained at 7 locations. Special mission power wiring and equipment were

installed in 18 of the Learjets. All of these airplanes were operated as public-use aircraft. Four of the airplanes, not including N521PA, were also used to perform on-demand air taxi operations under 14 CFR 135. When any of the four dual-use airplanes were used in air taxi operations, the mission equipment was removed from the cabin but the mission power wiring remained in place, and usually the operator removed one or more seatbelts so that less than 6 seats were usable in the cabin and CVRs were not installed.¹³ All mission power equipped Learjets were maintained by Phoenix Air using an FAA-approved Learjet inspection program. Phoenix Air elected to maintain the fleet of Learjets utilizing the same program to standardize maintenance inspections and records.

All aircraft maintenance records were maintained at Phoenix Air corporate headquarters, Cartersville, Georgia, as well as a maintenance technical library. Pertinent maintenance publications were maintained at remote locations.

The accident airplane and two other Learjets were based and maintained at LMT by two Phoenix Air A&P mechanics. The three airplanes were parked on the ANG ramp for security reasons and maintenance functions were performed in space provided by the Oregon ANG. Four pilots were based at LMT, and Phoenix Air appointed one of the pilots as a supervisor of the LMT operation. The mechanics reported to the Director of Maintenance based at corporate headquarters regarding the airworthiness of the aircraft.

In order to ensure continuous airworthiness of the aircraft, the Director of Maintenance coordinated the scheduling of all aspects of maintenance with the mechanics. He accomplished the coordination by telephone, facsimile machine, and overnight mail services. When the situation dictated, he adjusted the work force or the work location by arranging for the transportation of additional maintenance personnel to a remote location or by ferrying aircraft to the corporate headquarters' maintenance base.

Once a scheduled maintenance activity had been accomplished, the mechanics would transmit a copy of the maintenance record via facsimile machine to the Director of Maintenance. The original record was then to be sent to corporate headquarters and archived with the aircraft maintenance records.

¹³14 CFR 135 151(a) states, "After October 11, 1991, no person may operate a multiengine, turbine-powered airplane or rotorcraft having a passenger seating configuration of six or more and for which two pilots are required by certification or operating rules unless it is equipped with an approved cockpit voice recorder "

1.17.3 DOD Safety-Survey

On March 21 and 22, 1994, the Chief of the (DOD) Air Carrier Survey and Analysis Office, Headquarters, Air Mobility Command (AMC/XOB) and staff conducted a "biennial survey" of Phoenix Air at the company's headquarters. The purpose of the survey was to assess the operator's ability to continue providing safe and reliable airlift support to the DOD under the provisions of a Military Traffic Command tender of service for passenger and cargo operations. The company was rated "Average" in all areas that were evaluated, except for "Training" and "Operational Control," which received evaluations of "Above Average," and "Quality Assurance," which received an evaluation of "Below Average." The evaluator graded the operator "Average" in the following maintenance-related areas: maintenance inspection activity, maintenance training, maintenance control/planning, aircraft maintenance program, and aircraft maintenance records.

The survey stated that Phoenix Air met all DOD commercial air quality and safety requirements, with an exception in the area of maintenance. It was noted that the Quality Assurance Program had an incomplete vendor audit program. Also, "Continuing analysis and surveillance (CAS) is informal. Accomplished by monitoring the daily maintenance activity and aircraft status." In response, Phoenix Air developed a satisfactory monitoring program of vendors and improved documentation of records regarding vendors to ensure that its airplanes were maintained with approved parts.

1.18 Additional Information

1.18.1 Crew Resource Management Training

At the time of the accident, Crew Resource Management (CRM) was taught as a normal course of instruction for all Phoenix Air aircrews flying under public-use provisions.

Annually, the aircrews would "stand down" and meet in Fargo, North Dakota, for about 3 days of training. This training was mandatory for all public-use aircrews. The training consisted of classroom instruction on special mission and safety matters, including a classroom course in CRM. The Phoenix Air chief pilot conducted the course, which included training on situational awareness, error chains, communications skills, decision making, and handling stress. The sessions

ended with question, answer, and discussion periods. Phoenix Air also conducted this training, subsequent to commencement of the contract with the USAF/ANG, in September 1992 and October 1993.

In addition to the annual company training, the public-use aircrews received CRM training during annual recurrent training periods at FSI. According to the Center Manager at FSI's Tucson, Arizona, facility, CRM was taught in two phases: 1) in the classroom, and 2) during simulator flights.

In the academic phase (classroom) of training, CRM was taught as a particular aircraft system was covered. The instructors introduced representative scenarios in the coverage of both normal and emergency procedures. The instructors created situations in which the students participated in class, discussing workload, task sharing, and other CRM issues. The CRM portion was not specifically written into the classroom training syllabus. The training was blended in the classroom situations when applicable.

The in-simulator phase of CRM training at FSI was performance based rather than academically based. A grade was given for CRM performance on each simulator training mission. The pilots were evaluated on how they managed normal and emergency situations, and they were critiqued after each flight. On some of the simulator flights, the pilots' actions were recorded on videotape, and they subsequently viewed the tape with instructors.

1.19 New Investigative Techniques

No new investigative techniques were used.

2. ANALYSIS

2.1 General

Weather was not a factor in this accident.

Air traffic control services were provided in accordance with established criteria and were not a factor in the cause of this accident.

The flightcrew was properly trained and qualified for the flight, and they had received sufficient rest before the accident flight. Because the operation for the ANG was considered public use, the pilots did not have to meet all of the requirements specified in the Federal Aviation Regulations (FARs). However, they were qualified to fly air taxi operations for the operator. Also, both pilots had recently completed CRM training during both standdown company training (in-classroom) and at FSI (in-classroom and flight simulator CRM training). There is no evidence that a lack of CRM contributed to the accident.

The evidence in this accident indicates that the pilots encountered an in-flight emergency involving fire in the aft fuselage. The evidence strongly suggests that the flightcrew was first alerted to a problem by an engine fire warning light, which was probably on the left side because they later discussed "engine fire on the right side too, it shows." Adjacent to the mission power wires was the left engine fire warning control box. The input/output wiring harness for the fuel control computer for both engines was also routed just above this area. The fire warning circuits for the left engine above the ignition area probably became involved early in the fire. This would have triggered the left engine fire warning system and the subsequent shutdown of the engine by the pilots. Examination of the engine revealed no in-flight fire damage and no indication of power at impact. Evidence indicated that the right engine fire bottle was electrically fired to the left engine, which also supports the scenario.

The left engine fuel and hydraulic valves were found in the open or normal operating positions. Laboratory examination of the bulb filaments found that the left engine T-handle, which had been recovered in the stowed position, showed no evidence of stretching. These are not the positions to be expected for an engine that was shut down because of a fire indication. Based on the ATC transcript, the flightcrew did not talk about any attempts at engine restart(s). About 1 minute before impact, after the captain said, "We got an engine fire on the right side too, it

shows," the first officer asked the captain, "do we have any power?" The captain stated, "I'm not getting any response, man." It is possible that the first officer began the restart sequence on the secured left engine. Disassembly found that both power levers were in the full-forward position at impact, and an attempted restart on the left engine would have initially required that the left engine fire T-handle be pushed into the normal position. The result would have been to reopen the left engine fuel and hydraulic valves.

The flightcrew may also have received a fire warning later in the flight as the fire continued to cause damage in the aft fuselage area. Their comment about "fire on the right side too, it shows" supports this possibility. There was no reasonable means for the flightcrew to observe fire in the aft fuselage from the cockpit. Consequently, their remarks about the location of the fire probably came from the cockpit engine T-handle fire warnings. Determination of the at-impact location of pointers and digits would have been valuable in determining what engine instrument information, if any, was available to the flightcrew immediately before impact, as well as whether or how electrical shorting and a fire in the aft fuselage affected cockpit instrumentation. However, laboratory examinations were not able to gain useful information from the instruments.

Although the airplane appeared to be in a controlled, gradual, high-speed descent until just before it crashed, the tower recording of the pilots' voices indicated that they were having difficulties controlling the airplane during the last portion of the flight, as well as in diagnosing mounting problems with the airplane. The airplane crossed the extended centerline of the runway, did not turn to final approach, and subsequently crashed in a nose-low left-wing-down attitude. It crashed nearly aligned with a wide residential avenue. Consequently, the Safety Board's analysis of this accident focused on the reasons for the in-flight fire and the reasons that the pilots were unable to perform a successful emergency landing. The analysis also examined the oversight of the maintenance and inspection of the airplane by the operator.

2.2 The Fire

The evidence found in the wreckage showed that the electrical power cables for the special mission equipment had not been installed in accordance with specifications. The improper installation left portions of the wires unprotected by current limiters. The two large-diameter DC power wires that were retrieved from the wreckage showed evidence of arcing and they were "welded" together in the area

unprotected by the current limiters. This evidence indicates shorting and unlimited current flow for an extended period of time while the airplane was airborne.

The investigation revealed that the proper installation specified that the special mission wires were to be attached to fittings in the generator control panel, where they would have been protected from overload during shorts by current limiters. Instead, the wires had been routed directly from the battery charging bus to 150 amp limiters before being routed to the control relay. Segments of the wires were unprotected by current limiters for about 18 inches, and they were found fused together between the battery bus and the current limiters. As a result of the wiring arrangement, large amounts of current could travel to the ground.

Fire damage to the wire insulation precluded a determination of the reasons for the shorting of the wires; however, one of these wires may have been frayed, and a short to ground (probably an airplane frame) occurred. Nevertheless, the evidence is conclusive that while the airplane was airborne, a severe short occurred on the left side of the aft fuselage in the electronics bay. Without the protection of the current limiters, the short was not interrupted.

The evidence suggests that the arcing probably ignited wiring insulation and other combustible materials on the left side of the electronics bay. This caused damage to adjacent components. However, melting of the aft engine beam, the loss of Teflon electrical insulation on the engine fuel computer harness, and holes burned in the steel shield on the cabin conditioning hose required an intense fire directed at these items that was farther to the left side of the airplane. A diffuse fire limited to the electrical insulation and other solid combustibles in this area is unlikely to cause the type of fire damage noted. A "torch-like" flame from a pressurized fuel leak would be consistent with the fire damage noted on these items. The fact that these heavily fire-damaged components were in the same general location in the electronics bay of the airplane is also consistent with a burning fuel leak from a pressurized system. It is possible that the arcing or dead short drew excessive current, causing a battery to explode; this is supported by the conditions of the batteries and tiedowns. Two of the battery tiedown bolts were nearly straight, indicating the likelihood that they were not restraining substantial battery mass at the time of impact. Battery explosion, specifically the left battery, could have compromised a fuel line. A fracture at the motive flow valve could have resulted in a high pressure (300 psi) spray that became ignited and impinged upon the aft engine support beam. The fact that the inlet fitting of the left motive flow valve was

gone and the threads inside the valve were undamaged is consistent with a leak at that location.

It is also possible that the alcohol tank pressurization tube was melted through by the fire early in the sequence. The tube was not found in the wreckage; there was extensive fire damage in the aft fuselage area, and many nearby components were consumed or found partially melted. However, any compromise of the tube, early in fire propagation in the tailcone area, would have resulted in a ready source of engine bleed air into this enclosed space. There was evidence of soot in the aft tail section, specifically around lightening holes between the tail cone and vertical stabilizer; however, there was no evidence of severe smoke exit points from the fuselage. Further, most witnesses saw either no smoke or only light gray smoke trailing from the airplane before impact. Increased pressure flow from bleed air, impinging into the tailcone area, would have created a hotter fire, resulting in less smoke than expected emitting from the fuselage.

2.3 Airplane Handling

The reason the flightcrew was unable to successfully land the airplane could not be conclusively determined. The 2 minutes of tower-recorded intracockpit communications between the pilots prior to impact failed to provide sufficient data to determine the controllability of the airplane. The installation of a CVR and/or an FDR would have facilitated the determination of the events that led to the unsuccessful attempt to land the airplane. The Safety Board has addressed improved requirements for the installation and upgrading of CVR and FDR requirements for many facets of the aviation system. Although the installation of CVRs and FDRs are certainly important for passenger flight operations, they are also important for unique flight operations of aircraft with special mission equipment that operate over populated areas. This issue will be examined in the future by the Safety Board, and additional safety recommendations regarding operations, such as the accident flight, will be developed as appropriate.

It is possible that the in-flight fire caused sufficient damage to the airplane structures and systems to render the airplane only partially controllable. Although examination of the wreckage did not reveal a definitive reason for the loss of control, there is evidence that severe fire damage in the aft fuselage area occurred while the airplane was airborne.

Regarding engine power, the first officer asked the captain about 1 minute before impact, "do we have any power?" and the captain replied, "I'm not getting any response, man." However, engine disassembly evidence showed that although there was no indication of power on the left engine at impact, and it was only "windmilling," there was evidence of at least flight idle power on the right engine. In response to the first officer's urging, "pull up dude," the captain replied about 35 seconds before impact, "I've got full right rudder in."¹⁴ In the absence of unknown flight control anomalies affecting directional control, this is consistent with asymmetrical thrust resulting from all or most of the power coming from the right engine. It is not known which cockpit indications, if any, the flightcrew had prior to impact to assist them in determining whether they had any engine power, or whether the indications were confusing due to electrical shorting and fire in the electronics bay in the aft fuselage. However, absent, incomplete, or misleading cockpit indications, combined with likely control malfunctions, specifically near full nose-down trim, led to an airplane condition that became increasingly difficult to control and difficult to diagnose.

The damage to the aft engine support beam confirms that there was a severe fire directed onto this aluminum structure. The aluminum structure for the beam was melted and missing for a considerable distance within the fuselage. It is possible that elevator and rudder control mechanisms were damaged by the fire and caused the loss of control.

It is also possible that the loss of control related to the findings of the elevator trim about 1 degree from full nose down and the spoiler switch in the deployed position. Again, impact and postcrash fire damage precluded a determination of why the elevator trim was found near full nose down. Perhaps, the pilots activated the trim to compensate for other elevator problems, or the trim may have been activated by the fire in flight.

There was no confirming physical evidence of spoiler deployment other than a guarded selector switch that was found in the deployed position. However, the possibility of deployed spoilers prior to impact is real because the pilots might have had reason to use them momentarily to slow the airplane for landing. If they

¹⁴The father of the first officer listened to the air traffic control recording of the flight (see letter, Appendix B) and identified the first officer and captain, respectively, as the pilots making the statements quoted in this sentence. This is the reverse attribution to that which was made on the transcript after mission pilots who had known the flightcrew listened to the tape. The father's determination regarding the attributions for these two quotations appears correct.

did, there also could have been electrical anomalies caused by the in-flight fire that prevented spoiler retraction, or the pilots may have forgotten to retract them.

However, even if the elevator trim and/or spoilers were misconfigured during the final phase of the emergency landing, the pilots should have been able to overcome the forces involved. Additionally, the observations of the various witnesses do not match a scenario in which the airplane is "nose heavy" and slowing. Rather, it was described as "fast" and in a position to make the runway before it flew through the runway centerline, "porpoised," went out of control, and crashed. Lastly, the comments by the pilots recorded on the ATC tape during the last moments of the flight do not provide any clear explanation for the loss of control.

The Safety Board concludes that the pilots were unable to control the airplane during the final moments of the flight because of fire damage to structures and/or systems, and that they were possibly diverted by conflicting input resulting from the in-flight fire.

2.4 Maintenance Oversight

The USAF and ANG did not play a direct role in the circumstances that led to the accident because they were not responsible for the actual installation of the special mission wiring or for the inspection of the installation. In accordance with the USAF contract for services, the contractor specified that the airplane be maintained in accordance with FAA regulations. It is understandable that the USAF and ANG would rely on the FAA-approved maintenance program and the FAA-approved Form 337 installation of the special mission wiring. Although the USAF did have oversight authority and responsibilities under the contract, it would not necessarily inspect FAA-approved installations. If it were not for the DOD's responsibility to assess the operator's ability to continue providing safe and reliable airlift support under the provisions of a Military Traffic Command tender of service for passenger and cargo operations, there would likely have been no safety survey. Rather, the USAF inspections involved broader matters related to the maintenance and operation of the contract airplanes. Nevertheless, the USAF's inspection program for this operator was less comprehensive than FAA oversight of Part 135 aircraft operators. Although the USAF had specified that the operator must use an FAA-approved maintenance program, this did not diminish the fact that the airplane was being operated as a public-use aircraft requiring USAF oversight. The Safety Board believes that the DOD should have provided audits of contractor maintenance

actions on specific aircraft. To this end, a centralized command for oversight of contracted aircraft services to all DOD components (U.S. Army, USAF, etc.) could help to ensure that oversight is provided in a variety of conditions.

Because the operation was considered public use, technically, the operator did not have to comply with FAA regulations; however, the operator did maintain the airplane in accordance with such regulations. Consequently, when the special mission equipment was installed, it was supposed to be installed in accordance with the provisions of the Form 337. The original Form 337 was reviewed and approved by an FAA avionics inspector in 1989. Consequently, when the installation was done on N521PA, a new Form 337 was created without the need for FAA approval because it was based on the originally approved document.

The use of the FAA Form 337 for approval of the installation of the special mission equipment, and the fact that a Phoenix Air mechanic holding IA privileges signed off on the installation procedures, placed the responsibility for quality and oversight of the installation on the operator. The operator failed in these responsibilities.

The Safety Board believes that a qualified mechanic should not have overlooked basic electrical power wire installation practices, such as ensuring proper current overload protection for the entire system. Similarly, the failure of the FAA-certified avionics inspector to compare the actual installation with the specified installation instructions is inexcusable. The instructions for the work specified the proper installation; however, it was not followed by the mechanic, and the IA did not meet his inspection responsibilities. These failures, coupled with the fact that 14 additional airplanes had been modified incorrectly, reflect on the competence of the individuals involved and a lack of adequate oversight by the operator's maintenance management personnel.

Subsequent to the operator's grounding and inspection of the other airplanes, the ANG temporarily halted the mission. After a new Form 337 was written and approved that included more detailed instructions on the proper installation, and the airplanes were modified correctly, the ANG mission was reinstated.

2.5 Survival Factors

The accident was not survivable for the two pilots because of the severe impact forces and destruction of the airplane during the crash sequence. Additional loss of life was avoided because the airplane crashed into a street that was not crowded with other persons. Although a severe ground fire occurred after the impact and several vehicles and residences were destroyed as a result, no persons on the ground lost their lives. The Safety Board concludes that the pilots were unable to land the airplane successfully on the intended runway because of in-flight fire-induced damage. However, it is very possible that they had control of some axes (roll and yaw) and partial control of pitch during the final descent and that they were able to avoid buildings during the crash landing.

Postcrash fire and rescue actions were timely and effective. The City of Fresno Fire and Police Departments, significantly assisted by a foam truck from FAT, secured the two-block burning area and knocked down the fires in an organized fashion. Their actions were particularly effective considering the number of persons in affected apartments, the substantial aircraft wreckage, and apartment building and vehicles fires. Command and control was well organized and expedited the dispatching of injured persons through the early establishment of an ambulance control center near the impact site.

3. CONCLUSIONS

3.1 Findings

1. Weather was not a factor in the accident.
2. Air traffic services were proper and did not contribute to the causes of the accident.
3. The pilots were properly trained and qualified for the flight.
4. The flightcrew experienced an in-flight fire leading to a request for an emergency landing.
5. The special mission wiring was not installed properly, leading to a lack of overload current protection.
6. The FAA Form 337s provided instructions for the correct installation, and the mission power modifications made by another operator on 3 of the 18 special mission Learjets were correct.
7. Neither the mechanic(s) who installed the wiring nor the mechanic(s) holding the inspection authorization, who approved the installation, noted the nonconformity with the FAA Form 337 in the installation on N521PA and 14 other Learjets modified by the operator.
8. The in-flight fire most likely originated with a short of the special mission power supply wires in an area unprotected by current limiters.
9. The fire resulted in false engine fire warning indications to the pilots that led them to a shutdown of the left engine.
10. The intense fire, which burned through the aft engine support beam in flight, can be explained by a compromised fuel line resulting from a battery explosion.

11. The in-flight fire caused substantial damage to the airplane structure and systems in the aft fuselage and may have precluded a successful emergency landing.
12. At the time of impact, the left engine was not producing power; and the right engine was producing at least flight-idle power.
13. The City of Fresno police, fire fighting, and rescue responses, which were assisted by units from Fresno Air Terminal, were timely and effective.

3.2 Probable Cause

The National Transportation Safety Board determines that the probable causes of this accident were: 1) improperly installed electrical wiring for special mission operations that led to an in-flight fire that caused airplane systems and structural damage and subsequent airplane control difficulties; 2) improper maintenance and inspection procedures followed by the operator; and, 3) inadequate oversight and approval of the maintenance and inspection practice by the operator in the installation of the special mission systems.

4. RECOMMENDATIONS

As a result of the investigation of this accident, the National Transportation Safety Board makes the following recommendations:

--to the Federal Aviation Administration:

Publish an FAA Special Airworthiness Information Bulletin that describes the circumstances of this accident, including the consequences of improper installation of the special mission wiring, where electrical power wires were unprotected by current limiters. In addition, emphasize that all major aircraft repairs and alterations requiring an FAA Form 337 must be performed in strict accordance with the technical data contained in the FAA Form 337, and that it is unacceptable to use similar work done on another aircraft as a technical guide in lieu of the information on the FAA Form 337. (Class II, Priority Action) (A-95-79)

--to the Department of Defense:

Centralize contractual oversight for safety for all Department of Defense components using contracted aircraft services. (Class II, Priority Action) (A-95-147)

--to Phoenix Air:

Conduct an in-depth audit of your maintenance program to ensure that all work is being done in accordance with applicable Federal Aviation Regulations, and particularly to ensure that mechanics and others involved in aircraft maintenance are consulting proper technical data when performing and inspecting aircraft. (Class II, Priority Action) (A-95-80)

BY THE NATIONAL TRANSPORTATION SAFETY BOARD

James E. Hall

Chairman

Robert T. Francis II

Vice Chairman

John Hammerschmidt

Member

August 1, 1995

**Intentionally Left Blank
in Original Document**

5. APPENDIXES

APPENDIX A

INVESTIGATION AND HEARING

1. Investigation

The National Transportation Safety Board was notified of the accident by the FAA Command Center about 1700 eastern standard time on December 14, 1994. The Safety Board investigator in charge and the FAA party coordinator departed for the accident site on the first available commercial flight. Safety Board group chairmen arrived at the site by commercial air from the South Central Regional Office, Fort Worth, Texas, and the Southeast Field Office, Atlanta, Georgia. Safety Board personnel from the Southwest Regional Office, Los Angeles, California, were the first investigators to reach the site, arriving at approximately 0200 on December 15, 1994.

Investigation groups were formed on site for: Aircraft Structures and Systems, Fire, Maintenance Records, Operations and Witnesses, and Powerplants.

Although there was neither a CVR nor FDR in the airplane, a Safety Board CVR specialist examined the ATC transcript due to the availability of intra-cockpit transmissions during the final minutes of flight.

Parties to the investigation were: the Federal Aviation Administration, Allied Signal Aerospace, California Air National Guard, City of Fresno Department of Airports, City of Fresno Police and Fire Departments, Learjet, National Air Traffic Controllers Association, National Business Aircraft Association, Inc., Phoenix Air, and the U.S. Air Force Safety Agency.

2. Public Hearing

There was no public hearing held or formal depositions taken for this accident.

APPENDIX B**AIR TRAFFIC CONTROL TRANSCRIPT**

Transcript of an FAA Air Traffic Control tape. The transcript involves Dart 21, a Learjet 35A, N521EA, which was involved in a collision with terrain near Fresno, California, on December 14, 1994.

LEGEND

RDO	Radio transmission from accident aircraft
APR	Radio transmission from Fresno approach control
TWR	Radio transmission from Fresno tower
-1	Voice identified as Pilot-in-Command (PIC)
-2	Voice identified as Co-Pilot
-?	Voice unidentified
*	Unintelligible word
@	Non pertinent word
#	Expletive
%	Break in continuity
()	Questionable insertion
[]	Editorial insertion
....	Pause

Note: Times are expressed in pacific standard time (PST).

INTRA-COCKPIT COMMUNICATION

AIR-GROUND COMMUNICATION

TIME & SOURCE	CONTENT	TIME & SOURCE	CONTENT
--------------------------	----------------	--------------------------	----------------

START of RECORDING

START of TRANSCRIPT

APPROACH CONTROL RECORDING

1141 36 RDO-2	Fresno, Dart two one's with ya out of ah, eleven five for eleven, kilo
1141 40 APR	Dart two one, Fresno approach roger fly your present heading, vectors for sequencing. descend and maintain seven thousand and say your request
1141 44 RDO-2	visual
1141 46 APR	roger
1143.13 APR	Dart two one, descend and maintain four thousand, heading two niner zero.
1143 16 RDO-2	declare an emergency. engine fire. immediate vectors
1143:19 APR	uh who was that? I cut you out was that Dart two one?

INTRA-COCKPIT COMMUNICATION

AIR-GROUND COMMUNICATION

TIME & SOURCE	CONTENT	TIME & SOURCE	CONTENT
		1143:21 RDO-2	affirmative.
		1143:23 APR	Dart two one roger. maintain two thousand. fly heading ah, two three zero vectors to the airport.
		1143:25 RDO-2	two three zero.
		1143:57 APR	Dart two one, the airport twelve o'clock and about ah, six miles.
		1144:00 RDO-2	Dart two one.
		1144:01 APR	Dart two one, airport twelve o'clock six miles.
		1144:07 APR	Dart two one, do you want ah, one one or two nine?
		1144:10 RDO-2	two nine please... say the wind.
		1144:14 APR	Dart two one, the wind is uh, one one zero at six.
		1144:21 APR	Dart two one, the airport is ah, twelve o'clock and about ah, four miles.
		1144:23 RDO-2	the field in sight.

INTRA-COCKPIT COMMUNICATION**AIR-GROUND COMMUNICATION**

TIME & SOURCE	CONTENT	TIME & SOURCE	CONTENT
		1144:25 APR	Dart two one, cleared visual approach runway two niner right. contact the tower on ah, one one eight point two.
		1144:31 RDO-2	(goin' to) the tower.

TOWER RECORDING

1144:54 RDO-2	base for emergency.
1144:58 TWR	Dart two one, runway two nine right, cleared to land. wind's one one zero at five.
1145:01 RDO-2	*, I think you're gonna need to do a two seventy.
1145:04 TWR	'K Dart, one approved. cleared to land runway two nine right.
1145:07 RDO-2	tower Dart two one.
1145:09 RDO-1	ya,
1145:11 RDO-1	we got an engine fire on the right side too it shows.
1145:15 RDO-2	##.... do we have any power?

INTRA-COCKPIT COMMUNICATION

AIR-GROUND COMMUNICATION

TIME & SOURCE	CONTENT	TIME & SOURCE	CONTENT
		1145:17 RDO-1	I'm not getting any response, man.
		1145:19 RDO-2	gear's coming down. pull it in.
		1145:22 RDO-1	I'm coming, I'm coming, I'm not gonna...
		1145:29 RDO-2	##.
		1145:34 RDO-2	full power, full power....pull up.
		1145:38 RDO-1	I, dammit.... [sound of static] pull up dude.
		1145:48 RDO-2	(I've got) full right rudder in.
		1145:50 RDO-2	oh Christ.
		1145:52 RDO	[sound of static]
		1145:54 RDO-1	get..
		1145:57 RDO-1	c'mon baby, don't crash on me now.
		1146:03 RDO	*** it that's all she wrote. [twenty seconds of garbled transmissions]

INTRA-COCKPIT COMMUNICATION**AIR-GROUND COMMUNICATION**

TIME & SOURCE	CONTENT	TIME & SOURCE	CONTENT
		1146:21 RDO-1	oh God.
		1146:22 RDO-1	oh God.
		1146:23 RDO-2	no no.

END of RECORDING

END of TRANSCRIPT

JACQUE M. SEXTON

6 SEQUOIA WAY
REDWOOD CITY, CA 94061

May 22, 1995

MR ALBERT G REITAN
Transportation Safety Specialist (CVR)
National Transportation Safety Board

Dear Mr Reitan,

My family and I are most grateful to have received the tape transcripts of the Learjet crash in Fresno on December 14, 1994. My son, Capt Brad Sexton and Capt Richard Anderson were the two pilots who were killed.

We all have listened to the tape with great care and we feel that there are a few inadvertent mistakes in voice identification. Because we wanted to be sure of our conclusions we invited two of the pilots Brad and Richard flew with at the Phoenix Air detachment at Kingsley Field Air National Guard Base in Klamath Falls, OR. Both of them agreed positively with our conclusion, The two pilots are Capt Doug Tippet and Capt Mary Hook who flew with Brad and Richard for at least three years.

I am enclosing a copy of the NTSB transcript with the voices identified as we believe they should be. This has been agreed to by myself, Brad's wife, mother, two brothers and the two pilots from Klamath Falls.

Sincerely,

JACQUE M SEXTON
UNITED AIR LINE CAPTAIN (RET)

Enclosure 1

+ cc Ralph E. Hulse, Jr

INTRA-COCKPIT COMMUNICATION

AIR-GROUND COMMUNICATION

TIME &
SOURCE

CONTENT

TIME &
SOURCE

CONTENT

1145:17
RDO-1 I'm not getting any response, man.

1145:19
RDO-2 gear's coming down. pull it in.

1145:22
RDO-1 I'm coming, I'm coming, I'm not gonna...

1145:29
RDO-2 ##.

1145:34
RDO-2 full power, full power....pull up.

1145:38
RDO-1 ^{RDO 1} I, dammit... [sound of static] ^{RDO 2} pull up dude.

1145:48
RDO-2 ^{RDO 1} (I've got) full right rudder in.

1145:50
RDO-2 oh Christ.

1145:52
RDO [sound of static]

1145:54
RDO-1 get..

1145:57
RDO-1 c'mon baby, don't crash on me now.

1146:03
RDO *** it that's all she wrote. [twenty seconds of garbled transmissions]

APPENDIX C

FAA FORMS 337 REGARDING SPECIAL MISSION WIRING INSTALLATION

 U.S. Department of Transportation Federal Aviation Administration		MAJOR REPAIR AND ALTERATION (Airframe, Powerplant, Propeller, or Appliance)		Form Approved OMB No. 2120-0020 For FAA Use Only Office Identifying	
INSTRUCTIONS: Print or type all entries. See FAR 43.9, FAR 43 Appendix B, and AC 43.9-1 (or subsequent revision thereof) for instructions and disposition of this form. This report is required by law (49 U.S.C. 1421). Failure to report can result in a civil penalty not to exceed \$1000 for each such violation (Section 901 Federal Aviation Act of 1958).					
1. Aircraft	Make Texaco	Model 35A		Nationality and Registration Mark N221PA	
	Serial No. 239				
2. Owner	Name (As shown on registration certificate) Phoenix Air Group, Inc.		Address (As shown on registration certificate) 100 Phoenix Air Drive, S.W. Cartersville, GA 30120		
3. For FAA Use Only					
4. Unit Identification					
Unit	Make	Model	Serial No.	Repair	Alteration
AIRFRAME	(As described in Item 1 above)				X
POWERPLANT					
PROPELLER					
APPLIANCE	Type				
	Manufacturer				
5. Conformity Statement					
A. Agency's Name and Address		B. Kind of Agency		C. Certificate No.	
Jerrold L. Frank 7 Iron Belt Road Cartersville, GA 30120		<input checked="" type="checkbox"/> U.S. Certified Mechanic <input type="checkbox"/> Foreign Certified Mechanic <input type="checkbox"/> Certified Repair Station <input type="checkbox"/> Manufacturer		A&P 166620306	
D. I certify that the repair and/or alteration made to the unit(s) identified in Item 4 above and described on the reverse or attachments hereto have been made in accordance with the requirements of Part 43 of the U.S. Federal Aviation Regulations and that the information furnished herein is true and correct to the best of my knowledge.					
Date 10/22/92		Signature of Authorized Individual <i>Jerrold L. Frank</i> / Jerrold L. Frank			
7. Approval for Return To Service					
Pursuant to the authority given persons specified below, the unit identified in Item 4 was inspected in the manner prescribed by the Administrator of the Federal Aviation Administration and is <input checked="" type="checkbox"/> APPROVED <input type="checkbox"/> REJECTED					
BY	FAA Fit. Standards Inspector	Manufacturer	<input checked="" type="checkbox"/> Inspection Authorization <input type="checkbox"/> Other (Specify)		
	FAA Designee	Repair Station	Person Approved by Transport Canada Airworthiness Group		
Date of Approval or Rejection 10/22/92		Certificate or Designation No. CA 464139686		Signature of Authorized Individual <i>Thomas M. Anselman</i> / Thomas M. Anselman	

NOTICE

Weight and balance or operating limitation changes shall be entered in the appropriate aircraft record. An alteration must be compatible with all previous alterations to assure continued conformity with the applicable airworthiness requirements.

8. Description of Work Accomplished

(If more space is required, attach additional sheets. Identify with aircraft nationality and registration mark and date work completed.)

SUBJECT: WIRING ADDED TO AIRCRAFT TO PROVIDE HIGH CURRENT WITHIN THE MAIN CABIN.

Three hundred amps of DC power was made available for cabin use in running ECM sources while aircraft was operated in restricted category as defined under public use. Connection for this power category was made within the generator control panel at Station 473 using a pair of #0 awg wires. Reference Lear Wiring Manual page 34-31-00 which covers this aircraft. The two #0 awg wires are routed to Station 459 where two 150 amp current limiters provide circuit protection. The two #0 wires exit their independent limiter and attach to main contactor relay XM-1 at Station 457. This relay is controlled within the cockpit by a switch available to the flight crew. Safety is built into the system with an added voltage monitor at Station 489 that samples the generator control buss's to ensure both are energized before allowing the cockpit on/off switch to be effective. This monitor will shut down the system by disengaging XM-1 in the event one generator fails or output voltage drops below 122 volts. This prohibits powering while on batteries only. The monitor circuit allows a ground power source to enable XM-1 for ground testing and operation. Tied together on the output side of XM-1 both #0 awg wires run through Learjet's electrical conduit and enter the cabin at Station 421 with six feet of length each. They are then terminated while in public use to a 9KVA, 30 power generating source. (Reference Jet Electronics Service Center SL-21E, Page 12.) Under Part 135 use, the power wires are terminated at phenolic insulating blocks. Both current limiters are removed from the circuit in this configuration.

Wiring was also installed from the cabin area at Station 258 to the external wing stores, which were previously installed. The wiring is bundled to separate it from the existing wiring and routed under the armrest on the right side of the aircraft. The wiring exits the cabin area at Station 378. The wiring enters the wing in the wheel well area. It is then routed through the dry bay area of the wing and exits the wing through an inspection panel. The wiring is secured to the wing using covers, which are part of the wing store STC installation. The wiring terminates at the wing stores and is secured there during 135 operations. The wiring mentioned here is only used while the aircraft is in public use category. There is no electric power in the wiring while in Part 135.

No chaffing or clearance problems exist with this installation. This installation does not interfere with any other previously installed systems.

Operation and function test confirms that the circuit is operating safely and normally within specifications stated within. Methods and techniques used in this installation were consistent with practices recommended by Advisory Circulars 43.13-1A Chapters 11, 13, 15, 16 and 43.13-2A Chapters 1 and 2.

Standard Aircraft AN and MS materials were used.

An electrical load analysis was made and determined that at 100% of rated draw, the air conditioner must be off. Weight and balance was updated to reflect this installation.

Attached to this 33/ is an approved 377 dated 02/27/89.

[X Additional Sheets Are Attached

DEPARTMENT OF TRANSPORTATION FEDERAL AVIATION ADMINISTRATION				Form Approved Budget Bureau No. 01-R900.1	
MAJOR REPAIR AND ALTERATION (Airframe, Powerplant, Propeller, or Appliance)				FOR FAA USE ONLY	
				OFFICE OF IDENTIFICATION 7-0-11	
INSTRUCTIONS: Print or type all entries. See FAR 43.9, FAR 43 Appendix B, and AC 43.9-1 (or subsequent revision thereof) for instructions and disposition of this form.					
1. AIRCRAFT	MAKE	LEAR JET		MODEL	36A
	SERIAL NO.	028		NATIONALITY AND REGISTRATION MARK	N75TD
2. OWNER	NAME (As shown on registration certificate)			ADDRESS (As shown on registration certificate)	
	PHOENIX AIR GROUP, INC.			177 HIGHWAY 61, S.E. CARTERSVILLE, GA 30120	
3. FOR FAA USE ONLY					
<p>THE DATA SUBMITTED HEREIN COMPLIES WITH APPLICABLE AIRWORTHINESS REQUIREMENTS AND IS APPROVED ONLY FOR THE ABOVE DESCRIBED AIRCRAFT SUBJECT TO CONFORMITY INSPECTION BY A PERSON AUTHORIZED IN FAR 43.7</p> <p>MAR 17 1999 <i>[Signature]</i> FAA INSPECTOR</p> <p style="text-align: right;">dupl. AUTH.</p>					
4. UNIT IDENTIFICATION				5. TYPE	
UNIT	MAKE	MODEL	SERIAL NO.	REPAIR	ALTERATION
AIRFRAME	***** (As described in item 1 above) *****				X
POWERPLANT					
PROPELLER					
APPLIANCE	TYPE				
	MANUFACTURER				
6. CONFORMITY STATEMENT					
A. AGENCY'S NAME AND ADDRESS			B. KIND OF AGENCY		C. CERTIFICATE NO.
ROBERT DAVICK WATKINS, III 23 SIMMONS DRIVE, S.W. CARTERSVILLE, GA 30120			<input checked="" type="checkbox"/> U.S. CERTIFICATED MECHANIC <input type="checkbox"/> FOREIGN CERTIFICATED MECHANIC <input type="checkbox"/> CERTIFICATED REPAIR STATION <input type="checkbox"/> MANUFACTURER		A/P 465889538
D. I certify that the repair and/or alteration made to the unit(s) identified in item 4 above and described on the reverse or attachments hereto have been made in accordance with the requirements of Part 43 of the U.S. Federal Aviation Regulations and that the information furnished herein is true and correct to the best of my knowledge.					
DATE			SIGNATURE OF AUTHORIZED INDIVIDUAL		
2/27/89			<i>[Signature]</i> ROBERT DAVICK WATKINS, III		
7. APPROVAL FOR RETURN TO SERVICE					
Pursuant to the authority given persons specified below, the unit identified in item 4 was inspected in the manner prescribed by the Administrator of the Federal Aviation Administration and is <input checked="" type="checkbox"/> APPROVED <input type="checkbox"/> REJECTED					
FAA FLT. STANDARDS INSPECTOR	MANUFACTURER	<input checked="" type="checkbox"/>	INSPECTION AUTHORIZATION	OTHER (Specify)	
FAA DESIGNEE	REPAIR STATION		CANADIAN DEPARTMENT OF TRANSPORT INSPECTOR OF AIRCRAFT		
DATE OF APPROVAL OR REJECTION	CERTIFICATE OR DESIGNATION NO.	SIGNATURE OF AUTHORIZED INDIVIDUAL			
5/27/89	465889538 T/A	<i>[Signature]</i> ROBERT DAVICK WATKINS, III			

NOTICE

Weight and balance or operating limitation changes shall be entered in the appropriate aircraft record. An alteration must be compatible with all previous alterations to assure continued conformity with the applicable airworthiness requirements.

8. DESCRIPTION OF WORK ACCOMPLISHED (If more space is required, attach additional sheets. Identify with aircraft nationality and registration mark and date work completed.)

SUBJECT: WIRING ADDED TO AIRCRAFT TO PROVIDE HIGH CURRENT WITHIN THE MAIN CABIN.

Three hundred amps of DC power was made available for cabin use in running ECM sources while aircraft operated in restricted category as defined under public use. Connection for this power category was made within the generator control panel at station 473 using a pair of #0 awg wires. Reference Lear wiring manual, page 24-31-00 which covers this aircraft. (See Exhibit A.) The two #0 awg wires are routed to station 459 where two 150 amp current limiters provide circuit protection. The two #0 wires exit their independent limiter and attach to main contactor relay XM-1 at station 457. This relay is controlled within the cockpit by a switch available to the flight crew. Safety is built into the system with an added voltage monitor at station 498 that samples the generator control buss's to ensure both are energized before allowing the cockpit on/off switch to be effective. (Reference Exhibit A, P862 and P836 Pin A of each.) This monitor will shut down the system by disengaging XM-1 in the event one generator fails or output voltage drops below +22 volts. This prohibits powering while on batteries only. The monitor circuit allows a ground power source to enable XM-1 for ground testing and operation. Tied together on the output side of XM-1 both #0 awg wires run through learjet's electrical conduit and enter the cabin at station 378 with six feet of length each. They are then terminated while in public use to a 9KVA, 30 power generating source. (Reference Jet Electronics Service Center SL-21E, Page 12 - Exhibit B.) Under Part 135 use, the power wires are terminated at phenolic insulating blocks. Both current limiters are removed from the circuit in this configuration.

Wiring was also installed from the cabin area at station 258 to the external wing stores, which were previously installed. The wiring is bundled to separate it from the existing wiring and routed under the armrest on the right side of the aircraft. The wiring exits the cabin area at station 378. The wiring enters the wing in the wheel well area. It is then routed through the dry bay area of the wing and exits the wing through an inspection panel. The wiring is secured to the wing using covers, which are part of the wing store STC installation. The wiring terminates at the wing stores and is secured there during 135 operations. The wiring mentioned here is only used while the aircraft is in public use category. There is no electric power in the wiring while in Part 135.

No chaffing or clearance problems exist with this installation. This installation does not interfere with any other previously installed systems.

ADDITIONAL SHEETS ARE ATTACHED

27 Feb., 1989
N75TD

Operation and function test confirms that the circuit is operating safely and normally within specifications stated within. Methods and techniques used in this installation were consistent with practices recommended by Advisory Circulars 43.13-1A Chapters 11, 13, 15, 16 and 43.13-2A Chapters 1 and 2.

Standard Aircraft AN and MS materials were used.

An electrical load analysis was made and determined that at 100% of rated draw, the air conditioner must be off. Weight and balance was updated to reflect this installation.