Oily fumes on approach producing sickness, BAe 146-200, G-JEAK

Micro-summary: The crew of this BAe 146-200 felt sick after detecting oily fumes on approach.

Event Date: 2000-11-05 at 1410 UTC

Investigative Body: Aircraft Accident Investigation Board (AAIB), United Kingdom

Investigative Body's Web Site: <http://www.aaib.dft.gov/uk/>

Note: Reprinted by kind permission of the AAIB.

Cautions:

1. Accident reports can be and sometimes are revised. Be sure to consult the investigative agency for the latest version before basing anything significant on content (e.g., thesis, research, etc).
 2. Readers are advised that each report is a glimpse of events at specific points in time. While broad themes permeate the causal events leading up to crashes, and we can learn from those, the specific regulatory and technological environments can and do change. ***Your company's flight operations manual is the final authority as to the safe operation of your aircraft!***
 3. Reports may or may not represent reality. Many many non-scientific factors go into an investigation, including the magnitude of the event, the experience of the investigator, the political climate, relationship with the regulatory authority, technological and recovery capabilities, etc. It is recommended that the reader review all reports analytically. Even a "bad" report can be a very useful launching point for learning.
 4. Contact us before reproducing or redistributing a report from this anthology. Individual countries have very differing views on copyright! We can advise you on the steps to follow.
-

BAe 146-200, G-JEAK

Contents

Aircraft Accident Report No: 1/2004 (EW/C2000/11/4)	2
Synopsis	3
1. Factual Information	3
2. Analysis	27
3. Conclusions	35
4. Safety Recommendations	37
5. Figures and Appendices	40
Appendix 1: ATSB Safety Recommendations R19990052/3 Responses	46
Appendix 2: SHK Safety Recommendations Responses	47
Appendix 3: CAA FODCOM 17/2000	48
Appendix 4: CAA FODCOM 14/2001	49
Appendix 5: CAA FODCOM 21/2002	50

Air Accidents Investigation Branch

Aircraft Accident Report No: 1/2004 (EW/C2000/11/4)

Registered Owner	Jersey European Airways (UK) Ltd
Operator	British European
Aircraft Type	BAe 146-200
Nationality	British
Registration	G-JEAK
Place of Incident	During descent into Birmingham Airport
Date and Time	5 November 2000 at 1410 hrs (all times in this report are in UTC)

Synopsis

This incident was notified to the Air Accidents Investigation Branch (AAIB) at 1530 hrs on 10 November 2000. The investigation was conducted by Dr E J Trimble Inspector in Charge (IIC), Mr R W Shimmons (Operations), Mr P T Claiden (Engineering). During the course of the investigation Mr P T Claiden replaced Dr E J Trimble as IIC and Mr P A Sleight (Engineering) continued the engineering investigation.

The incident occurred whilst on approach to Birmingham Airport. Following reports of unusual "oily petrol" smells in the cabin, the first officer, after visiting the cabin started to feel nauseous. The first officer's condition began to decline to an extent that he had difficulty in concentrating. The commander took over the handling duties and the first officer went onto 100% oxygen, and took no further part in the flight. The commander also felt "light headed" and had difficulty in judging height during the ensuing approach and landing. Following a successful landing, the commander was able to taxi the aircraft and began to feel better. The first officer and commander were taken to hospital and examined, but no abnormalities were found.

An engineering investigation revealed the presence of an oil leak from the auxiliary power unit (APU) generator cooling fan seal, which allowed engine turbine oil to enter the APU air inlet plenum chamber and, subsequently, fumes to enter the cabin via the Environmental Control System (ECS).

During the investigation, further incidents involving other aircraft types were reported. Therefore, the scope of the investigation was widened to include these other incidents.

The following causal factors were concluded during the investigation:

1.	There is circumstantial evidence to suggest that the flight crew on G-JEAK were affected by contamination of the air supply, as a result of oil leakage from the APU generator cooling fan seal into the APU air stream, and into the ECS system ducting. This contamination allowed fumes to develop, a proportion of which entered the cabin and cockpit air supply.
2.	Subsequent research and tests suggests that the crew of G-JEAK, and the crew of other aircraft which have suffered similar incidents, may have been exposed to turbine engine oil derived fumes in the cabin/cockpit air supply, originating from either an engine or APU, which had an irritant, rather than a toxic effect.

Five safety recommendations were made during the course of this investigation.

1. Factual Information

1.1 History of the flight

The crew reported for duty at 1000 hrs to fly a return flight from Birmingham International Airport to Paris (Charles de Gaulle) Airport. The flight from Birmingham to Paris was uneventful with no unserviceabilities noted with the aircraft. At Paris, the crew remained on the aircraft apart from when the first officer, who was the designated 'Pilot Flying' (PF) for the subsequent sector, carried out the transit external inspection. A normal engines start was completed, the aircraft was pushed back and it then taxied to Runway 09 Left for departure; because of the traffic density, the time between pushback and take off was 35 minutes. The takeoff at 1340 hrs was normal using the calculated reduced power setting.

During the climb, the senior cabin attendant (SCA) entered the flight deck to report that two passengers towards the left rear of the cabin had informed her that they had noticed an oily/petrol like smell. In addition, a cabin crew member of a company BAe 146 positioning crew had also reported a similar smell; the positioning crew were located in the front right of the cabin but neither the captain

nor the first officer of that crew had noticed any unusual smell. The commander of G-JEAK asked the SCA to go back to the rear of the cabin to check the situation. She did so and reported that she could detect nothing unusual. The commander then instructed her to advise him if there were any further indications.

The first officer established the aircraft in the cruise at Flight Level (FL)240 and all flight deck indications appeared normal. Towards the end of the cruise, the commander left his seat to go to the toilet located at the front of the cabin. Prior to returning to the flight deck, he stood with the SCA in the forward galley and detected nothing unusual. He was then aware of the aircraft beginning to descend and returned to the flight deck. Shortly afterwards, the first officer left his seat to go to the front cabin toilet and then also spent a few minutes in the front galley talking with the SCA; he detected no unusual smells.

However, as he entered the flight deck, he began to feel nauseous. He sat in his seat but began to feel progressively worse, although his workload was low. He felt 'light-headed' and had difficulty in concentrating. He was aware of a tingling feeling in his fingertips and his arms started shaking.

At about this time the commander also began to feel nauseous and asked the first officer how he felt. The first officer replied that he "felt dreadful" and the commander looked at him and saw that his face was white and that his pupils appeared highly dilated. The commander took over the handling duties, instructed the first officer to put on his oxygen mask and called the SCA to the flight deck. When she arrived, the first officer was on 100% oxygen, his seat was well back from the aircraft controls and his hands were seen to be trembling. The commander instructed her to check the flight deck regularly during the descent and approach. Thereafter, the first officer took no part in the conduct of the flight although he was able to nod in response to the commander's questions. There were no reports of other crew members or passengers, who might have used the forward toilet, suffering similar symptoms to the flight crew,

By this stage, the aircraft was at approximately FL70, to the west of Birmingham, and positioning for an ILS approach to Runway 15. The commander was feeling progressively worse. He felt light-headed and recalled considering three aspects: landing, declaring an emergency and putting on his oxygen mask. However, he felt able to cope only with one decision and continued with his approach. The commander considered that he was subsequently able to complete all of the necessary checks and maintained normal radio contact with ATC. However, he reported that his heart was 'racing' and his mouth was dry. Additionally, when he became visual with the runway at about 1,000 to 1,500 feet agl, the commander seemed to have 'double vision' and had difficulty in judging height. The aircraft was fully configured for landing with full flap and the commander kept the autopilot engaged until about 150 feet agl; he described the subsequent landing at 1439 hrs as "firm". The commander noted afterwards that it was all he could do just to land the aircraft as by now he felt very light headed and tired. On the ground, the commander had no problem taxiing the aircraft or positioning it on a self-guided stand; he was then beginning to feel better.

When the aircraft had arrived on stand, the first officer stood up, opened the flight deck window and leant out. He did not consider that being on oxygen had made him feel better and began to feel physically better only after he later left the aircraft. However, he still felt as if he was in a daze. The SCA had entered the flight deck after landing and commented that she could see a "slight haze" evident throughout the cabin. The commander completed the Technical Log and told an oncoming engineer that there was a problem with the 'Air'. He then took the first officer to the Terminal where both crew members were met by a nurse before being taken to hospital.

1.2 Injuries to persons

Injuries	Crew	Passengers	Others
Fatal	0	0	0
Serious	0	0	0

Minor/None	5	75	0
------------	---	----	---

1.3 Damage to aircraft

None

1.4 Other damage

None

1.5 Personnel information**1.5.1 Commander:**

Male	Aged 37 years	
Licence:	Airline Transport Pilot's Licence	
Instrument Rating:	28 February 2000	
Base check:	28 February 2000	
Line check:	11 February 2000	
Medical certificate:	Class 1 issued 30 June 2000	
Flying experience:	Total all types:	9,500 hours
	Total on type:	2,900 hours
	Last 90 days:	140 hours
	Last 28 days:	55 hours
Duty time:	On duty at 1000 hrs on 5 November 2000 following a rest period greater than 12 hours	

1.5.2 First officer:

Male	Aged 22 years	
Licence:	Commercial Pilot's Licence	
Instrument rating:	25 April 2000	
Base check:	10 September 2000	
Line check:	31 June 2000	
Medical certificate:	Class 1 issued 11 October 2000	
Flying experience:	Total all types:	1,050 hours
	Total on type:	840 hours
	Last 90 days:	140 hours
	Last 28 days:	45 hours
Duty time:	On duty at 1000 hrs on 5 November 2000 following a rest period greater than 12 hours	

1.6 Aircraft information

1.6.1 General information

Manufacturer:	British Aerospace
Type:	BAe 146-200
Aircraft Serial No:	E2103
Year of manufacture:	1988
Certificate of Registration:	Registered in the UK as G-JEAK. Issued 29 November 1996
Certificate of Airworthiness:	Transport (Passenger) category. Valid at time of the incident
Engines:	4 Honeywell ALF-502R-5 turbofan engines
APU	1 Honeywell GTCP36-150M
Total airframe hours:	1,853 hours
Total airframe landings	1,603 landings.

1.6.2 Weight and balance

The aircraft weight and centre of gravity were within normal limits.

1.6.3 Aircraft description

The BAe 146 aircraft was designed as a short range cantilevered high wing transport aircraft with a swept back T-tail. It is powered by four turbofan engines attached to wing mounted pylons which locate them below, and slightly forward of, the wing leading edge. The aircraft is manufactured mostly from aluminium alloy. The ailerons and elevators are manually controlled using spring and servo tabs whilst the roll spoilers, lift dumpers, rudder, tail mounted airbrakes and flaps are all hydraulically powered. No wing leading edge high lift devices are installed. Anti-icing of the wing and tailplane leading edges is achieved using hot air bled from the engines. The cabin air conditioning and pressurisation system, or environmental control system (ECS), uses air bled from the engines and/or the APU, with the maximum cabin pressure differential limited to 0.45 bar (6.5 lb/in²). The two left engines supply ECS pack No 1, the two right engines pack No 2.

G-JEAK is a -200 version of the BAe 146 and is configured for two flight crew, 2 or 3 cabin crew and up to 109 passengers. The Avro RJ aircraft was a later development of the BAe 146 and uses Honeywell ALF-507 engines.

1.6.4 Engine description

1.6.4.1 General, Figures 1 and 2

The engines fitted to the BAe 146-200 are ALF 502R-5 turbofans, each rated at 31.0 kN (6,970 lb static thrust) and these are high by-pass engines with a by-pass ratio of 5.6:1. The engine is configured with two concentric shafts and consists of a core 'gas generator' section, based upon the T55 turboshaft engine as installed in the Chinook helicopter, and a free turbine. The gas generator is comprised of a seven-stage axial and a single stage centrifugal compressor driven by a two-stage high pressure turbine. Air delivered from the compressor enters a reverse flow annular type combustion chamber located around the outside of the turbine section. The fan section/low pressure compressor is driven by the two-stage low pressure free turbine via an epicyclic gearbox. The concentric drive shafts are supported by ball or roller bearings, all of which are oil lubricated and contained in compartments located along the centreline of the engine.

1.6.4.2 Oil System

Lubrication of the ALF 502 is provided by oil that is stored in an externally mounted oil tank. The oil flows through a constant displacement oil pump which pressurises it for distribution around the engine. After passing through a filter the oil is split into two flow paths. The first path is used in the fan module to lubricate the planetary gear mesh, No 6 and No 7 bearings, the sun gear and the No 8 bearing. The No 9 bearing is also lubricated by centrifugal action of the spinner; oil in this area also provides an anti-ice function. The oil then passes, by gravity, to the fan gearbox sump and then flows to the accessory gearbox. The other oil path is to the gas generator module which feeds the No 1 bearing, the accessory gear drive, the No 3 and accessory drive bearings, No 2 bearing, No 4 bearing and No 5 bearing. The scavenge oil passes a metal chip detector, and is returned to the oil tank via a fuel-oil heat exchanger.

The engine design does not use labyrinth seal technology to contain oil and control internal airflow. Currently, hydopad seal technology is being introduced but, at the time of the incident, the seals were of an earlier design of carbon face seal that were lubricated and cooled by the oil within the various bearing compartments. Any oil escaping from such a seal, particularly at the No 1 bearing position, is likely to find its way into the main engine gas stream, Figure 2.

1.6.5 APU system description, Figure 3

The APU fitted to the BAe 146 is a small gas turbine engine, which provides a source of electrical power and bleed air. The APU operates by taking in ambient air through an intake plenum chamber, which feeds the air to the centrifugal compressor. The air is then compressed and some of this air is then bled off for the pneumatic system. The remainder is fed to the combustion chamber where it is mixed with fuel and ignited. The exhaust gases then drive a radial inward-flow turbine which powers the compressor, accessory drive and output drive shafts.

To obtain a speed suitable for the accessories and the electrical generator, a reduction gearbox is employed. The output of the gearbox has mountings for the electrical generator, the generator cooling fan, fuel control unit and starter motor. The generator cooling fan is mounted on a pad and employs an oil seal on the face of the mounting. Leakage of oil past this seal, which has been known to occur in service, can enter the APU air inlet plenum chamber and be drawn into the engine.

Pressurised (hot) air is taken from the APU and is controlled by an APU bleed valve whenever the APU is running and the APU bleed air is ON. This air is supplied to the pneumatic system via non return valves.

1.6.6 Pneumatic system description, Figure 4

Bleed air for the ECS is taken from the air aft of the high pressure (HP) compressor stage of the engine, via metered orifices, in the combustor section outer wall. This HP air is then passed through a pressure reducing and shut off valve, which controls the pressure to 41 psi, to a pre-cooler heat exchanger. Fan air from the first stage of the engine is ducted over the pre-cooler to provide the cooling air for the HP air. This pre-cooled air, at about 230°C, is then fed to the various systems, such as the ECS and anti-ice systems.

1.6.7 ECS description, Figures 5 and 6

The BAe 146 is fitted with two air conditioning 'packs', mounted in the rear fuselage, which supply pressurised and conditioned air to the aircraft cabin. The packs are supplied with (hot) bleed air from the engines with additional air re-circulated from the cabin. The air to the left pack is from engines Nos 1 and 2 and to the right pack from engines Nos 3 and 4. APU air also supplies the packs when engine bleed air is not available. In each pack the supplied air is flow controlled by a valve, before being fed through the primary heat exchanger, which uses ram air (in flight) for cooling. The cooled bleed air is then fed into the compressor stage of the air cycle machine, after which it passes through the secondary heat exchanger. To remove any water in this air, it is fed through a condenser, where it is cooled again by the conditioned air from the pack outlet. A water extractor removes the water

before the air is finally expanded, and cooled further, in the turbine section of the air cycle machine. To obtain the desired cabin temperature, a temperature control valve injects a controlled volume of hot air, taken from immediately downstream of the flow control valve and, together with air cycle machine bypassed air, taken from downstream of the primary heat exchanger, mixes it with the cold turbine outlet air.

The outlet air from both air conditioning packs is directed to a cabin and flight deck distribution system. The air passes through sound absorbing ducting to a common point, where the left and right pack air is mixed. Air for the flight deck, however, is tapped off from the left pack sound absorbing duct only, and fed direct to the flight deck distribution ducting. The mixed cabin air is then routed to each side of the aircraft, through additional sound absorbing ducts, to ducting connected to the sidewall outlets in the cabin.

1.7 Meteorological information

At the aircraft cruise level of FL240, the wind was from 300°M at 30 kt and the outside air temperature was -38°C.

The recorded weather at Birmingham airport at the time of landing was as follows:

'1420 Hrs: Surface wind 120°M/13kt; drizzle; visibility greater than 10 Km; scattered cloud at 2000 feet AGL; broken at 4000 feet AGL; air temperature +8°C; dew point +6°C; QNH 993 Mb; recent rain.

'1450 hrs: Surface wind 110°M/13kt; rain; visibility greater than 10 Km; scattered cloud at 2200 feet AGL; broken at 2800 feet AGL; overcast at 4000 feet AGL; air temperature +8°C; dew point +6°C; QNH 992 Mb.'

The commander reported that he became visual with the runway in the descent when G-JEAK was between 1,500 and 1,000 feet AMSL.

1.8 Aids to navigation

Not applicable

1.9 Communications

Normal communication was maintained between the crew of G-JEAK and Birmingham ATC. The crew did not declare an emergency and Birmingham ATC was not aware of any problem with the flight.

1.10 Aerodrome information

Not applicable.

1.11 Flight recorders

The AAIB were not notified of this incident until some five days after the event. The flight recorders were not examined, therefore, as both the FDR and CVR would have been overwritten and data relating to this incident lost.

1.12 Aircraft examination

1.12.1 Engineering activity prior to the event

Prior to this event this aircraft, in common with several others in the same fleet, had been subjected to engineering checks on several occasions due to reports of unusual smells, variously described by flight and cabin crews, of a hot oil, petrol, burning or of an acidic nature. In general, crews had

regarded these events as a nuisance rather than a hazard, although their reactions and reported symptoms had been somewhat varied. Following such reports, maintenance action had often, but not consistently, identified the presence of oil in the bleed air/air conditioning ducting both from the engines and the APU. It had not always been possible to reproduce the reported smells on the ground, or during subsequent flights.

1.12.2 Engineering activity following the event

Following this event on 5 November, both ECS packs on G-JEAK, which included the condenser heat exchangers, were changed. All ducting associated with the ECS system was cleaned and a system of regular inspections was implemented to check for further contamination. Although, initially, there were no further reports of contaminated cabin air on G-JEAK, several days later, on 8 November, 'acid fumes' were reported by cabin staff after takeoff. This smell was also noticeable after the engines had been shutdown, but with the APU air 'ON'. Subsequent investigation found no defect and so the aircraft continued to fly, with no reported problems, until 13 November when the source of further fume reports was traced to the APU. This was subsequently changed.

1.12.3 APU

APU	1 Honeywell GTCP 36-150M
Serial Number	P-314A
Hours Since New	13,526 hours
Hours Since Fit	585 hours
Date Installed	15 August 2000
Date Removed	14 November 2000

The operator sent the APU to the manufacturer's overhaul facility for examination. Initial visual inspection revealed that the cooling fan area was contaminated with oil and dirt. The APU was then subject to a receiving test, during which it was discovered that oil was leaking from the cooling fan seal. The fan was disassembled, repaired and a new seal fitted, following which a full test of the APU was carried out. During this test, no evidence of oil leakage anywhere else on the APU was apparent.

1.12.4 Condenser heat exchangers examination

Examination of the two condenser heat exchangers removed from the G-JEAK ECS packs revealed evidence of semi-hard black deposits in the ducting of both units, and the presence of wet oil in the unit from the No 1 pack.

1.12.5 Oil black/deposit analysis

Samples of the black deposits were analysed, and the findings indicated that these samples were consistent with the specification for Exxon 2380 (now BP Turbine oil 2380). This was the oil used in the engines and APU on G-JEAK, and the black deposits were carbonaceous residue from this oil but almost all of the amine anti-oxidants were absent, which was expected.

Discussions with the analyst who performed the analysis confirmed that the latter findings indicated that the amine anti-oxidants had performed their intended function, ie, protecting the oil from oxidation under high temperature conditions. These anti-oxidants produce nitrous oxides as they break down. Nitrous oxides can combine with moisture to form nitric and nitrous acids, and these can be absorbed directly when inhaled or with carbon particles which have absorbed these acids. When inhaled in sufficient concentration, these acids are highly irritating to the throat and lung tissues. Some of these acids may be neutralized over time by an alkaline reaction within the body tissues, producing nitrate of sodium. While nitrate absorption in sufficient quantities can cause arterial dilation, hypotension, headache, vertigo and the formation of methaemoglobin, these effects do not

occur instantaneously like respiratory irritation can, nor are they caused by brief, low level exposure. However, although the sample did not contain amine anti-oxidants, it was not possible to determine if nitrous oxides were present on G-JEAK during the incident.

The sample also contained trace amounts (<1000 ppm) of short chain-organic acids, octanoic acid and decanoic acid. These are the expected breakdown products of esters that make up the engine turbine oil and are known irritants, although it was also noted that small trace levels of the same acids were found in new engine oil. The symptoms of exposure to these acids by inhalation starts with eye irritation, runny nose and sore/itchy throat. As the exposure time increases then coughing and breathing difficulties can result. However, concentration levels required in inspired air to produce such symptoms have not been defined and it was not possible to assess the concentration levels of contamination on G-JEAK from the samples.

1.13 Medical and pathological information

At the hospital, both crew members had medical tests and remained in hospital for some six hours under observation, but no abnormalities were detected. The tests included a basic analysis of blood samples but, by the time of this examination, it was some three hours after landing. Following the incident, both pilots returned to flying duties and have reportedly suffered no subsequent ill effects.

1.14 Fire

There was no fire.

1.15 Survival aspects

Not applicable.

1.16 Tests and research

During the investigation, a review was carried out of previous investigations and published research papers that have covered 'fumes' in aircraft air supplies. This section contains summaries of those that were considered relevant to the incident with G-JEAK. It also contains summaries of the results of the research and testing carried out on behalf of the CAA and BAE Systems following recommendations made by the AAIB in May 2001 (see Section 4.0).

1.16.1 Swedish Testing

During an investigation into an incident on a BAe 146, SE-DRE, on 12 December 1999 (see Paragraph 1.18.5 for more details), by the Statens Haverikommission (SHK) Board of Accident Investigation, test flights were undertaken with the aircraft, but these were conducted with replacement engines fitted to the aircraft. The tests were intended to prepare an analysis of air from the air conditioning system into the flight deck and cabin during the flight. The flights involved taking various air samples during a similar flight regime to that of the incident flight and were taken during the taxi out prior to take-off, climb, cruise, descent and the taxi in after landing. Several different methods of air sampling were used during the tests.

The results given in the SHK report are reproduced below:

'...The results showed that the concentrations of carbon dioxide, carbon monoxide, hydrocarbons, oil degradation products (such as formaldehyde) and ozone were within stipulated and generally accepted limits respectively. The concentrations of aldehydes, semi-volatile gaseous substances and volatile organic substances were consistently low. There are no limits established by the JAA or FAA for these substances...

...The cabin pressure varied between 740 and 1010 hPa. The lowest oxygen partial pressure that was recorded was 15,2 kPa and the partial pressure for carbon dioxide never exceeded 0,2 kPa. The concentrations of ammonia, carbon monoxide, sulfur dioxide and nitrogen

dioxide never exceeded the lowest detection threshold of the instruments. On two occasions an increased content of nitrous gases (>15 ppm) was measured that could not be explained. The Total concentration of Volatile Organic Compounds (TVOC) was very low during climb, cruise at altitude, and descent. During taxi the concentrations were slightly elevated compared to the lower limit where problems with indoor air quality begin to appear (0.2 mg/m³ toluene equivalents). This general limit is established through comparisons with the so-called Örebro questionnaire. The air quality tests that were taken in other connections during the flights have shown mainly the existence of the isomeric hydrocarbons hexane, heptane, and glycolates. The elevated concentration of TVOC can be due to the ventilation system in the aircraft, especially the position of air intakes and possibly the heating system.

None of the parameters recorded showed results that deviated from generally accepted limits. Some of the TVOC analyses showed, as mentioned, elevated concentrations, but based upon so few measurements, it is not possible to specify a source of the contamination. Also it is not possible to rule out that the elevated NO_x content which was read, was caused by a deficiency in the measurement equipment or cross sensitivity for other gases...'

1.16.2 BAE Systems tests and research

As a result of recommendations made by the AAIB during this investigation, and other BAe 146 incidents, BAE Systems sponsored their own research programme (as did the engine manufacturer). Their programme initially was to look at the toxicology of possible cabin air contaminants, in-flight sampling of air and analysis of contaminant products found on sound absorbing ducting in the air conditioning system.

BAE Systems also undertook an in-flight sampling programme of in-service aircraft in an attempt to establish the concentration levels of various contaminants. The sampling was carried out on 68 revenue flights, on a variety of aircraft types, including the BAe 146. This programme monitored other substances, which included carbon monoxide (CO) and carbon dioxide (CO₂), as well as relative humidity and temperature. On some flights the following was also measured; Nitrogen Dioxide (NO₂), Formaldehyde (HCHO), Sulphur dioxide (SO₂), acetic acid, volatile organic components (VOC) and Formaldehyde. The results of this programme revealed that all the flights monitored had acceptably low concentration levels of the measured parameters. Indeed the levels of CO measured never reached detectable levels of the sensor used.

During investigation into 'smells' on a BAe 146, it was discovered that the four air conditioning sound attenuating ducts in the rear fuselage were contaminated with a black substance and had a distinct odour. Replacement of the ducts cured the smell on the affected aircraft. The contamination on the ducts was swabbed and tested, and the results revealed that it contained used engine oil but fuel, de-icing fluid and new engine oil were not discovered in the sample. There was, however, a negligible amount of hydraulic oil. The engine oil was identified as used Exxon 2380, together with a small amount of Mobil Jet II. The aircraft operator had not used Exxon 2380 since 1997, having replaced it with Mobil Jet II at that time. As a result, a Service Bulletin, ISB 21-156, was issued by the manufacturer to inspect for, and replace, contaminated ducting.

1.16.3 CAA Tests and Research

In response to AAIB recommendations 2000-6 and 2000-7, made in May 2001 (see Section 4), the CAA undertook a sponsored research programme, independent of that carried out by the manufacturer. The programme was in three parts, over two phases:

Phase 1 - A toxicological review, by DSTL Porton Down, of the products of pyrolysed oil, determined by test and analysis at DERA Pyestock. (This is the same data that was produced for BAE Systems, above.)

Phase 1 A - A review of the Phase 1 findings, a review of learned papers on the subject and a review of the findings from other research, as well as recent service experience.

Phase 2 - Analysis by DSTL Porton Down of contaminated ducting removed from in-service BAe 146 aircraft.

The conclusions of Phase 1 of the programme included:

'No single component or set of components can be identified which at conceivable concentrations would definitely cause the symptoms reported in cabin air quality incidents'

Although this was the main conclusion, it was also discovered that the pyrolysed oil contained the presence of short-chain organic acids that were capable of causing irritant effects. However, there is no quantitative information available on the concentrations needed in inspired air to produce irritancy.

Phase 1A concentrated on the data from Phase 1, in addition to other events and learned papers. As part of this, the CAA reviewed their MOR database and categorised the incidents as determined by their severity, as follows:

Incapacitation	Unable to perform duties
Partial Incapacitation	Able to perform duties but with great difficulty
Impairment	Able to perform duties with some difficulty and/or making minor mistakes
Slight Impairment	Able to perform duties with little difficulty but with reduced efficiency
Feeling Unwell	Feeling unwell, but no impairment of abilities
Irritation	Irritation, but no impairment of abilities.

The CAA derived a table of occurrences by severity and year, which is shown in Figure 7. The table shows that this incident to G-JEAK was determined to be the only incident that rated 'Incapacitation'. The other serious incident to a BAe 146, SE-DRE, was investigated by the SHK (the Swedish Board of Accident Investigation) and this was categorised as '*Impairment*'. It was clear that the BAe 146 aircraft was not the only aircraft type affected and that the Boeing 757 (B757) had also been similarly affected. Reports of other aircraft types, such as the F100, A320/321, B737 and DHC-8, experiencing 'fumes', although not to the same extent, in the cabin/cockpit air, were also noted. However, none of the events related to the B757 were categorised above '*Impairment*'.

During their research, BAE systems had discovered heavily contaminated ECS sound attenuating ducting. They informed the CAA who then organised Phase 2 of their programme, and conducted additional analysis using this ducting. It was sent to DSTL Porton Down, for test and analysis. Their report concluded that the contamination contained chemicals, which were consistent with the products of pyrolysed engine oil, these included octanoic acid and decanoic acid (amongst other acids), which had also been detected in the samples taken from G-JEAK. Some of these chemicals were identified as being irritants of the respiratory tract and that the odour of the contaminant was similar to pentanoic acid, another known irritant. However, due to lack of information about concentrations needed to induce symptoms, no conclusion on causation could be drawn. Additionally it was not possible to liberate the chemicals from the duct under simulated ECS conditions. TCP and TOCP were detected but were at very low concentrations and well below unacceptable levels set by Health and Safety requirements. The report stated that as oral toxicity estimates for TCP and TOCP are so large to produce OPIDN, it is inconceivable that the TOCP concentrations in pyrolysed oil or found in the duct linings could cause OPIDN in aircraft crew or passengers.

The CAA intend to publish a paper on their findings in the near future.

Notwithstanding the ongoing research activity, and in response to AAIB Safety Recommendation 2001-47 (see Section 4.0), the CAA issued several FODCOMs relating to 'fumes' in the cockpit (see Section 1.18.11). These relate to Incapacitation Procedures, Oxygen masks selected to 100% and UK Public Transport Smoke/Fumes Occurrences. In these documents, Operators are specifically reminded that Operations Manual procedures should, at least, include the necessity to use oxygen

masks at 100% whenever contamination is present or suspected, and the need to establish communications by the appropriate switch selections. Additionally, it is recommended that cabin crew procedures should include monitoring of the flight deck. This has already resulted in a reduction in the severity of such events, as determined by the CAA classification given above.

The CAA reports that they are constantly reviewing the activity being undertaken by the manufacturers to solve this problem. They are also carrying out an evaluation of the JAA requirements for cabin air quality, including JAR-E and JAR-25.

1.16.4 NTSB Special Investigation PB84-917006

Following several fatal accidents which were suspected to have been due to pilot incapacitation, mostly associated with the Mitsubishi MU-2 aircraft, the NTSB undertook a special review relating to the possibility that engine oil fumes entering the cabin might cause pilot incapacitation. The results of this study were published in 1984 in a NTSB special investigation report PB84-917006. This review centred on the Garrett TPE-331 turboprop engines that power the Mitsubishi MU-2. Their hypotheses were that a carbon face seal around the main shaft could fail, and leak oil into the compressor stage of the engine, or that a failure of a knife edge labyrinth air seal could allow oil to leak from the reduction gear box into the compressor. With oil leaking into the compressor, their concerns were that toxic or anaesthetic by-products of engine oil would then enter the cabin from the bleed air system and adversely affect the crew.

The NTSB, in conjunction with other parties, conducted tests which involved using a serviceable TPE-331 engine and taking samples from the bleed-air port. The tests involved:

- Running a new build engine.
- Running the same engine, but with the face seals removed, to give the worst case scenario.
- Injecting warm oil directly into the intake of a running engine.

The bleed air samples were then analysed for toxicity and various potential contaminants, including TCP. The results from the first two tests revealed that there was not a measurable difference in the sampled air quality compared to ambient air. The results from the third test indicated that the turbine oil underwent no change as it passed through the compressor. Also, no toxic compounds in any significant amount were detected.

During the toxicological analysis of the samples it was indicated that:

- 1. There is not a significant load of gases in the bleed air of the TPE331 engine, even with oil ingestion, to constitute a toxic threat*
- 2. Any oil that may get into the bleed air does not undergo a significant degradation*
- 3. There are no detectable quantities of supertoxic materials produced by decomposition of ETO-2380 turbine oil under the test conditions of engine ingestion and CAMI laboratory tests*
- 4. Oil mist of ETO-2380 turbo oil in air, as generated in the laboratory, has no unusual toxic effects on rats or chickens.'*

The last statement above was attributed to an additional study carried out for the NTSB by the FAA, and this was detailed in the FAA report entitled:

'FAA-AM-83-12 "Inhalation toxicology: III. Evaluation of thermal degradation products from aircraft and automobile engine oils, aircraft hydraulic fluid and mineral oil.'

published in 1983.

The FAA conducted tests that exposed rats and chickens to the thermal degradation products of engine oil and other synthetic lubricants. The conclusions of these tests were:

'Based on the results obtained from experiments in the non-flaming mode, it seems that none of the products generate a quantity of any smoke component that is significantly more toxic to the rat than is the quantity of carbon monoxide produced. Therefore it is unlikely that any bleed air contaminant originating from lubricant decomposition in the engine will be more toxic than the CO content - which in the Garrett/NTSB tests was reported to be insignificant.'

As a result of this study the NTSB stated:

It is concluded that the hypothesis concerning subtle pilot incapacitation due to engine oil contamination of the bleed air supply from the TPE-331 engine entering the cabin aircraft environment is completely without validity.

1.17 Organisational and management information.

Not relevant.

1.18 Additional information

1.18.1 Current Regulations

Parts of the JAR requirements relating to cabin air quality are reproduced below.

JAR 25.831(b) and (c) state the following:

'(b) Crew and passenger compartment air must be free from harmful or hazardous concentrations of gases or vapours. In meeting this requirement, the following apply:

(1) Carbon monoxide concentrations in excess of one part in 20,000 parts of air are considered hazardous. For test purposes, any acceptable carbon monoxide detection method may be used.

(2) Carbon dioxide in excess of 3% by volume (sea-level equivalent) is considered hazardous in the case of crew members. Higher concentrations of carbon dioxide may be allowed in crew compartments if appropriate protective breathing equipment is available.

(c) There must be provisions made to ensure that the conditions prescribed in sub-paragraph (b) of this paragraph are met after reasonably probable failures or malfunctioning of the ventilating, heating, pressurisation or other systems and equipment. (See ACJ 25.831 (c).)'

JAR APU-210 states the following:

JAR-APU 210 SAFETY ANALYSIS

It must be shown by analysis that any malfunction or any single or multiple failure leading to any of the following Hazardous APU Effects are not expected to occur at a rate in excess of that defined as Extremely Remote:.....

(e) An unacceptable concentration of toxic products in bleed air.....

JAR-APU 320 BLEED AIR CONTAMINATION

For APUs which provide compressor bleed air, the Applicant must:.....

(a) provide the characteristics of APU generated bleed air contaminants in the APU instructions for installation.....'

With respect to the engine JAR -E510 states:

JAR-E 510 Failure Analysis

'2.2 The following Effects should be regarded as Hazardous:.....

(b) An unacceptable concentration of toxic products being generated in air supplied to the aircraft passenger or crew compartments (see also JAR-E 690(b)(2).....'

JAR-E-690(b) details the testing requirements for bleed air contamination :

'(b) Contamination Tests of Bleed Air for Cabin Pressurisation or Ventilation.

The requirements of this paragraph (b) are applicable where it is desired to declare that compressor bleed air is suitable for direct use in an aircraft cabin pressurisation or ventilation system.

(1) Tests to determine the purity of the air supply shall be made.

(2) An analysis of defects which could affect the purity of the bleed air shall be prepared and where necessary the defects shall be simulated and tests, as agreed by the Authority, shall be made to establish the degree of contamination which is likely to occur. If the defect under consideration is such that the Engine would be shut down immediately, the tests required may be modified accordingly.'

1.18.2 Engine Oils

In the early days of aviation, piston engines used mineral based oils for lubrication but, with the introduction of the turbine engine, there was a need for oils that could withstand the higher temperatures without losing their lubrication capabilities. This led to the development of synthetic oils. The first of these were classed as Type I oils, which were di-ester based and came under the specification MIL-L-7808. In the 1960s, oil was developed further and oils with a polyester base were developed, and classed as Type II oils. These could operate up to 100°F higher than the older Type I oils, had better resistance to coking and had enhanced viscometric properties. These oils were produced to specification MIL-L-23699 (now MIL-PRF-23699). Later, a requirement of the newer turbine engines for oils with enhanced oxidation and thermal stability led to a new development in the Type II oils of which Exxon 2380, Mobil Jet II and, lately, Mobil 291 are commonly used examples.

All synthetic oils contain certain additives to enhance their various properties; one such additive is called Tri-cresyl phosphate (TCP), which provides enhanced anti-wear properties. The problem with TCP is that it is known to be a neurotoxic substance, if ingested orally or absorbed through the skin in large quantities. TCP is a mixture of three isomers, meta, para and ortho. The most toxic ortho isomer (TOCP) is associated with organophosphate-induced delayed neurotoxicity (OPIDN), but research has shown that large concentrations are required to induce symptoms and that these can take between seven to 28 days to appear. In addition research has shown that repeated exposure to engine turbine oil does not result in OPIDN. Most synthetic oils used in aircraft engines contain TCP concentrations of only about 3 %, and one manufacturer stated that the levels of TOCP in their oil is considered to be of such a low level in new engine oil that it is un-measurable

Any new formulation of oil must be shown to conform to specification MIL-PRF-23699. Once a formulation has been approved by the US Navy, which has ownership of the specification, then it is 'locked in'. However, within this specification the US Navy does allow for some leeway in manufacturing tolerances. If the formulation is modified, such as the addition or removal of additives, then a formal process is followed with tests conducted by the US Navy. If the change is deemed minor, then the product name remains the same but this results in a new formulation number in the Qualified Products List (QPL).

1.18.3 Other UK BAe 146 incidents

1.18.3.1 G-JEBD, 9 November 2000

On 9 November the flight crew of a BAe 146, G-JEBD, operated by the same company as G-JEAK, experienced a smell of 'fumes' shortly after takeoff; the rest of the flight was uneventful, although both crew members experienced some mild eye irritation. On turnaround at their destination, the smell returned following air conditioning switch selections, but further switch selections appeared to

solve the problem. However, shortly after takeoff the smell was again present for a short period and later returned during the descent; the 'fumes' were intermittent during the flight and were present on the flight deck and in the forward part of the cabin. After parking on stand, both flight crewmembers experienced headaches and eye irritation. All of the crew were taken to hospital, but subsequent medical test revealed no obvious abnormalities.

1.18.3.2 G-JEAM, 23 November 2000

Another BAe 146, G-JEAM, operated by this airline had experienced fume events in the cabin from mid October 1999, which culminated in an incident on 23 November during a flight from Belfast City Airport to London Gatwick Airport. The aircraft had been fitted with replacement ECS packs and an entry had been made in the Technical Log that '*the APU was not to be used unless in an emergency*'. After takeoff from Belfast, a strong smell of fumes was experienced on the flight deck which lasted for about one minute. Some five minutes later, the Senior Cabin Attendant (SCA) reported that fumes were noticeable in the forward cabin at Row 5, but these disappeared after a short period. The remainder of the flight was uneventful. On take off from Gatwick, the flight crew again experienced a strong smell of fumes on the flight deck but, again, these disappeared after about one minute. However, during the later stages of the cruise the commander (the same commander as on G-JEBD during the incident on 9 November) found it very difficult to concentrate on completing the fuel check and R/T tasks. He reported that his throat was dry, that his eyes felt irritated, that he had a headache and was generally aware that all was not well. The SCA reported that she also had a 'very dry throat and eyes' and the other cabin crewmembers also had headaches. The first officer stated that, although he had also smelt the fumes after the takeoff, he had no such symptoms and felt OK. The commander elected to don his oxygen mask, the first officer did not, since he felt normal and the remainder of the flight was uneventful.

The commander stated that, following the incident, he developed blisters inside his mouth, around his left inner cheek, on the roof of his mouth and left lower rear gum. He also had a tight chest, sore throat and suffered from coughing. The source of the fumes was subsequently traced to the No 3 engine, which was replaced on the following day, the 24 November.

1.18.3.3 G-JEAK, 18 April 2001 (EW/G2001/04/20)

At top of climb, the Master Warning System (MWS) displayed a vibration warning on engine No 3. The vibration indication ranged from 0.6 to top of scale, but all the other engine indications were normal and stable with no corresponding vibration felt through the airframe or throttle levers. The cabin staff then reported thick smoke in the cabin, which then became apparent to the flight crew on the flight deck. Oxygen masks were donned; the number three engine was shut down and an emergency descent made back in to Gatwick. The smoke then started to dissipate and so the crew elected to remove their oxygen masks, as these had made communications difficult. The aircraft landed safely at Gatwick. There were no reports of anyone on-board having suffered any ill effects. The number three engine vibration and smoke was subsequently traced to a failed No 8 bearing.

1.18.3.4 G-JEAY, 14 June 2002 (EW/G2002/06/14)

When the engine bleed air was selected on during the climb out from Edinburgh, the co-pilot noticed a haze on his side of the flight deck which had a distinctive odour. Then he started to feel dizzy and so he donned his oxygen mask. The commander donned his mask, established communications with the first officer, who then declared a PAN, and flew the aircraft back to Edinburgh. The commander did not notice any smell during this event, or suffer any ill effects.

1.18.4 International BAe 146 incidents.

1.18.4.1 VH-NJF, 10 July 1997, ATSB Repot 199702276

Whilst the aircraft was on approach to Melbourne the crew reported the smell of oil fumes. The pilot in command, following the onset of these fumes, had difficulty in concentrating on the operation of the aircraft, and suffered from a loss of situational awareness. He relinquished control to the co-pilot

who continued the approach and landing. A supernumerary pilot on the flight deck advised that he had felt nauseous. As there was no visible smoke or mist present, the crew did not consider it necessary to use their oxygen masks.

Prior to the flight, the aircraft had been released with a deferred defect which related to an oil residue in the number two air conditioning pack. This was traced to a leaking oil seal in the No 4 engine. Following this flight, the crew shut down the No 4 engine bleed system and continued the remaining scheduled flight sectors without incident. The engine was eventually replaced.

Following this event the ATSB issued two safety recommendations:

'The bureau of air safety investigation recommends that:

R990052

The Civil Aviation Safety Authority (of Australia), in conjunction with the aircraft manufacturer, British Aerospace Plc, address deficiencies that permit the entry of fumes into the cockpit and cabin areas of BAe 146 aircraft. These deficiencies should be examined by the regulatory authority as part of its responsibilities for initial certification and continued airworthiness of the BAe 146 aircraft.

R990053

British Aerospace Plc liaise with the engine manufacturer Allied Signal to investigate failures within the engine that result in fumes entering the cockpit and cabin areas of BAe 146 aircraft.'

The responses to these ATSB recommendations are included in Appendix 1 of this report.

1.18.4.2 VH-NJA, 7 August 2001, ATSB Report 200103696

Shortly after takeoff, when the engine bleed air was selected on for the air conditioning system, the cabin staff reported a strong smell of fumes in the passenger cabin. As this smell was also present in the flight deck, the flight crew donned their oxygen masks and the crew then proceeded to identify the source of the fumes, using a contamination source location schedule. It was determined that the source of the contamination was from ECS pack number two, which was then switched off. The fumes reportedly affected two cabin staff and several passengers.

On arrival at their destination, the procedure detailed in BAE Systems Information Service Bulletin (ISB) 21-150 was carried out, with no faults found, a procedure designed to trace the source of such contamination. A subsequent flight with a different crew experienced a similar event, with the flight crew again donning oxygen masks. A subsequent engineering inspection revealed oil contamination in the engine No 3 bleed-air system, and the source of this was traced to a leaking No 1 bearing seal.

1.18.4.3 VH-JJU, 18 July 2001, ATSB Report 200103238

During the take-off roll, the cabin manager became aware of a "smoky, burning smell" coming from an air vent in the region of her crew seat at the L1 door. Initially, the smell was a mild odour but, before the fumes dissipated, there was a rapid onset of a strong smell of fumes for a short period. The cabin manager felt overwhelmed by these fumes, and was on the verge of passing out, when her colleagues became aware of the situation and administered oxygen to her. After 10 minutes, the cabin manager recovered but was unable to resume her normal duties. Subsequent blood tests revealed that she had been exposed to higher than normal levels of carbon monoxide (CO).

Engineering examination of the aircraft revealed a worn No 1 bearing seal in the No 3 engine. However, at that stage of flight when the cabin manager had been overcome, the APU had been supplying the ECS packs and so a definite source of the smell could not be determined. It was surmised that it could either have been prior contamination of the No 2 ECS pack by the No 3 engine oil leak, or that the fumes came from an external source during taxi.

1.18.4.4 VH-NJR, 31 May 2001, ATSB Report 200102467

The aircraft had been operating with the number one ECS pack only selected on, as the number two pack was not to be used due to an intermittent oil contamination problem associated with engine No 4. As the aircraft arrived at its destination and was turning off the runway, the crew became aware of a strong smell of oil but, due to the short taxi distance, the crew did not have time to investigate the source of the contaminated air. During the turnaround, the commander alighted the aircraft in order to breathe fresh air but, after a short time, he suffered a headache, itchy eyes, nausea and a bad taste in his mouth. The same crew then prepared the aircraft for the return sector but, when engine Nos 3 and 4 were started, the commander and the cabin staff felt increasingly unwell and, as a result, the flight was cancelled. The aircraft was inspected in accordance with Service Bulletin ISB 21-150 but this did not reveal any oil contamination. However, following an air test it was found that engine No 4 and the APU were both the source of fumes. These were both replaced.

1.18.5 Incident to BAe 146, SE-DRE, on 12 November 1999

Following a fumes incident on board a Swedish registered BAe 146 in which the crew were affected, the Swedish Board of Accident Investigation (SHK) conducted an investigation into the event. A summary, translated from Swedish, of their investigation follows:

'The crew was to carry out three return flights between Stockholm and Malmo together. The flying time on the route is approximately one hour. During the first flight the purser experienced an unpleasant feeling of fainting. She told the other two cabin crew members about this and they stated that they had experienced something similar. They did not recognise any special odour. The pilots had not noticed anything abnormal.

During the subsequent flight one of the cabin attendants who was placed in the forward part of the cabin experienced an odd pressure in the head, nasal itching and ear pain. The other two colleagues in the cabin also felt discomfort and the feeling of "moon walk" while working. The pilots, who did not notice anything abnormal during the second flight either, discussed whether the problem could possibly be due to some fault within the cabin pressure system.

The third flight the same day was flown by the commander. During the flight, which took place at a cruising altitude of FL280, all three members of the cabin crew experienced similar discomfort as during the preceding two flights, but more pronounced. During the first portion of the flight the pilots did not notice anything abnormal but shortly before they were to leave cruising altitude the commander began to feel a mild dizziness.

During the approach towards Malmo/Sturup airport when the aircraft was descending through FL150 the co-pilot suddenly became nauseous and donned his oxygen mask. Then, after an estimated period of ten seconds, the commander also became very nauseous and immediately donned his oxygen mask. After a few seconds of breathing in the oxygen mask the co-pilot felt better and thereafter had no difficulty in performing his duties. However, the commander felt markedly dizzy and groggy for a couple of minutes. He had difficulty with physiological motor response, simultaneity and in focussing. Finally he handed over the controls to the co-pilot. After having breathed oxygen for a few minutes even the Captain began to feel better and thereafter the pilots were able to accomplish a normal approach and landing on Runway 27 without problems. Subsequent to the incident, the airline performed a trouble shooting of the aircraft, which ascertained a minor external oil leak on engine #2.

An intensive technical investigation has been performed on the aircraft and on engine #2. During engine test in test cell and flight test, air specimens from the bleed air and air-conditioning system have been taken and analysed. The samples have not provided any indication of what/which chemical substances caused the symptoms and no technical fault that can explain the incident has been found.

The Board calls the attention to the fact that the location of the customer bleed port for the air-conditioning system is not optimal on the engine type and that knowledge is lacking concerning modern lubrication oils' characteristics at very high pressure and temperatures and their effect on human. In addition instructions were lacking concerning how crews shall act during flight when suspicion arises about contaminated cabin air. The incident was caused by the pilots becoming temporarily affected by probably polluted cabin air.

Recommendations

The Swedish Civil Aviation Administration is recommended to work in consultation with foreign civil aviation authorities concerned to encourage:

that existing emergency checklists and emergency training programs are complemented regarding immediate steps to be taken when suspicion arises that the cabin air is polluted. The instruction for such occasions shall call for the immediate use of the oxygen mask selected to 100%. (RL 2001:41e R1);

that a plan of action is developed for how crews and aircraft shall be handled directly after landing if an incident with polluted cabin air has occurred (RL 2001:41e R2);

that an international database is established with factual information from flights where suspicion of polluted cabin air exists. (RL 2001:41e R3) and ;

that research efforts are initiated in regards to the characteristics of modern lubricating oils under very high pressure and temperature and their influence on the health of human beings (RL 2001:41e R4)'

The responses of the Swedish Civil Aviation Administration, Aviation Safety Authority to these recommendations are included in Appendix 2 of this report.

1.18.6 Boeing 757 cabin air contamination incidents

The flight crews of several UK registered Boeing 757 aircraft have also experienced unexplained symptoms, typically dizziness and eye-watering, whilst in flight. Some of these events are detailed below.

1.18.6.1 G-BPED, 6 October 1999

During the flight, fumes and a smell of oil was evident in the flight deck and so the flight crew carried out the smoke drill and donned oxygen masks. A PAN call was declared and the aircraft diverted to Paris but, during the diversion, the crew had difficulty explaining the urgency of the situation to air traffic control. After an uneventful landing, a technical investigation revealed an oil leak in the APU compressor gearbox. In addition, the compressor back shroud attachment bolts were loose and this had allowed oil to leak past the shroud into the diffuser and subsequently into the air supply.

1.18.6.2 G-CPEL, 7 November 2000

On the 7 November 2000, two days after the G-JEAK incident, the flight crew of a Boeing 757, G-CPEL, noticed an "oily metallic" smell on the flight deck during an outbound flight from London Heathrow to Copenhagen. The same smell was noticed on the return flight. Towards the end of the flight, on approach to Heathrow, the crew missed numerous ATC calls, which prompted the controller to ask the crew "if everything was all right". In addition, the commander did not reduce aircraft speed to configure the aircraft for landing until reminded by the controller when the aircraft was at 3.7 nm DME (distance measuring equipment). It was only after landing that the crew considered a possible connection between the smell and their performance. When the smell was first detected, the crew had discussed the use of oxygen masks, but concluded that there were no side effects to justify their use.

Subsequently, neither crewmember experienced any further symptoms or adverse effects.

The aircraft was, reportedly, comprehensively checked after this incident, but no defects were identified and it was therefore returned to service. However, four days later, on the 11 November, a strong oily smell was noticed on the flight deck of the same aircraft. The first officer developed a significant headache (which continued after the flight) and he felt unable to concentrate. He considered that he was adversely affected and therefore reported unfit for duty after the flight. The commander, however, considered that he was unaffected and continued his flying duties, on a different aircraft. Subsequent engineering investigation revealed the presence of an oil leak from the APU (GTP 331-200ER). This was therefore changed and no similar defects or effects upon the crews were reported after the aircraft returned to service.

1.18.6.3 G-BIKC, 25 January 2001

Boeing 757, G-BIKC, was refused for service during operations on the 25 January 2001 after a flight crew had noted an open defect in the aircraft Technical Log, related to a strong smell of oil during various flight phases on the previous few sectors. During the first sector, on 25 January 2001, the defect was apparently cleared, but with a request for further report, with suspected intermittent oil seepage from No 1 engine. This was associated with an on-going history of fumes on the flight deck. It was reported that events had occurred on 1 June 2000, 23 December 2000, when left ECS pack was rendered inoperative so that the aircraft could be released for service, and also on 20 January 2001, when both flight crew felt unwell and the left ECS pack was again suspected. On this occasion it was selected off and then isolated for the next flight. Two Rolls Royce RB 211-535 turbofan engines are fitted to this aircraft.

1.18.6.4 G-BMRF, 8 February 2001 (EW/G2001/02/17)

Boeing 757, G-BMRF, experienced an incident on the 8 February 2001 when fumes entered the flight deck and reportedly caused 'dizziness and irritation to eyes'. Smoke had also been seen in the passenger cabin, although the smell was strongest on the flight deck. The flight crew carried out the smoke/fumes removal checklist items and used their oxygen masks for the remainder of the flight. A similar event occurred on 10 February 2001, immediately after departure, when strong oil fumes were experienced on the flight deck and persisted for the remainder of the flight. Following discussion with engineering personnel, the left ECS pack was rendered inoperative for the return sector. However, the symptoms occurred again on 19 February 2001, but the strong smell of oil on this occasion disappeared when the left ECS pack was switched off; the flight was then continued at a lower level. Despite extensive ground running of the engines after this incident, no significant smell could be produced and it was suspected that residual contamination from an earlier APU oil leak had remained in the air conditioning system. However, the problem recurred on the 22 February 2001 when an oily smell was reported to have persisted on the flight deck for the duration the flight, causing nose, and increasing throat, irritation to both pilots.

1.18.6.5 G-BIKL, 9 March 2001

G-BIKL experienced an incident on the 9 March 2001 when a metallic oily smell was noticed on the flight deck. The aircraft was descended from Flight Level (FL) 390 to FL350, in preparation for carrying out the related checklist drill, but the fumes dissipated when the flight deck door was opened. The drill was therefore not actioned. In addition to headaches, both pilots suffered from irritation to their mouths and nasal passages. An oily film was subsequently wiped off the flight deck CRT displays and passed to the operating company's engineering department for analysis.

1.18.6.6 G-BMRD, 26 April 2001 (EW/G2001/04/28)

Shortly after takeoff on a flight from Heathrow to Warsaw, the flight crew noticed an engine oil smell which they described as being "heavy". This cleared as they reached top of the climb but returned during the landing. Both flight crew were left with a metallic taste in the mouth; the commander also experienced a tingling sensation on his lips and a sore throat for several days. The first officer was left with minor eye irritation. Investigation by the airline could not attribute a cause of the oil smell.

1.18.6.7 G-BIKT, 19 May 2001 (EW/G2001/05/20)

In a similar incident, this time on a flight from Prague to Heathrow, a strong oil smell was evident on the flight deck during the initial climb, but this cleared by top of climb. The cabin crew did not report any smell, leaving the crew to suspect that this was from the left ECS system, which supplies the cockpit with conditioned air. The cabin is normally supplied by air mostly from the right ECS pack, the left ECS pack and supplemented by recirculated cabin air. The smell returned during the descent, which caused the first officer to suffer a sore throat. The flight crew donned oxygen masks and declared a PAN for an expeditious landing at Heathrow. Following the incident the fault was traced to oil leakage from the left engine, which was subsequently replaced.

1.18.6.8 G-BMRA, 4 September 2001

During climb the commander noticed a metallic taste coupled with an increasingly strong smell. The left ECS pack was switched off, which cleared the smell and the metallic taste but, in the decent, with both ECS packs re-instated, the commander began to feel light headed and "un-coordinated". The effects were still evident after landing during taxi, with some reported errors of judgement and garbled speech. The first officer had been aware of the smell in the flight and, subsequently, he and the commander did not feel well enough to operate their return sector. Subsequent technical investigation revealed oil on both the No 1 and No 2 engine spinners.

1.18.6.9 G-BMRH, 28 January 2002 (EW/8/132002/01/16)

As the aircraft was being prepared for departure, with the APU running, the flight crew became aware of a strong smell of oil on the flight deck. As a result the APU was shut down and subsequently declared unserviceable for use. The aircraft then departed from Heathrow with the same crew. During the climb, at about 10,000 feet, the strong oil smell returned. The crew began to feel nauseous and so donned their oxygen masks, declared a PAN and returned to Heathrow where an uneventful landing was made. Troubleshooting by the airline revealed problems with both the APU and the left engine, which were subsequently both replaced.

1.18.6.10 G-BIKT, 10 November 2002 (EW/G2002/11/10)

During a flight from Heathrow to Manchester, at about 1,500 feet in the climb, a strong smell of oil entered the flight deck. The crew donned oxygen masks, made a PAN call, and carried out the smoke clearance drill from the quick reference handbook. The aircraft was then flown for an uneventful landing back at Heathrow. Following the event, troubleshooting revealed the source of contaminated air to be the left engine, which was replaced.

1.18.7 Boeing 737 incident - G-MSKB 23 June 2000

A 'fumes' event occurred to Boeing 737-500, G-MSKB, of a different operator to the events described above, on the 23 June 2000. All four cabin crew members reported feeling nauseous following passenger disembarkation, but they did not realise that they had all actually been similarly affected during the descent until the matter was discussed between themselves after the landing. In addition to nausea, they reported feeling light headed and hot, but neither the flight crew nor passengers reportedly suffered any ill effects. The aircraft was reported to have had a history of such events and, despite satisfactory ground tests after this incident, similar symptoms were reported two days later by a different cabin crew when working in the forward galley.

1.18.8 Fokker F100 incidents

1.18.8.1 G-UKFF, 7 April 1996

AAIB Bulletin 9/96 included a report on an incident to a Fokker 100, G-UKFF, on 7 April 1996 when all of the cabin crew reported feeling unwell when the aircraft was at FL085. This appeared to have been due to a 'lack of oxygen and/or adverse fumes'. The commander declared an emergency and the aircraft returned to Stansted with all the crew on oxygen. An engineer, who was present when the

doors were opened, reported that the air in the cabin was extremely hot, stuffy and stale. The crew were taken to hospital for examination where three of them remained on oxygen for a further hour. The commander was advised that the crew had ingested 'something abnormal'. Although the aircraft was subsequently removed from service for engineering checks, no cause of the reported symptoms was found. However, on 10 April, the in-flight supervisor and her companion in the forward galley of this aircraft both reported feeling unwell, but continued with their duties, despite suffering from headaches. Again the aircraft was examined, including being test flown on the same route, but no definite cause was determined. Around the time of this event, a report was received from another operator which drew attention to the potential of a specific cleaning agent, designed to clean toilet bowls, but in one case had apparently been used to clean a galley floor, to cause symptoms like light headedness, headaches and nausea when inhaled. The CAA notified UK Operators at that time (CAA ref. 10A/380/15, dated 2 August 1996) of this potential hazard, as the misuse of this agent was apparently widespread.

1.18.8.2 G-UKFN, 22 June 2000

G-UKFN experienced an event during the cruise and descent on 22 June 2000, when all cabin crewmembers felt unwell, with symptoms of nausea and light-headedness. All cabin crewmembers felt better after using the portable oxygen. No problems were apparent with the cabin pressurisation system, which had an indicated cabin altitude of 8,000 feet.

1.18.8.3 G-UKFC, 22 June 2000

Another F100, G-UKFC, operated by the same airline, also suffered a similar event on the same day in June 2000. Shortly after takeoff, the cabin crew began to feel ill and all cabin crewmembers continued to feel unwell during the climb and cruise. They reported their symptoms after landing and, despite being in the fresh air for some 45 minutes, they felt unable to fly the return sector due to headaches and nausea. However, both pilots were not affected. The previous sector had been completed without incident, although the APU had not been serviceable, and the aircraft had reportedly been hot inside prior to engines start. A diesel powered air starter unit had been running for some 10 minutes prior to engines start for the incident flight, in order to supply cold air for the passengers on board.

1.18.9 BAE Systems activity

BAE Systems began notifying the operators of the BAe 146 about problems with contaminated air, and the possibility of crew incapacitation, in 1999. The first of these was an All Operator Message (AOM) 99/020V, which notified operators of possible incapacitation due to the carriage of dry ice, especially in the galley areas, which can cause high levels of carbon dioxide (CO₂) to build up. One of the recommendations to operators was:

'...In the event of flight or cabin crew experiencing the above symptoms or with any detection of fumes, it is recommended that the flight crew should don oxygen masks and any affected crew members be supplied with emergency oxygen...'

This was followed up by AOM 99/024V, which was also related to an incapacitation incident. The recommendation to operators was similar in this case to that given in the earlier AOM and stated:

'...In the event of flight deck crew experiencing any unusual physical symptoms or with any detection of fumes, it is recommended that they immediately don oxygen masks with regulators set to 100%. Where masks are not full faced, goggles should also be donned...'

Following the incident to G-JEAK, AOM 00/030V was issued by BAE Systems to operators and accompanied a Notice to Aircrew. The AOM detailed reports of smoke and fumes contamination from the air conditioning system and provided guidance in an attempt to avoid possible crew incapacitation. This also included a 'best practice' approach, in the various flight phases, for operators of the BAe 146 and Avro RJ aircraft. The summary of the AOM gave the following guidance:

'If smoke or fumes appear from the air conditioning system, follow the abnormal crew procedure -smoke from air conditioning system- don the oxygen masks

If at any time the crew is unsure as to the air quality they should don oxygen masks.

If at any time one crew member appears to be unwell and uses oxygen, it is recommended that all crewmembers use oxygen as a precaution against any unidentified contaminant. Cabin crew should be encouraged to remind flight crew of this requirement - follow crew resource management (CRM) principles.'

At around the same time, AOM 01/003V was issued. This contained recommendations to operators as to what maintenance action should be carried out following a cabin fumes event and also what scheduled maintenance inspections of the air conditioning systems and engines should be conducted.

AOM 01/004V was also issued at this time to notify changes to the emergency checklist items, which had been amended to require the crew to use oxygen when the presence of unusual smells or fumes are detected.

In November 2000, BAE Systems issued Service Information Leaflet (SIL) 21-45, which consolidated all the information from various sources into one document. This detailed document included information on troubleshooting cabin air contamination events, possible sources of such contamination, crew medical testing, on-going maintenance, cleaning procedures and modifications. It also included a questionnaire for operators so that information on these events could be collated.

In March 2001, BAE Systems issued Inspection Service Bulletin (ISB) 21-150, and this was mandated by the CAA (AD 002-03-2001). It contained detailed instructions concerning the inspection for contaminants in the ECS and, should any be found, required inspection of the engines and APU for any signs of oil leakage. Operators were required to accomplish the tasks whenever a cabin air quality problem was identified. This was required at every A check or within 500 flights, and then to repeat these tasks every 500 flights. The ISB also required feedback of the results to BAE Systems for analysis.

After ISB 21-150 was issued, the manufacturer experienced a poor response from operators, with only about a quarter of the expected reports being returned. This was despite the CAA having mandated the requirement for such feedback. The lack of feedback made it difficult for the manufacturer to assess the impact of the ISB and to direct research into the appropriate areas. However, of the results received, all but one of those from scheduled inspections did not reveal evidence of contamination.

The majority aircraft which had experienced a cabin air contamination problem, were associated with oil leakage from the No 1 and/or No 9 bearings in an engine. Some events were related to the APU generator cooling fan, or other areas of the APU, with no faults being found in other cases. During the cabin air quality events reported as part of ISB 21-150, there were no instances where the crew had suffered any adverse physical effects.

In November 2002, after the discovery that some aircraft were found to have heavily contaminated sound absorbing ducting within the ECS, BAE Systems issued ISB 21-156. The ISB was also mandated by the CAA (AD 003-10-2002) and required operators to accomplish the tasks at the next A check or 500 flights and then to repeat the task every C check. Operators were also reminded that if a persistent air quality problem is reported which is suspected of being caused by oil leakage into the bleed air system, then all four sound absorbing ducts in the ECS distribution system should be inspected for signs of contamination. This is defined as:

'Oil contamination in a liquid or paste form, surface coverage which can easily be transferred to a spatula, whilst squeezing the duct any liquid oil seeping through the inner surface, and any strong odour of oil, sweaty socks, locker rooms or rancid cheese, which may indicate breakdown oil products. If contamination is found then ISB 21-150 is required to also be carried out to identify the source of the contamination'.

There was also a requirement to feed the results of the inspection back to the Manufacturer.

In December 2002, APU bay sealing improvements were made under SB 49-36-36019E which was mandated by the CAA under AD 07-04-2003. This introduced improved flexible inlet ducts to reduce the occurrence of contaminants, such as oil leakage from a failed APU cooling fan seal, and exhaust gas, finding their way into the APU air inlet.

BAE Systems are still working with the engine manufacturer to improve the sealing of the engine bearings, especially around the No 1 and No 9 bearing packages. These improvements are being implemented and will reduce the possibility of oil from these areas entering the bleed air supply in the engine. Improvements are also being made to the APU to prevent the ingestion of APU bay contaminants and exhaust gases. Improvements have already been made to the APU generator cooling fan seals and seal runner.

1.18.10 B757 Industry Activity

In May 2001, the AAIB issued five Safety Recommendations (see Section 4.0), one of which was addressed to the Federal Aviation Administration (FAA) and which concerned the B757. It recommended that the FAA work in conjunction with Boeing to take steps to avoid contamination of the air supply from the engines and APU by oil or any other potentially hazardous substance

In its response to this recommendation, the FAA provided the following details of the activities taken by Boeing and the B757 operators.

'...The team concluded that the root cause of the flight deck odor problem is oil leakage from the Rolls Royce RB211-535C engine. The Auxiliary Power Unit (APU) although a contributor to some flight deck odor events, has been found to be a negligible contributor to the flight deck odor issue for the RB211-535C powered 757-200...'

'...Rolls Royce examined a recently overhauled engine... They performed a dye test, and engine tear down and an analysis of all engine leak sources. Rolls-Royce identified specific overhaul improvements for the engine. Rolls-Royce did not identify any specific design changes that would further reduce oil leakage. While these improvements have not been 100% successful in eliminating leakage, they are consistent with the best practices used on all Rolls-Royce engines and have been incorporated into the appropriate engine shop manuals...'

'...Another outcome of the investigation by the team was the recognition that over-servicing of oil for the RB211-535C engines contributes to the flight deck odor issue. (The operator) has instituted emphasis and corrective measures to eliminate oil over-servicing as a contributor to the flight deck odor problem. Boeing has updated the oil servicing procedure in the 757 aircraft maintenance manual...'

In addition, Boeing investigated the use of a Volatile Organic Carbon (VOC) converter in the pneumatic system, with a view to eliminating oil fumes. The tests revealed that hydrocarbons were reduced but only with an efficiency of 30-50%. Also, concerns about the effective life of the VOC converter have precluded its introduction into service at this time.

1.18.11 CAA communications

In December 2000, the CAA issued a Flight Operations Department Communication (FODCOM), number 17/2000, Appendix 3, which addressed *'Incapacitation Procedures'*. It highlights the possibility of smoke or fumes entering the aircraft and the potential for crew incapacitation. Extracts from the guidance provided for flight and cabin crews, as part of the incapacitation drills, are reproduced below:

'3.2.1 The first action in the event of smoke or fumes in the flight deck should be for the flight crew to don oxygen masks and establish communications'

'3.2.3 If during line flying it appears that both pilots are suffering from some form of incapacitation or that one pilot appears to be in any way incapacitated for no obvious reason, then the flight crew should don oxygen masks without delay'

Emphasis was also put on the use of oxygen masks whilst conducting Incapacitation Procedures training.

After the issue of the AAIB recommendations in 2001, the CAA issued FODCOM 14/01, Appendix 4, on 24 August 2001. This again emphasised the use of 100% oxygen whenever contamination of the air is determined or suspected, and that Operations Manual procedures should contain detailed instructions to crews on incapacitation drills. Additionally it was stated:

'Operators should also ensure that incapacitation procedures are regularly practised during recurrent training and that case based studies are discussed at joint flight deck/cabin crews safety training.'

As a follow up to their research, the CAA issued another FODCOM, 21/2002, on 29 August 2002, Appendix 5, entitled *'UK public transport smoke/fume occurrences'*. This detailed 263 events, on four selected types of aircraft, of smoke/fume events in the UK between 1990 and 2001. Of these, 25% were associated with crew or passenger discomfort; two aircraft types were associated with flight crew incapacitation.

Additionally the FODCOM states:

'...the CAA is sponsoring research activity that investigates contamination products from engine oil that could represent a hazard to flight deck crew...'

A further recommendation was made to operators in addition to those mentioned in the previous two FODCOMs:

'Operators should ensure that flight crews are aware that the first action in the event of smoke or fumes in the flight deck should be for the flight crew to don oxygen masks and establish communications'

Operators should ensure that flight and cabin crew are advised as to the post-flight actions required following a smoke/fumes incident. These actions should include:

- a) A commanders review of the in-flight incident. This should include consultation with the flight and cabin crew;*
- b) A determination as to whether any crew member felt unwell, or whether their performance was adversely affected.*
- c) The requirement for a crew member who felt unwell, or felt their performance was affected, not to operate as a member of the crew until he/she has been assessed as fit by a medical practitioner and the crew member feels fit to operate.*

The instructions to flight and cabin crew should be detailed in the operations manual.'

1.18.12 House of Lords Select Committee on Science and Technology

In its report, issued in 2000, the House of Lords select committee on Science and Technology had reached the following findings relating to cabin air contaminants:

1.69 Under normal operating conditions, volatile organic compounds in cabin air were found to be either undetectable or at very low levels of up to 3 parts per million (ppm) - of which the majority (80%) were alcohol from alcoholic drinks. These levels are far below the 1,000 ppm total workplace limit and below the workplace limit for any single component. We thus conclude that cabin atmosphere levels of volatile organic compounds present no risk to cabin occupants under normal operating conditions.

1.72 The absence of confirmed cases of tri-ortho-cresyl phosphate (TOCP) poisoning from cabin air and the very low levels of TOCP that would be found in even the highly unlikely worst case of contamination from oil leaking into the air supply lead us to conclude that the

concerns about significant risk to the health of airline passengers and crew are not substantiated.'

1.18.13 Additional reports and comments

The following information is taken from published reports, which have explored the issue of fumes in aircraft cabin air supplies.

Following several incidents of smoke and fumes on board BAe 146 aircraft in Canada, a research programme was undertaken. The findings were reported upon in the document:

'Air quality and health effects associated with the operation of BAe 146-200 aircraft. Applied Occupational and Environmental Hygiene. 13(10)733-739(1998) C. Van. Netten'

The testing carried out involved taking air samples on various aircraft that had suffered from cabin air quality events. All the aircraft tested were the BAe 146, except for one aircraft that was used for comparison purposes, which was a Dash 8-100. The first aircraft to be tested had had an event on the flight prior to the test flight, following complaints by the flight crew; the oil in the engines was changed to a different brand of oil prior to the test flight during which air samples were taken. The second aircraft had suffered from a cabin air quality problem that required the crew to rest for 24 hours. This aircraft was returned to its departure point and tested on the ground. A third aircraft, with a 'normal' air conditioning system, had air sampled during a three hour flight, and a fourth aircraft, modified with an activated charcoal air filter, had air sampled during a four hour flight. The air on the Dash 8-100 was sampled during a three hour test flight.

The conclusion in the report was:

'...Although cresyl phosphates are present in engine oils, these were not found in the cabin air of problem aircraft. The air quality of normal BAe 146 aircraft compared favourably with that of a Dash-8 not associated with problems...'

In the report the author also stated the following:

'...Some of the reported symptoms appeared consistent with those associated with low level carbon monoxide exposure, including headaches, nausea, light-headedness, and disorientation¹. Some of the other symptoms, including burning eyes, burning throat, watery eyes, and sinus congestion, appeared more consistent with exposure to an irritant such as smoke or Volatile Organic Compounds (VOCs). The tingling and numbness experienced by some individuals appear to indicate some neurological involvement, indicating possible exposure to volatile neurotoxic hydrocarbons such as hexane and octane, as well as tricresyl phosphates (TCPs), known ingredients of engine oils...'

In 1999, the Australian Senate Rural and Regional Affairs and Transport References Committee was tasked to examine air safety, with particular reference to cabin air quality on the BAe 146 aircraft. This committee investigated various submissions on this matter and produced a report entitled:

'Air Safety and Cabin Air Quality in the BAe 146 aircraft'

This report detailed the research and investigations that had been carried out, up to that point, into the subject of the BAe 146 and cabin air quality. Recommendations were made as a result of this inquiry, and these included one requesting that the National Health and Medical Research Council set up and undertake an appropriate research programme on the effect of exposure to aircraft cabin air on aircrew and passengers.

¹ It should be noted that the symptoms of exposure to CO contamination are slow to subside, compared with the reported effects of 'fumes' described in this report.

2. Analysis

The incident involving G-JEAK was an event which highlighted to the UK authorities the possibility that an unidentified substance(s) could enter the air conditioning system of Public Transport aircraft and cause discomfort to, or affect the performance of, flight and cabin crews. During the AAIB investigation of the incident, further incidents involving other aircraft types were reported and, therefore, the scope of the investigation was widened so that these other incidents could also be considered. This involved attempts to identify the structure of any contaminants while also investigating their possible sources.

Although this was always likely to be a long-term project, there were early 'flight safety' actions which were taken to reduce the likelihood of similar events occurring, and procedures put in place to reduce the impact of such events. These early actions took the form of AAIB Safety Recommendations that called for both operational and engineering action. This analysis covers both the short-term actions and the longer-term research.

2.1 The flight

The initial flight made by G-JEAK to Paris was uneventful and the return flight normal, until the SCA informed the commander of the reported "oily, petrol" smell. However, the first officer who went to the location, could not detect any unusual smell. Additionally, there were differing views on any unusual smell from a positioning crew located in the front of the cabin. The commander then made the reasonable decision to continue, but asked the SCA to monitor the situation and advise him of any further indications. The flight continued normally until, when in the descent, the first officer began to feel unwell, after visiting the lavatory. The commander then took sensible actions in calling the SCA to the flight deck and ensuring that the first officer went on to 100% oxygen. However, at this stage, particularly with the previous reports of unusual smells, it would have been prudent for the commander to also don his oxygen mask to minimise the possibility that he might also become affected.

Shortly after, the commander considered that he was being affected and began to feel progressively worse, he had also visited the lavatory prior to the descent, but there were no reports of other crew members or passengers, who might have used the forward toilet, feeling unwell. He subsequently recalled that he was only able to concentrate on one decision and therefore actions were overlooked. Firstly, he did not put on his oxygen mask, secondly, he did not declare an emergency and, finally, the commander of the positioning crew who was qualified on type and who was in the cabin, was not informed of the situation. Whilst the commander of G-JEAK appeared to be coping with the situation, he may not have been thinking logically and it would have been sensible for the SCA to have advised the positioning commander of the apparent problem. However, the location of the aircraft was such that the landing was imminent.

This incident indicated that both flight and cabin crews may not be aware of the insidious nature of contamination of the air supply and its diverse effect on individuals. Other incidents have indicated that crews are not always fully alert to the possibility of air contamination on aircraft and have not always taken the most appropriate action. It is vital that all flight and cabin crew are continually vigilant to the performance of their colleagues and all available resources, including other suitably qualified personnel, should be used if personnel are adversely affected. Following initial information on this incident, the CAA issued FODCOM 17/2000 (Incapacitation Procedures) on 28 December 2000. Subsequently, following AAIB Recommendation No 2001-47, FODCOM 14/2001 was issued (use of 100% oxygen) on 24 August 2001 (see Paragraph 2.3.3). These actions should mitigate the effects of any similar occurrence while research continues to identify contaminants/irritants.

2.2 Technical Investigation

2.2.1 G-JEAK

The post incident engineering investigation revealed that the most probable source of the fumes in the cockpit of this aircraft was oil leakage associated with the APU. This was removed from the aircraft on 14 November 2002 after further reports of fumes in the cockpit/cabin on subsequent sectors. Examination of the APU showed oil leakage at the cooling fan seal at that time and it is known that oil leakage from this seal is able to enter the APU air inlet plenum chamber. This meant that oil could then have found its way through the compressor stage of the APU and into the bleed air supply. The air from the APU supplies both of the ECS packs, which provide conditioned air to the cabin and cockpit. The fact that the smell was evident in the cabin as well as the cockpit showed that, at least, the No 1 pack was probably contaminated by the oil leakage, as this is the only pack to supply air to the flight deck. It was not established why, over the period between 5 November and 13 November, there were no reports of crew members becoming unwell, despite the re-appearance of a smell on 8 November, but this could have been attributable to the cleaning of the ECS ducting carried out after the 5 November event removing a build up of oil within the system.

The oil deposits and black substances which were found on the condenser heat exchangers in both ECS packs, also indicated that oil contamination of the system had taken place and that oil based 'fumes/substances' were the most likely source of the contaminated air in the cabin and cockpit. Any oil entering the APU air path would have been heated and then contaminated the supply to the ECS packs. In addition, any oil which had condensed was likely to have been deposited on the inside of the distribution ducting and heat exchangers. Testing of the samples from the condenser heat exchangers identified the oil as Exxon 2380, used in both the APU and engines on this aircraft.

2.2.2 BAe 146 Engine/APU oil sealing

During the course of the investigation, it became apparent that G-JEAK was not the only BAe 146, or aircraft type, to suffer from fumes contaminating the air supply system, with associated effects suffered by the crew and/or passengers. Also, the reports were not limited to just UK based aircraft but related to operations worldwide.

These reported events all had a common theme; oil contamination of the air supply from either the APU or the engines. Once the source had been identified and removed, the smell would disappear. Oil leakage on the BAe 146 was generally associated with the carbon face seals of the No 1 or No 9 bearings in the engines, or the APU cooling fan seal. Failure or defects within these carbon seals allows oil to enter the main gas stream and hence contaminate the bleed-air offtake. Consideration of the design of the air offtake system on the engines of the BAe 146, where all bleed-air is taken from the output of the HP compressor, raised the possibility that this may have exacerbated the fumes problem, in that the bleed-air temperatures are the highest to be found in the compressor section of the engine. Air is often bled from the intermediate pressure (IP) or low pressure (LP) compressor stages in other engine types, but the absolute temperatures of the air bled from the ALF 502R-5 engines fitted to the BAe 146 are reported to be similar to other engine types. (The engines fitted to the later RJ version of the BAe 146 are designated ALF 507. The majority of reports of crews feeling unwell relate to the ALF 502 standard of engine).

Air supplied to the ECS from the engines and APU on the BAe 146 is isolated from the lubricating oil in these units by the carbon face seals. Although such seals achieve maximum efficiency during 'steady state' operations, they may be less efficient during start, acceleration and deceleration and prior to achieving optimum operating temperature. Improvements in seal design continue and should, in future, minimise the amount of oil leakage into the air system. Nevertheless, technical defects arising on any engine or APU can result in oil entering the cabin air system. Whilst the industry seeks to reduce to a minimum the incidence of such events, there is a general acceptance that fume events will occur, from time to time, on all jet powered transport aircraft.

2.2.3 Design requirements

JAR 25.831 requires that the flight deck and the passenger compartment air must be free from harmful or hazardous concentrations of gases or vapours, including after any reasonably probable failure of the air conditioning, ventilation, pressurisation and other systems. Additionally, JAR APU-210 defines that an unacceptable level of contamination of the bleed air must be extremely remote. In respect of the engines, JAR-E-690, JAR-E-510 and associated advisory material, also consider the subject of contamination of bleed air and specify that an un-acceptable concentration of toxic products generated in the air supplied to the aircraft is regarded as being hazardous. However, the difficulty in interpreting this is in identifying those toxic/irritant products, which could have a physiological effect, and in defining their maximum acceptable quantity or concentrations. As the research carried out to date shows, this is still unknown. This approach to certification places the onus for the delivery of 'clean' air upon the design of the engines, APU and ECS system, and makes it difficult to assess whether such systems produce contamination that is deemed hazardous.

However, there are no regulatory certification requirements directly relating to engine and APU lubricating oils, with respect to ensuring as far as possible that they are free of any constituents that, potentially, could affect the occupants of aircraft should turbine engine oil leak into the bleed air system. It would seem unreasonable to assume that, in the future, turbine engine oil will never leak from an engine to contaminate the cabin air supply of an aircraft, both over short and lengthy periods. The critical aspect of this problem, therefore, is to seek to ensure that engine oils will not degrade into substances which will either harm aircraft occupants or affect the performance of crew members.

Such assurance should include situations when the composition of such oils, or their products, may change under normal or abnormal operating conditions. Whilst certain toxic gases, such as carbon monoxide, cannot be excluded from entering air conditioning systems as a result of thermal degradation and carbonisation of lubrication oils under certain engine or APU failure conditions, efficient air filters, or VOC converters, would appear to be part of the solution to this general problem on turbine powered aircraft. However, before such air conditioning system filters can be assessed for their performance, the nature and concentrations of all hazardous compounds to which they may be exposed needs to be established in order that such filters are effective, and effective over long periods. In considering this subject in response to a safety recommendation made during this investigation, Boeing concluded that the efficiency and life of such VOC converters precluded their introduction into service at this time. Another consideration with the use of filters or converters, is that they could possibly mask the evidence of an oil leak by the removal of the odour normally associated with such events, but fail to remove any contamination which could affect flight crews. It is considered, however, that filtration should only ever be used in conjunction with good maintenance practices/design, in reducing the likelihood of the oil leakage in the first place, and not as a substitute.

As detailed in this report, contamination of the cabin air supply by oil products has occurred from both the APU and the engines, with some regularity, on various aircraft, including the BAe 146. The failures/defects within these units appear not to be in keeping with the intent of the current JAR requirements and so, during this investigation, the following recommendation was made.

'It is recommended that the Civil Aviation Authority, as the Primary Certification Authority for the BAe 146 type, takes early action in conjunction with BAE Systems to require that operators of this type should ensure that the standards of maintenance and modification of the aircraft's air conditioning system, engines and APU are such that air supply contamination by oil from the engines and/or APU, or by any other potentially hazardous substance, is avoided.'

[Safety Recommendation No 2001-4 (made May 2001).]

In response to this recommendation, and other similar recommendations made by the ATSB of Australia and the SHK of Sweden, BAE Systems undertook a program of improvements and issued documentation aimed at improving maintenance standards on the aircraft. This included the issue of Service Bulletins, Service Letters and All Operator Messages. ISB 21-150, which required detailed inspections of the ECS system, engines, and APU for signs of oil contamination or leakage, was

mandated by the CAA in March 2001. Inspection Service Bulletin 21-156 was issued to address contamination of the air conditioning ducting and this has also been mandated by the CAA. Lastly to reduce contaminants entering the APU air inlet, the CAA has recently mandated SB 49-36-36019E, which makes improvements to the APU inlet ducting.

In addition, BAE Systems has been working with the engine manufacturer, Allied Signal/Honeywell, and are in the process of introducing improvements to the engine carbon face seals at the No 1 and No 9 bearing locations. Sundstrand have already issued Service Bulletins to improve the effectiveness of the APU cooling fan seal to obviate oil leakage into the plenum chamber.

Since the introduction of these improvements, the CAA MOR database has indicated a significant reduction in the number of reported events in the cabin or on the flight deck of BAe 146 aircraft.

2.2.4 Other affected aircraft types

At the start of this investigation a similar occurrence occurred on a Boeing 757, G-CPEL, on 7 November 2000. This led the investigation to look at aircraft types, other than the BAe 146, which may have suffered from fume events in the cabin and flight deck. This revealed that the issue of contamination of the bleed air supply was not limited to the BAe 146, but was prevalent on at least one other aircraft type, the Boeing 757. However, other events, with similar crew responses, were reported to a lesser extent on Boeing 737 and Fokker 100 aircraft.

The investigation of these reports concluded that the Boeing 757 was suffering with oil leakage, mostly from the engines but also the APU, which was finding its way into the bleed-air system and thence into the cockpit and cabin air supply. The majority of the events were reported by one UK operator of the Boeing 757. The contamination was causing similar crew responses to those experienced on the BAe 146 and therefore the following recommendation was made in May 2001.

It is recommended that the Federal Aviation Administration, as the Primary Certification Authority for the Boeing 757 type, takes early action in conjunction with Boeing to require that operators of this type should ensure that the standards of maintenance and modification of the aircraft's air conditioning system, engines and APU are such that air supply contamination by oil from the engines and/or APU, or by any other potentially hazardous substance, is avoided.

[Safety Recommendation No 2001-5 (made in May 2001).]

In response to this recommendation FAA, Boeing, Rolls Royce and the affected operator carried out extensive research into the problem. They concluded that the APU was a negligible contributor to the problem, and that the engine was the main source. Rolls Royce undertook a review of the engine overhaul processes and introduced several improvements, all of which have been incorporated into the various servicing manuals. However these have not been 100% successful in removing the sources of contamination. A further study revealed that the operator's servicing of the engines was contributing to the problem, with overfilling of the left engine with oil due to the awkward location of the sight glass on the oil tank. As a result, the operator changed their servicing procedures and Boeing updated the oil servicing procedure in the Maintenance Manual for the Boeing 757 in January 2003.

Since the introduction of these improvements, there has also been a reduction in the frequency of reports on the CAA MOR database of fumes in the cabin of UK registered Boeing 757 aircraft.

2.3 Cabin Air Quality

2.3.1 Sources of contamination

Early in the investigation it became quite apparent that there was little information on the effects of contamination of the aircraft cabin and flight deck air supply from oil/breakdown products. It was also evident that there was a distinct lack of quantitative information available about the thermal decomposition products of engine oil or indeed about the normal composition of engine oils and their additives. This subject has prompted several independent reports and studies, as well as other incident

investigations. The problem of oil contamination of cabin and cockpit air supplies has been known for some years and most of the studies into this problem seem to have concentrated on the presence of carbon monoxide (CO). This was also borne out in the study by the FAA for the NTSB, which concluded:

... it is unlikely that any bleed air contaminant originating from lubricant decomposition in the engine will be more toxic than the CO content...

Although this would lead one to believe that there is minimal toxic substance contained in the breakdown components of turbine engine oil, crews on the aircraft which had known oil leakage were still being affected by a substance in the air. It is known that engine turbine oil contains various additives including Tri-cresyl phosphate (TCP), which is a known neurotoxin. During the study, TCP and TOCP were detected during the Phase 2 testing commissioned by the CAA, but their report concluded that the levels found in pyrolysed oil or the ducting were extremely low. As such, it was stated that it is inconceivable that this would cause toxic effects in aircraft crew or passengers. This view is supported by the House of Lords, who concluded in their select committee report:

1.72 The absence of confirmed cases of tri-ortho-cresyl phosphate (TOCP) poisoning from cabin air and the very low levels of TOCP that would be found in even the highly unlikely worst case of contamination from oil leaking into the air supply lead us to conclude that the concerns about significant risk to the health of airline passengers and crew are not substantiated.

Discussions at a meeting at DSTL Porton Down, on 19 December 2000, which was attended by representatives of BAE Systems, the CAA and the AAIB, confirmed that it would not be possible to identify the related chemical compounds from the symptoms reported, since many chemicals can induce similar symptoms. Indeed, if the chemical(s) causing the symptoms experienced in the aircraft is not known, it is difficult to carry out a quantitative study for that particular substance. The only method would be to test for every substance known to induce similar symptoms, but that would be extremely time consuming and would be limited to only currently known substances.

The crew of G-JEAK had evidently become affected by a substance, related to the air being contaminated by engine oil from the APU or main engines, but this substance remains unknown despite the research carried out to this point in time. There is also a question as to whether the aircraft environment at altitude, with its attendant reduced oxygen and humidity levels, could exacerbate the symptoms experienced by crews.

It became apparent during the investigation that there was a definite lack of information available on the potential contaminants from lubricating oil, and their associated physiological effects, and this was determined to be wholly or in part due to the following:

- i) No comprehensive airborne analytical test programme had thus far been conducted on a particular aircraft which suffered from such an oil 'fumes' incident, where the aircraft remained in the same state as it was when the incident occurred. For example, with the subject (defective seal) engine still installed and with the same type of oil as was being used at the time of the incident.
- ii) No airborne tests of the above type appeared to have been conducted thus far with a standard of analytical sampling equipment capable of identifying all of the potential contaminant compounds which may enter the cabin air from the engines.
- iii) No test data appeared to have been made available from the oil manufacturing companies, which lists all of the compounds which may be released from engine lubricant oils as a result of leakage into air conditioning bleed air from a defective engine or APU oil seal. This includes conditions where such oils and/or their products undergo thermal degradation.
- iv) Many of the potentially harmful compounds which may be produced by such oils apparently have no available or reliable inhalation dose/effects data available.

As a result the following recommendations were made in May 2001:

It is recommended that the Civil Aviation Authority, as the Primary Certification Authority for the BAe 146 type, should as a matter of urgency sponsor a thorough programme of research to establish the full range of contaminant compounds that can enter the flight deck and cabin air supplies of the BAe 146 aircraft when engine or APU lubrication oils leak into the environmental control system.

[Safety Recommendation No 2001-6 (made May 2001).]

It is recommended that the Civil Aviation Authority reviews the types of contaminant compounds identified from the research programme recommended at 2001-6 above, to assess whether any of these compounds could induce adverse physiological and/or neurological effects in the occupants of the BAe 146 or other aircraft types.

[Safety Recommendation No 2001-7 (made May 2001).]

In response to these recommendations the CAA and BAE Systems both undertook their own studies. The CAA concluded that no single component or set of components would definitely cause the symptoms reported. However, short chain organic acids were detected in samples taken from G-JEAK, and in samples of pyrolised oil tested, which can cause irritant effects. BAE systems research concluded that the concentrations of oil mists, vapours and thermal decomposition products in the cabin could be within one order of magnitude capable of causing mild irritancy.

The fact that irritants feature in both sets of research seems to corroborate the analysis made on the oil deposit samples taken from G-JEAK, following the incident, in which the DERA analyst stated that the contamination could have contained nitrous oxides, from the breakdown of the amine anti-oxidants in the oil. Nitrous oxides, when combined with moisture, produce nitric and nitrous acids, substances with an irritant effect. There was not enough evidence to confirm that this had occurred during the incident on G-JEAK, although it remains a possibility. In addition octanoic and decanoic acids, which are also known irritants were present in the samples taken on G-JEAK.

2.3.2 Effect on crew members

Subsequent research and tests suggest that the effects on the crew of G-JEAK, and the crew of other aircraft which suffered similar incidents, could have been exposure to oil related fumes in the cabin air originating from either an engine or the APU which, although not known to be toxic, may well act as an irritant. Irritants may affect people in different ways, due to slight physiological differences and their individual sensitivities to different substances. This may explain why in some reported events, where flight crews are exposed to the same environment, one person is affected more than another.

Taking the G-JEAK incident as a case in point, the first officer was severely affected to the extent that he was unable to continue with his duties but the commander was less affected and was able to fly the aircraft, albeit with some difficulty. This was also the situation on G-JEAM, on 23 November 2000, where the commander was affected with headaches, dry throat and eyes but the first officer was without any symptoms. The incident to SE-DRE on 12 November 1999 also resulted in the captain being affected to a greater degree than the first officer.

The CAA, also in response to the recommendations, reviewed the CAA MOR database to categorise the events into various groups, depending on the severity of the symptoms reported by the crews. These groups were:

- Incapacitation
- Partial incapacitation
- Impairment
- Slight impairment
- Feeling unwell
- Irritancy.

From this, the majority of the incidents were not categorised above 'slight impairment' and most were categorised as 'irritancy'. This showed that, in most cases, the symptoms were not severe enough to cause serious incapacitation or impairment of abilities, but were enough to reduce the efficiency of the crew. This was still considered to be a flight safety issue.

In the Canadian paper, by Mr C. Van Netten, it is stated that:

'the symptoms of headaches, nausea, light-headedness can be associated with carbon monoxide exposure and that burning eyes, burning throat, watery eyes and sinus congestion is associated with exposure to an irritant. These are similar symptoms to those described on many of the incidents in which oil contamination was discovered.'

However, this is a subjective assessment. It has already been stated that one substance is unlikely to be the cause of the many symptoms described by affected crews and similar symptoms can be traced to many potential contaminants, including carbon monoxide. However, it has been determined by the various research programmes that any bleed air contaminant is unlikely to be more toxic than the carbon monoxide content. During the research carried out, which included in-flight monitoring, the levels of CO measured did not ever reach appreciable detectable levels.

What is not explained are the somewhat different symptoms experienced by the first officer in the G-JEAK event, of tingling and shaking. These could possibly be associated with exposure to a neurotoxin, but all of the research so far has not identified a potential source in sufficient concentrations of such contamination to cause these effects. In addition, the commander of G-JEAK did not exhibit these symptoms and the expectation would be for both crew members to be affected by any neurotoxin in a similar manner. Also, such symptoms (including those from exposure to CO), take a relatively long time to both manifest themselves and subside.

Thus, the research carried by the CAA and BAE Systems in response to the safety recommendations, and the symptoms so far reported, tends to indicate that the crews and passengers, including those on G-JEAK, were exposed to an irritant(s) of some kind. The nature of the irritant(s) has not been identified and so the concentration(s) required in inspired air to produce the symptoms experienced could not be established. Research is on-going but, should the irritant(s) not be identified, then, accepting that oil contamination of the air conditioning system will occasionally happen, a way of preventing this irritant(s) affecting flight crews on such occasions seems to be the only near term solution.

2.3.3 Donning of Oxygen Masks

A review of the incidents which have occurred, indicates that not only are operating crews abilities likely to be impaired, to varying degrees, but that they may not be able to judge this for themselves and hence take appropriate remedial action. For example, both flight crew members did not always don oxygen masks when there was an indication of an unusual smell or fumes, or deterioration in performance, or seek assistance from cabin crew members or any other flight crew on board the aircraft. During the incident involving G-JEAK, a positioning crew seated in the passenger cabin were not made aware that one of the operating crew was incapacitated.

On 28 December 2000, the CAA issued Flight Operations Department Communication (FODCOM) 17/2000 which addressed those situations in which smoke or fumes are detected on a flight deck or when one pilot appears to be in any way incapacitated, and required operators to instruct flight deck crew to don oxygen masks as their first action in such circumstances.

The following Safety recommendation was made in May 2001:

'It is recommended that the Civil Aviation Authority should consider issuing additional advice to the crews of jet transport aircraft on the best operational practice when there is a suspicion of flight deck or cabin air contamination. The advice should include the necessity for all flight crew to use oxygen masks selected to 100% and the importance of cabin crew taking an

active part in monitoring the flight crew in such circumstances'.
[Safety Recommendation No. 2001-47 (made May 2001).]

In response to this recommendation the CAA have issued various FODCOM including 14/01, on 24 August 2001, emphasising the use of 100% oxygen and asking for amendments to the operations manual procedures. This was followed up with FODCOM 21/2002, on 29 August 2002, which reiterated the need to don oxygen masks whenever contamination of the air is suspected. Most operations manuals now contain information on the donning of oxygen masks when contamination is suspected.

The research so far indicates that substances acting as an irritant(s) may be the cause of the effects experienced by the flight crew on G-JEAK, and possibly during other incidents. The donning of oxygen masks at the first indication of the problem would have reduced the exposure time to these suspected irritants, reducing their effects, and may have prevented the apparent incapacitation of the first officer and the reduced capacity of the commander to operate normally.

2.3.4 Incidence of 'fume' events following industry activity

Since the activity that has taken place by the oil companies, manufacturers, operators and regulators since the publication of the AAIB recommendations made during this investigation, and those by other investigating agencies, there has been a significant reduction in the number and severity of reported events, on all aircraft types, as indicated by the CAA MOR database.

Whilst cabin air systems are supplied with air using machinery which requires oil lubrication, there will always be a risk, however small, of oil leaking past seals and, subsequently, into the aircraft cabin. This is not limited to those aircraft mentioned in this report, but could affect the majority of aircraft in airline service. Whilst the specific contaminant compounds, that are suspected of causing the reported symptoms, remains unknown, a risk will remain which, at best, could result in flight and cabin crews being distracted and, at worst, render them incapable of carrying out their respective duties.

3. Conclusions

(a) Findings

1. The flight crew of G-JEAK were medically fit and licenced to operate the flight.
2. Fumes were evident in both the cabin and on the flight deck of G-JEAK, indicating contamination of at least the No 1 ECS pack, prior to and after the event, until the replacement of the APU on 14 Nov 2002.
3. The APU on G-JEAK supplied air contaminated with oil to the ECS packs.
4. The oil leakage on G-JEAK was associated with a seal failure on the APU cooling fan mounting plate and this oil found its way into the air inlet plenum chamber, and hence into the bleed-air system.
5. Both ECS pack condenser heat exchangers on G-JEAK were contaminated with black semi-hard deposits and wet oil.
6. The black deposits were analysed and determined to have derived from Exxon 2380 oil, used in both the engines and APU of G-JEAK.
7. G-JEAK was not the only BAe 146 to suffer fume events on the flight deck and in the cabin. Various reports identified other events not only in the UK but worldwide.
8. The majority of investigated events, in which the crew reported symptoms, were associated with contamination of the ECS air supply by oil from either the APU or the main engines.
9. Oil leakage in the engines on the BAe 146 was generally associated with the No 1 and/or No 9 bearing carbon face seals.
10. The regulations JAR 25.831, JAR-APU-210, JAR-E-510 and JAR-E-690, all deal with unacceptable levels of contamination of the bleed air, but do not provide details of toxic contamination that is deemed as unacceptable.
11. The regulations put the onus on the system design for clean air, with little requirement placed on the constituents of the lubricating oils so as not to be harmful to, or affect, the occupants of aircraft.
12. The BAe 146 was not the only aircraft type affected with fumes in the cabin and flight deck. The Boeing 757, Boeing 737 and Fokker 100 all were reported to have had experienced similar events, but with lesser effects on the flight crew.
13. The Boeing 757 has been affected by oil leakage from both the APU and engines, with the majority of affected aircraft fitted with one type of engine.
14. Subsequent investigations of the Boeing 757 incidents, and in response to a safety recommendation, showed that the APU was a negligible contributor and that over-filling of the engine oil tank by maintenance crews was the main contributor to contaminated air.
15. The problem of oil contamination of aircraft cockpit and cabin air supplies has been known about for some years.
16. Early conclusions by previous studies indicated that oil decomposition products are unlikely to be more toxic than the CO content in contaminated air.
17. TCP and TOCP were detected in samples during research, but it was deemed that at the measured levels that it was inconceivable that toxic effects on the occupants of aircraft would result.

18. There was a lack of general information available on potential contaminants of the bleed air by engine oil, and their effects on human physiology.

19 Research by the CAA found that no single or set of components of pyrolysed engine oil would definitely cause the symptoms reported. Short chain organic acids were identified which could cause irritant effects.

20. Research by BAE Systems revealed that concentrations of thermal decomposition products of engine oil in the cabin and flight deck air supply could be within one order of magnitude capable of causing mild irritancy.

21. Samples of oil deposits in the air conditioning taken from G-JEAK led the DERA analyst to state that nitrous oxide would be produced should breakdown of the amine anti-oxidants occur in the oil which, when combined with moisture, forms a substance with irritant affects. However, it could not be established if this had occurred during this incident.

22. Initial conclusions from the research carried out since the incident to G-JEAK, indicate that contaminants in the cabin and flight deck air supply could act as irritants. However, there is not enough information available on the concentrations required to produce the reported irritancy.

23. Symptoms experienced by the crew exposed to fumes on the same flight deck at the same time can be very different.

24. The symptoms experienced on G-JEAK, and in other similar events, suggest exposure to an irritant of some kind. However there is not enough information available at the present time on the likely substances that cause these symptoms.

25. Early donning of oxygen masks can reduce the effects of fumes, whenever they are suspected.

26. The incident involving G-JEAK, and other events, indicated that an irritant(s) can cause degradation in decision making and the reasoning ability of flight crews.

(b) Causal Factors

The following causal factors were concluded during the investigation:

1. There is circumstantial evidence to suggest that the flight crew on G-JEAK were affected by contamination of the air supply, as a result of oil leakage from the APU generator cooling fan seal into the APU air stream, and into the ECS system ducting. This contamination allowed fumes to develop, a proportion of which entered the cabin and cockpit air supply.
2. Subsequent research and tests suggests that the crew of G-JEAK, and the crew of other aircraft which have suffered similar incidents, may have been exposed to turbine engine oil derived fumes in the cabin/cockpit air supply, originating from either an engine or APU, which had an irritant, rather than a toxic, effect.

4. Safety Recommendations

The following safety recommendations were made during the progress of this investigation:

4.1 Safety Recommendation 2001-4 (made May 2001): The Civil Aviation Authority, as the primary certification authority for the BAe 146 type, take early action in conjunction with BAE Systems to require that operators of this type should ensure that the standards of maintenance and modifications of the aircraft's air conditioning system, engines and APU are such that air supply contamination by oil from the engines and/or APU, or by any other potentially hazardous substance, is avoided.

CAA response.

The CAA accepts this recommendation. On 21 March 2001 the CAA declared as mandatory, BAE Systems Service Bulletin 21-150, which reduced the risk of release of oil and/or breakdown products into the occupied areas of the aircraft by introducing specific and periodic inspections for oil leakage, and appropriate corrective actions. In addition BAE Systems, the Type certificate holder, have issued Service Information Letter 21-45 that describes modifications to the BAe 146 air conditioning system, engines and APU, which define an improved standard of aircraft with respect to cabin air quality. These actions are designed to reduce the likelihood of hazardous contamination of the cabin air supply by engines and/or APU. In addition, research is being undertaken into this issue.

4.2 Safety Recommendation 2001-5 (made May 2001): The Federal Aviation Administration, as the primary certification authority for the Boeing 757 type, takes early action in conjunction with Boeing to require that operators of this type should ensure that the standards of maintenance and modification of the aircraft's air conditioning system, engines and APU are such that air supply contamination by oil from the engines and/or APU, or by any other potentially hazardous substance, is avoided.

FAA response:

In a letter, dated July 6, 2001 the Seattle Aircraft Certification Office requested the Boeing Company to provide information regarding possible maintenance action or modifications to the Boeing Model 757 engine, Auxiliary Power Unit, and air conditioning systems to prevent hazardous substances from entering the air supply. Boeing responded to the ACO's request with five different letters:

- a. Boeing letter B-H200-17295-ASI, Dated August 20, 2001
- b. Boeing letter B-H200-17365-ASI, Dated December 20, 2001
- c. Boeing letter B-H200-17420-ASI, Dated April 1, 2002
- d. Boeing letter B-H200-17480-ASI, Dated June 28, 2002
- e. Boeing letter B-H200-17540-ASI, Dated December 13, 2002

The contents of these letters is summarised below:

Boeing indicated that all airplane models occasionally experience some odours or fumes in the flight deck from a variety of sources, but a review of available data indicated that the Model 757-200 with Rolls Royce RB211-535C engines appear to have a higher incidence of events than expected. Most of the 757-200 airplanes with this engine type are operated by a UK operator.

Boeing worked closely with Rolls Royce (the engine supplier), Honeywell (the auxiliary power unit supplier) and the UK engine overhaul company to resolve the issue.

The team concluded that the root cause of the flight deck odour problem is oil leakage from the Rolls Royce RB211-535C engine. The Auxiliary Power Unit (APU), although a contributor to some flight deck odour events, has been found to be a negligible contributor to the flight deck odour issue for the RB211-535C powered 757-200. The same APU is used by the UK operator on their model 767 airplanes with minimal reports of odour problems.

Rolls Royce examined a recently overhauled engine from the operators UK engine overhaul company. They performed a dye test, an engine tear down and an analysis of all engine leak sources. Rolls Royce identified specific overhaul improvements for the engine, and subsequently, these were incorporated into their engine overhaul process. Rolls Royce did not identify any specific design changes that would further reduce oil leakage. While these improvements have not been 100% successful in eliminating leakage, they are consistent with the best practises used on all Rolls Royce engines and have been incorporated into the appropriate engine shop manuals.

Another outcome of the investigation by the team was the recognition that over-servicing of oil for the RB211-535C engine contributes to the flight deck odour issue. The UK operator concerned has instituted emphasis and corrective measures to eliminate oil over servicing as a contributor to the flight deck odor problem. Boeing has updated the oil servicing procedure in the 757 Aircraft Maintenance Manual. The updated procedure was made available in the January 2003 manual revision and the intent of the change was previously communicated to the 757 fleet via the March 2002 fleet team digest.

In addition to the above, crew operating procedures were re-emphasised with UK operator.

Boeing also explored the option of adding a volatile organic carbon (VOC) converter to the bleed air system to reduce or eliminate oil fumes. Flight and laboratory testing indicated that the VOC converter would reduce hydrocarbon levels of the bleed air. However, the observed efficiency is only 30-50% of the total hydrocarbon input. Thus the converter may reduce the oil odor in the airplane but will not eliminate it. Furthermore, the life of the VOC converter is not well defined and may not support successful commercial airplane operation. Due to these issues, installation of VOC converters is not being pursued at this time. Further developments in the technology may allow its use in the future.

With the improved engine overhaul procedures, improved oil servicing procedures and the re-emphasizing of crew oxygen procedures at the UK operator, Boeing believes the intent of the FAA Safety recommendation has been satisfied. They indicate their conclusion is supported by the reduction in incidents reported by the UK operator and that this information was reviewed by the UK CAA in October 2002.

The FAA regarded this as Closed - Acceptable Action.

4.3 Safety Recommendation 2001-6 (made May 2001): The Civil Aviation Authority, as the primary certification authority for the BAe 146 type, should as a matter of urgency sponsor a thorough programme of research to establish the full range of contaminant compounds that can enter the flight deck and cabin air supplies of the BAe 146 aircraft when engine or APU lubrication oils leak into the environmental control system.

CAA Response:

The CAA partially accepts this recommendation. The CAA, as a matter of urgency, is sponsoring a programme into the possible contaminants that can arise in aircraft air conditioning systems as a by-product of pyrolysed engine oil. However, this research is not specifically associated with fumes events on the BAe 146 which is the responsibility of BAE Systems and Honeywell (the Type Certificate (TC) holders for the aircraft, engine and APU), to technically investigate. The CAA programme is generic research with the intent of understanding what contaminants could arise in aircraft of any type and thus be best placed to judge the TC holders proposed actions in the case of the BAe 146, and to determine any similar needs for other aircraft types. In addition, the research findings will allow CAA to determine whether global changes are required in airworthiness standards and provide evidence that would assist any subsequent JAA/FAA requirements harmonisation activity.

4.4 Safety Recommendation 2001-7 (made May 2001): The Civil Aviation Authority reviews the types of contaminant compounds identified from research programme recommended at 2001-6 above,

to assess whether any of these compounds could induce adverse physiological and/or neurological effects in the occupants of the BAe 146 of other aircraft types.

CAA Response:

The CAA partially accepts this recommendation. The determination of whether contaminant compounds from engine, APU or lubrication oils could cause adverse effects on aircraft occupants, demands a specialist knowledge of human toxicology. Such expertise is only available in departments whose personnel have the necessary level of training. The CAA believes that it is therefore appropriate that a review of any potential contaminating compounds should be undertaken by a research department with the required expertise in toxicology, and not the CAA itself.

The CAA will ensure that the recommended review is undertaken by an organisation with appropriate skills and expertise in this area. Specifically, the research programme sponsored by CAA, described in the response to recommendation 2001-6, includes a toxicological review of the compounds it identifies.

4.5 Safety Recommendation 2001-47 (made May 2001): The Civil Aviation Authority should consider issuing additional advice to the crews of jet transport aircraft on the best operational practice when there is suspicion of flight deck or cabin air contamination. The advice should include the necessity for all flight crew to use oxygen masks selected to 100% and the importance of cabin crew taking an active part in monitoring the flight crew in such circumstances.

CAA Response:

The CAA accepts this recommendation. In addition to the guidance contained in FODCOM 17/2000, published 28 December 2000, the CAA will consider issuing additional advice to operators of jet transport aircraft on the best operational practice when there is suspicion of flight deck or cabins air contamination. The CAA will consider expanding on current advice to include the necessity for all flight crew to use oxygen masks selected to 100% and the importance of cabin crew taking an active part in monitoring the flight crew in such circumstances. Target 31 August 2001.

5. Figures and Appendices

Figure 1: Cross Section of the Honey well ALF 502 Engine, showing Gas Flow and Bearing Locations

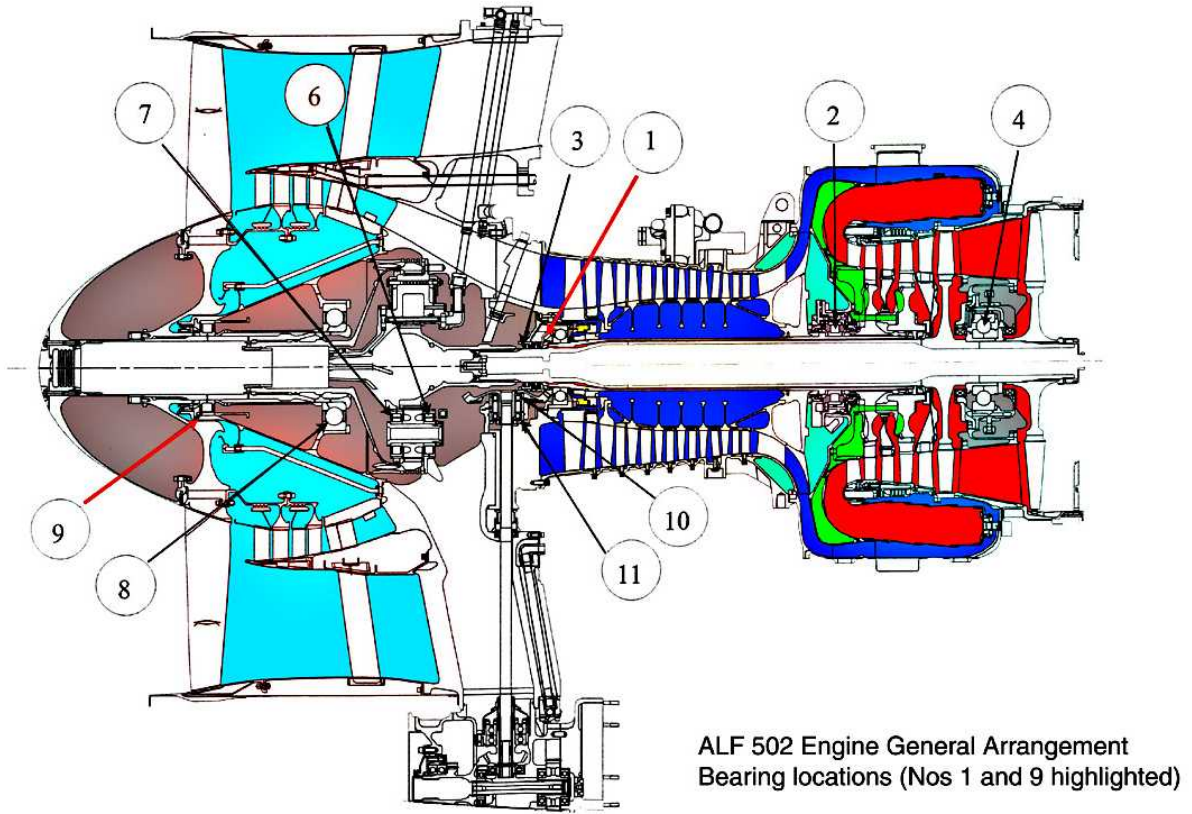
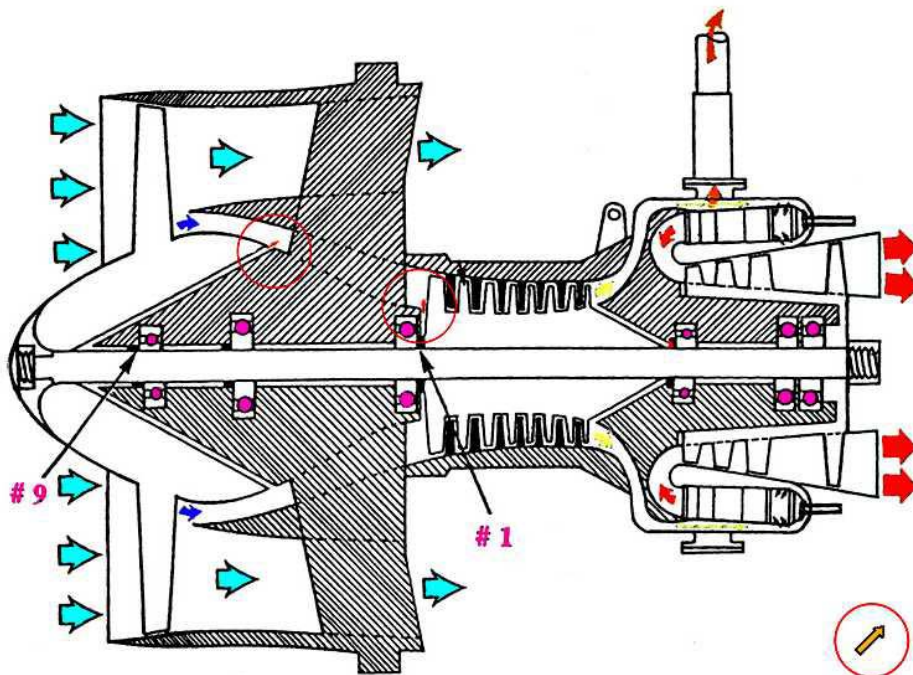

Figure 2: Simplified Image of ALF 502 - Engine showing Bearing Location and Oil Leakage Paths



Simplified image of the ALF 502 engine
Courtesy BAe Systems

Potential oil leakage paths from bearing Nos 1 and 9
seals in to main gas stream

Figure 2

Figure 3: APU Details

APU Details
Cooling fan *

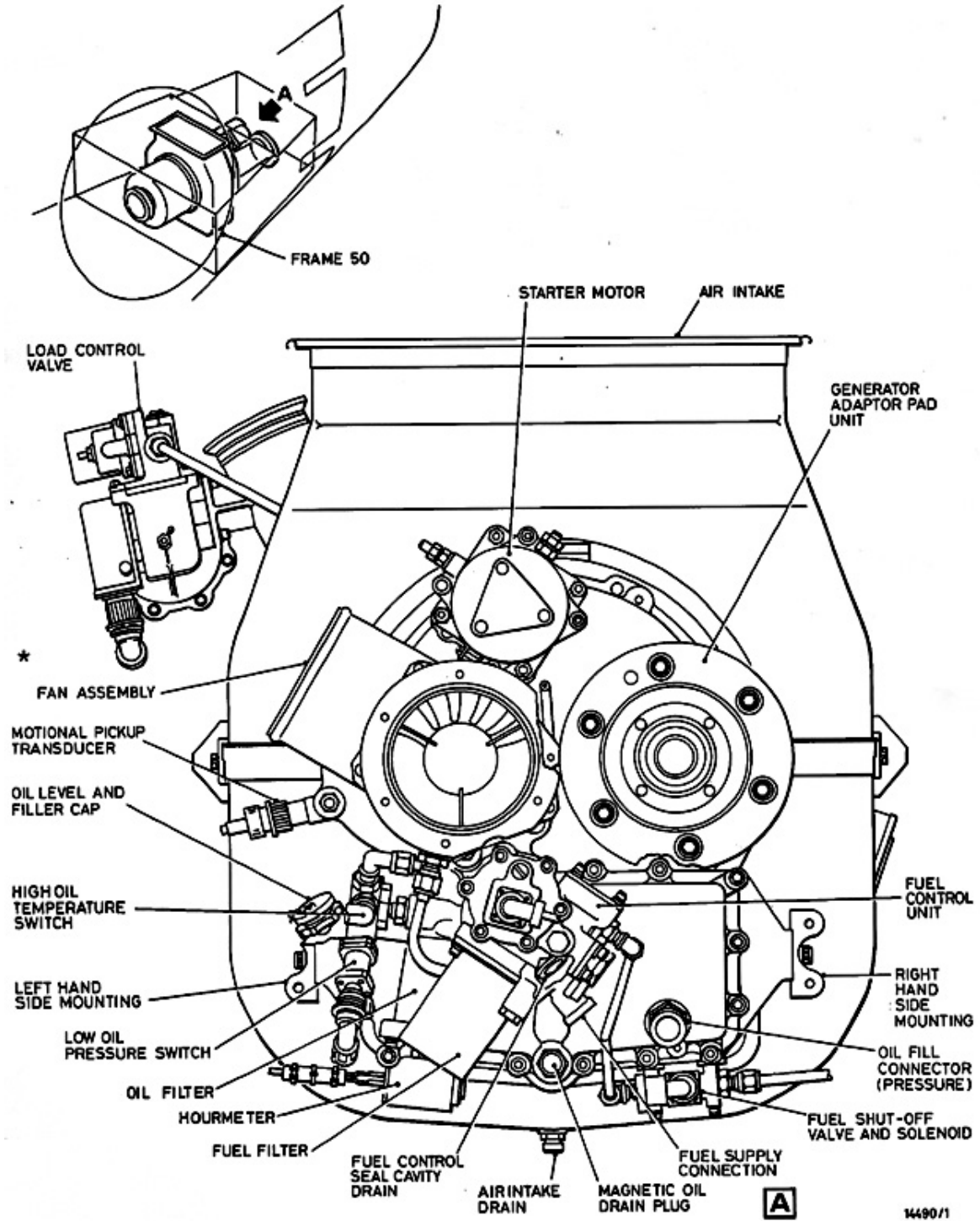

14490/1

Figure 4: Simplified Schematic of BAe 146 Pneumatic Bleed Air System

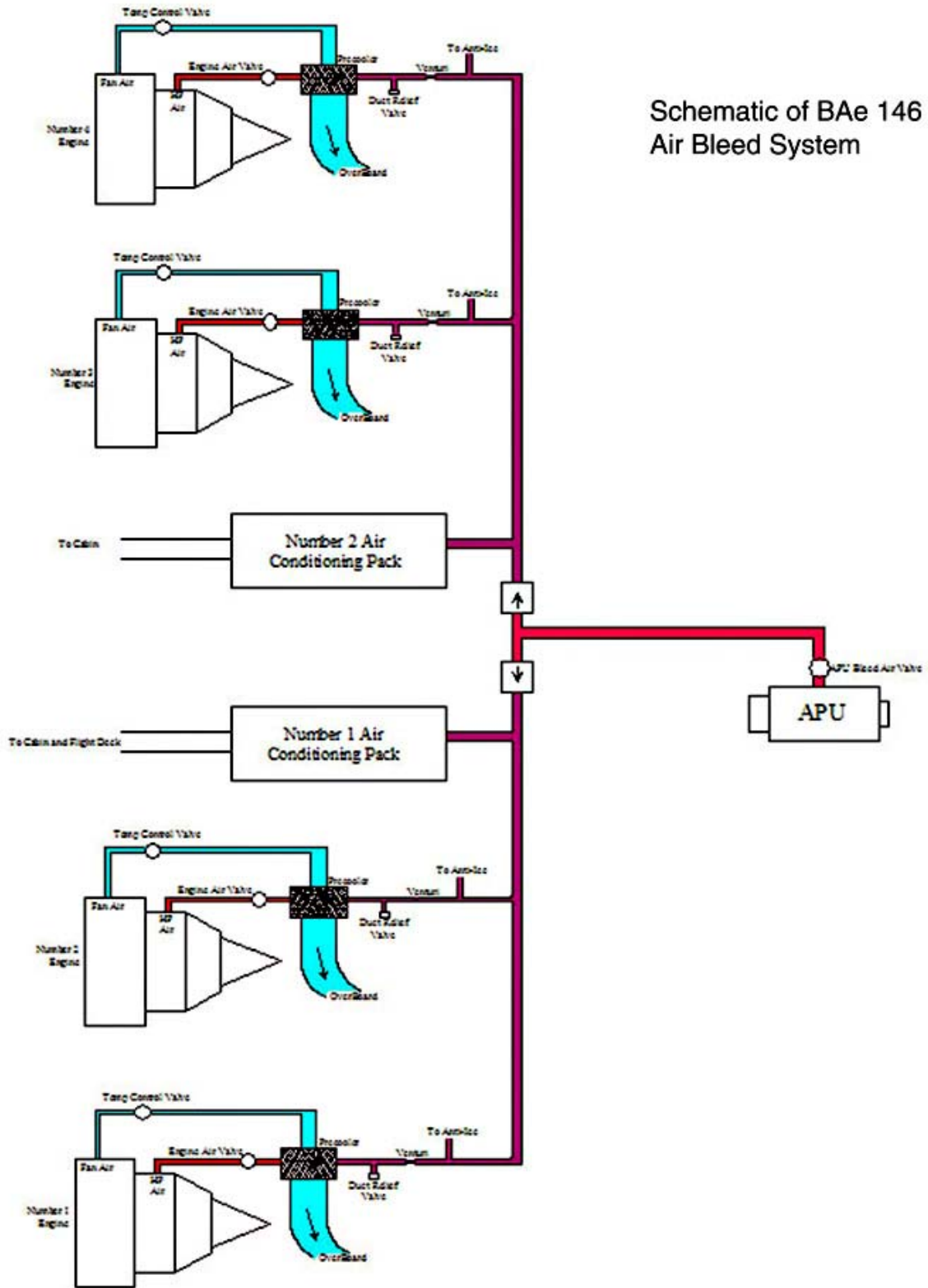
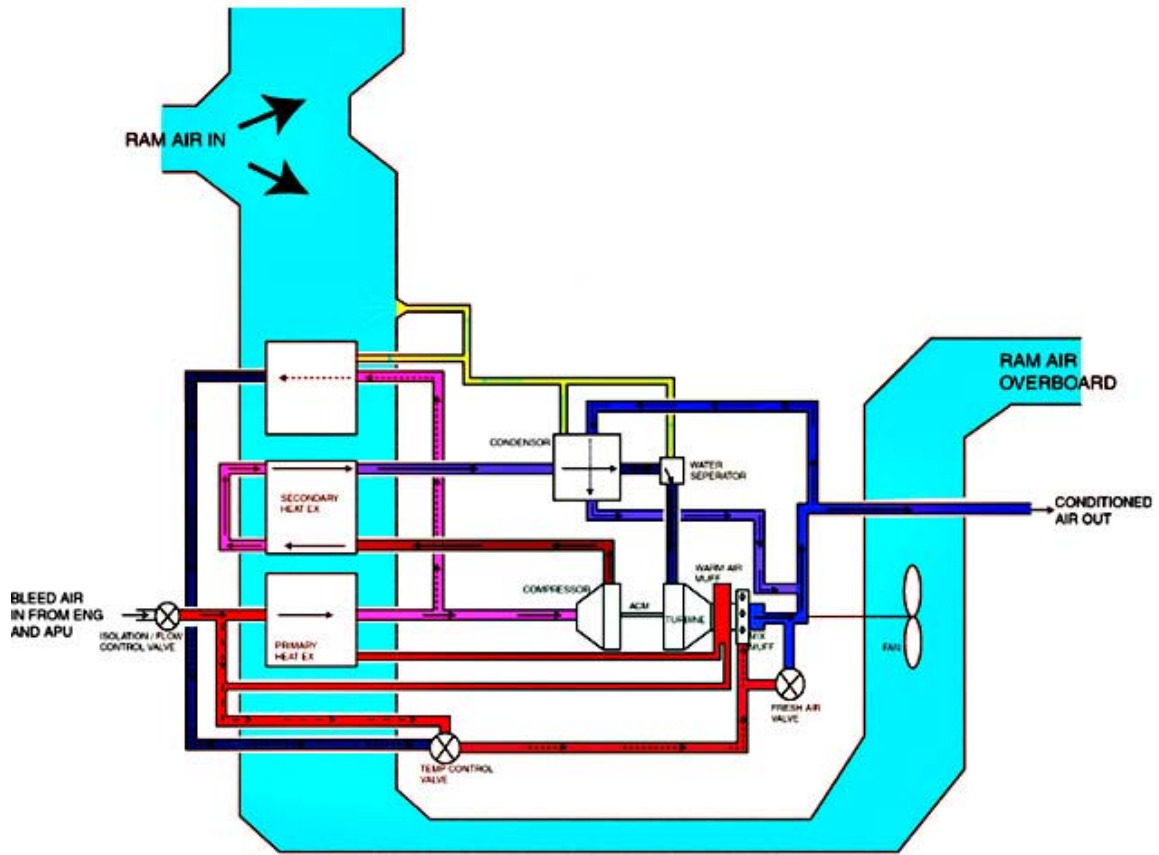
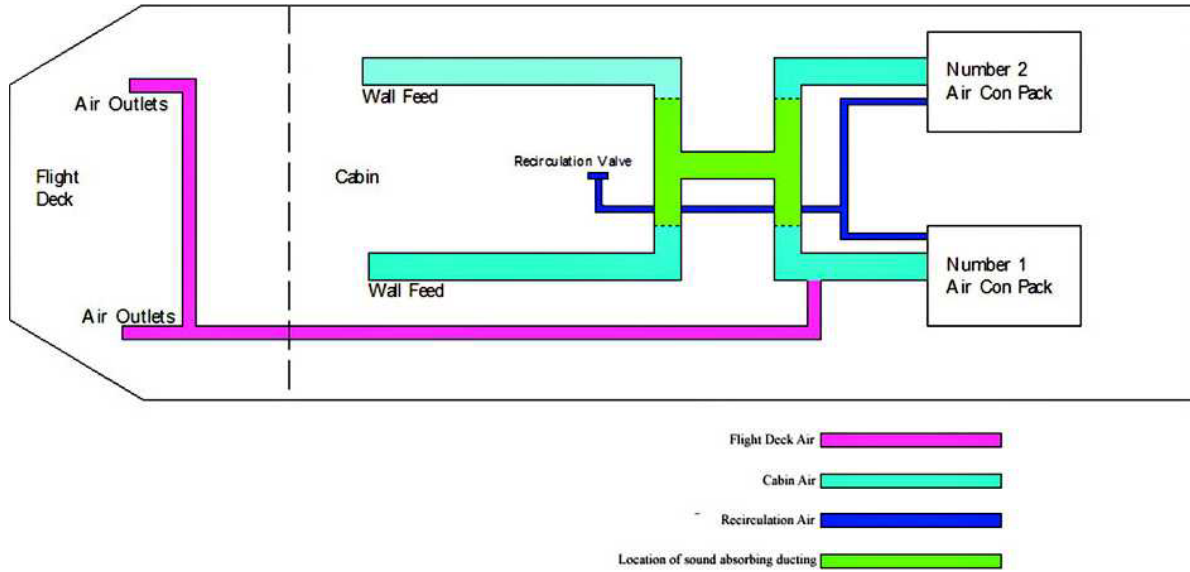

Figure 5: Simplified Schematic of BAe 146 Air Conditioning Pack



Schematic of BAe 146 ECS Pack

Figure 6: Simplified Schematic of BAe 146 Air Distribution System



Schematic of BAe 146 Air Distribution System

Figure 7: CAA Derived Level 1 Flight Deck Occurrences by Year and Severity

Correct as of 14/11/03

**Level 1 Flight Deck Occurrences by Year and Severity
(All Types- From UK MORs)**

Level of Severity (see table 3)	1996	1997	1998	1999	2000	2001	2002	2003
Incapacitation					BAE 146			
Partial Incapacitation		BAE 146		BAE146				
Impairment		BAE 146		BAE146 B757	BAE146 B757	B757		
Slight Impairment				BAE146 B757 B737	BAE146 BAE146 B757 F100	BAE146 BAE146 B757 B757 B757 B737 DHC8	BAE146 BAE146 BAE146 BAE146 B757 B757	
Feeling Unwell	DHC 8 F100 B747	BAE146 B757 A320		BAE146 B757	BAE146 B757	BAE146 BAE146 BAE146 B757 B757 B757 B757 J41 B737	BAE146 BAE146 BAE146 B757 B757	B757 EMB145
Irritation		B757				BAE146 B757 B757 B757 B757 B757 B757 B757	BAE146	B757 B757 A321

Slide 1

Appendix 1: ATSB Safety Recommendations R19990052/3 Responses

This appendix is available separately as a download in PDF from the foot of this page.

Appendix 2: SHK Safety Recommendations Responses

This appendix is available separately as a download in PDF from the foot of this page.

Appendix 3: CAA FODCOM 17/2000

This appendix is available separately as a download in PDF from the foot of this page.

Appendix 4: CAA FODCOM 14/2001

This appendix is available separately as a download in PDF from the foot of this page.

Appendix 5: CAA FODCOM 21/2002

This appendix is available separately as a download in PDF from the foot of this page.