

---

## Crash after takeoff, Boeing 747-2B5F, HL-7451

---

**Micro-summary: Following takeoff, this Boeing 747 lost altitude and crashed.**

---

**Event Date: 1999-12-22 at 1838 UTC**

**Investigative Body: Aircraft Accident Investigation Board (AAIB), United Kingdom**

**Investigative Body's Web Site: <http://www.aaib.dft.gov/uk/>**

**Note: Reprinted by kind permission of the AAIB.**

---

### **Cautions:**

1. Accident reports can be and sometimes are revised. Be sure to consult the investigative agency for the latest version before basing anything significant on content (e.g., thesis, research, etc).
  2. Readers are advised that each report is a glimpse of events at specific points in time. While broad themes permeate the causal events leading up to crashes, and we can learn from those, the specific regulatory and technological environments can and do change. ***Your company's flight operations manual is the final authority as to the safe operation of your aircraft!***
  3. Reports may or may not represent reality. Many many non-scientific factors go into an investigation, including the magnitude of the event, the experience of the investigator, the political climate, relationship with the regulatory authority, technological and recovery capabilities, etc. It is recommended that the reader review all reports analytically. Even a "bad" report can be a very useful launching point for learning.
  4. Contact us before reproducing or redistributing a report from this anthology. Individual countries have very differing views on copyright! We can advise you on the steps to follow.
-

## S2/2000 - Boeing 747-2B5F, HL-7451

### AAIB Special Bulletin No: S2/2000

<b>Aircraft Type and Registration:</b>	Boeing 747-2B5F, HL-7451
<b>No &amp; Type of Engines:</b>	4 Pratt and Whitney JT9D-7Q turbofan engines
<b>Year of Manufacture:</b>	1980
<b>Date &amp; Time (UTC):</b>	22 December 1999 at 1838 hrs
<b>Location:</b>	Hatfield Forest (N 51° 51.385' E 000° 12.988'); 1.9 nm on a bearing of 204° (M) from the centre point of Runway 23/05 at Stansted Airport
<b>Type of Flight:</b>	Public Transport (Cargo)
<b>Persons on Board:</b>	Crew - 4 - Passengers - None
<b>Injuries:</b>	Crew - 4 Fatal - Passengers - N/A (1 crew member was operator's ground engineer)
<b>Nature of Damage:</b>	Aircraft destroyed
<b>Commander's Licence:</b>	Airline Transport Pilot's Licence (Republic of Korea)
<b>Commander's Age:</b>	57 years
<b>Commander's Flying Experience:</b>	13,490 hours (approximately 8,495 hours were on type)  Last 90 days - 208 hours  Last 28 days - 56 hours
<b>Information Source:</b>	AAIB Inspector's Investigation

### History of flight

The aircraft arrived at Stansted Airport at 1505 hrs on 22 December 1999, after a flight from Tashkent, Uzbekistan. Prior to leaving the aircraft, the flight engineer made an entry in the Technical Log to the effect that the commander's Attitude Director Indicator (ADI) was 'unreliable in roll'; he also verbally passed the details to the operator's ground engineer who met the aircraft on arrival. The inbound flight crew then left the aircraft without meeting the outbound crew who were due to operate HL-7451 to Milan (Malpensa) Airport later that day.

During the turnround, some cargo was offloaded and other cargo, which had been transported by road from London, was loaded. The total cargo on board for the sector to Milan was 140,452 lb. The loading was

almost complete when the outbound crew arrived; this crew comprised the commander who was to be the handling pilot, the first officer and flight engineer. The dispatcher went to the cockpit to meet the outbound crew and gave them the navigation logs and weather information for their flight. Prior to engine start, the commander accompanied the load controller through the aircraft to check the security of the cargo, and then checked the loadsheet before signing it and leaving a copy with the load controller. The load sheet copy indicated that the aircraft weight for take-off was 548,352 lb; this included 68,300 lb of fuel. The ground engineer who had met the aircraft on arrival at Stansted boarded the aircraft for the flight to Milan.

At 1727 hrs, the crew called 'Stansted Delivery' on frequency 125.55 MHz for their flight clearance; however, this frequency is only manned when a high number of airport movements are planned. After two unsuccessful attempts to contact ATC on the 'Delivery' frequency, the crew contacted 'Stansted Ground' at 1729 hrs on frequency 121.72 MHz to request start and push back clearance from their position at Stand Alpha 6. They were informed by ATC that they had no details for their flight and were requested to standby. Then, at 1733 hrs the crew were informed that no flight plan had been received and that they should contact their handling agents. The agents submitted the flight plan and the crew of HL-7451, callsign KAL 8509, were advised at 1742 hrs that their clearance was to Malpensa with a Dover 6R departure and a transponder setting of 2230; the crew read back their clearance correctly.

There was then some delay providing a tug for the aircraft and the crew requested push back clearance at 1813 hrs. However, during the push back the tug experienced problems and was unable to complete the manoeuvre; the result was that HL-7451 was left in a position from which it required marshalling onto the taxiway centre-line. The marshalling vehicle was in position by 1823 hrs and KAL 8509 was cleared to taxi at 1825 hrs to 'Hotel November' (holding point for Runway 23) via 'Hotel Lima'. Shortly after, the 'Ground' controller transferred KAL 8509 to 'Tower' on frequency 123.8 MHz.

The crew contacted the 'Tower' at 1835 hrs and were instructed: "After the next landing aircraft on final line up and wait Runway Two Three". Subsequently, at 1836 hrs KAL 8509 was cleared to take-off with a reported surface wind of 190/18 kt. The Tower controller considered that the take-off was normal and, as the aircraft indicated altitude passed 1,400 feet at 1838 hrs, transferred KAL 8509 to 'London Control' on frequency 118.82 MHz. The air assistant, alongside the controller, also watched the take-off and described it as normal; he also watched the aircraft climbing into cloud. No radio calls were heard from the aircraft subsequent to the frequency transfer instruction from 'Stansted Tower'. The ATC personnel in the Tower then saw an explosion to the south of the airport and realised that KAL 8509 had crashed; they immediately implemented their emergency actions. The Aerodrome Fire Service recorded receipt of the alerting action from ATC at 1840 hrs and dispatched all available vehicles and crews to the reported accident position.

Other witnesses heard and saw the aircraft impact the ground. Some reported feeling the shock waves and others reported seeing the aircraft flying much lower than normal. One eyewitness, close to the impact location, reported two fireballs either just before or just after the aircraft crashed. The second fireball was intense and reported as 'Mushroom' shaped. Essex police recorded the first emergency call at 1843 hrs and initiated their emergency response.

## **Weather**

Subsequent to the accident, the Meteorological Office at Bracknell provided an aftercast of the weather situation at 1830 hrs on 22 December 1999. The synoptic situation showed a strong, mild and very moist southwesterly airstream over the area. A Warm Front was lying just to the west of Stansted Airport, moving quickly eastwards. A strong wind warning was in force at the time of the accident. The METARs (Meteorological Actual Reports) for Stansted were as follows:

1820 hrs: Surface wind of 190/16 kt; visibility of 3,100 metres in mist; cloud few at 400 feet agl and scattered at 500 feet agl; temperature 10·C/ dew point 9· C; QNH 1008 hpa.

1850 hrs: Surface wind of 190/17 kt; visibility of 4,200 metres in mist; cloud scattered 500 feet agl, scattered at 600 feet agl and broken at 900 feet agl; temperature 10· C/ dew point 9· C; QNH 1008 hpa.

On the initial call to ATC, the crew of KAL 8509 reported that they had received ATIS information 'Mike' (timed at 1650 hrs). The reported surface wind was 180/17 kt; visibility 5,000 metres; cloud scattered at 500 feet agl and broken at 700 feet agl; temperature 9°C/ dew point 8°C; QNH 1008 hpa.

Other flight crews, who were in the area close to the time of the accident, were contacted to confirm the weather conditions. All stated that the weather was as reported, but some pilots in medium sized aircraft experienced turbulence.

## **Wreckage investigation**

Shortly after the crash, reports were received that debris had been found on the airfield in the vicinity of the runway. An initial search of the runway that evening, and a more comprehensive search of the surrounding areas at first light, revealed many pieces of lightweight material. Examination of the crash site revealed that the impact had resulted in a large fireball capable of carrying many items aloft; when airborne, these items would have been carried back to the north and onto the airfield by the strong Southerly wind.

The Cockpit Voice Recorder (CVR) was found on the evening of the accident just beyond the impact crater.

Examination of the initial impact area and wreckage trail indicated that the aircraft had crashed on a track of approximately 105° M, close to but fortunately clear of some local houses. On impact, the aircraft was assessed to be pitched approximately 40° nose down and banked close to 90° to the left; the speed was high in the region of 250 to 300 kt. Indications are that the aircraft was structurally complete at impact. The impact crater was 43 metres long and 13 metres wide with a maximum depth of 3.5 metres. The wreckage trail extended, in a fan shape towards the east of the impact crater to a distance of approximately 450 metres.

Further examination of the wreckage indicated that all four engines had been developing high power when the aircraft hit the ground and it was possible to confirm that the landing gear was retracted. Examination of the trailing edge flap actuators indicated that the flaps were in the take-off position of 10°; the condition of the limited wreckage recovered from the leading edge flaps was consistent with them having been extended.

The wreckage investigation and recovery is ongoing and has now resulted in the recovery of the Flight Data Recorder (FDR) and some primary flight instruments, including an ADI.

## **Radar recording**

A radar recording was available from the Stansted Watchman radar. Based on the transponder setting of 2230 with mode C selected, the first return was just past the centre-point of the runway indicating an altitude of 660 feet amsl; airport elevation is 348 feet amsl. At the end of the runway, the aircraft was at approximately 1,200 feet amsl. It maintained a track close to the extended runway centre-line before turning to the left. The radar returns cover a period from 1837.46 hrs to 1838.36 hrs; the last return indicated an altitude of 1,060 feet amsl. The maximum altitude achieved was recorded as 2,460 feet amsl and the rate of descent, from the highest point to the last return, exceeded 5,000 feet per minute. Additionally, the ground speed increased after the highest point achieved, with the maximum speed calculated to be 228 kt over the last two radar returns. The southerly wind and the aircraft change in heading from Southwest, through South to East, would have affected the ground speed.

## **Flight Data Recording**

The FDR, a Sundstrand Universal Flight Data Recorder (UFDR) was successfully replayed. It had a recording duration of 25 hours using magnetic tape and amongst the parameters recorded was altitude, heading, pitch attitude, engine power, control wheel position and roll attitude. The roll attitude data was obtained from the No 1 Inertial Navigation Unit (INU). The data covered the period of the accident flight and two other flights; the roll attitude data for the accident flight and the previous flight showed a constant roll attitude of around wings level.

The data showed the aircraft take-off and climb, initially on runway heading. It reached an altitude of 2,150 feet amsl, 37 seconds after take-off, when it commenced a left turn. The pitch attitude then started to decrease and continued to decrease in a continuous turn to the left until the end of the data. The maximum

altitude reached was 2,532 feet amsl, 11 seconds before the end of the data. The data ended 55 seconds after take-off. The final recorded data indicated an altitude of 967 feet amsl, with a pitch attitude of 38° nose down on a heading of 126°M. Throughout the short flight all four engines were developing power at, or close to, the take-off setting of 1.4 EPR.

The CVR, a Sundstrand AV557C was replayed and contained a 30 minute recording of R/T transmissions and sound from an area microphone which included crew conversation. The recording commenced at the time 'Stansted Tower' instructed KAL 8509 to standby for push back clearance and continued to the time of the crash. The speech was a mixture of Korean and English. The investigation benefited from the assistance of a member of the Republic of Korean Civil Aviation Bureau, appointed, by the Korean Accredited Representative to the AAIB investigation, to assist in translating the text and interpreting the nuances of the crew speech.

There was no recording of any departure brief, however, company procedures required this to have been completed prior to pushback. All 4 engine starts were normal and the after start and pre take-off checks were completed without any stated problems. During the taxi, the commander commented on the fact that his DME was displaying 399 nm and the first officer confirmed that he had a similar indication. The commander then asked how they would identify the 1.5 nm DME distance (for the departure SID) and the flight engineer replied that, "now it was working correctly".

Following take-off clearance, the commander called "Rolling" and the flight engineer gave a time check of "37". Standard calls were made during the take-off run. Then, following a call of "positive climb", the landing gear was selected up and the first officer set the IAS as requested by the commander. After the first officer called the altitude as 900 feet, the ADI 'Comparator' buzzer sounded three times. Shortly afterwards, the warning sounded a further two times, coincident with the commander expressing concerns over his DME indication. There was then an input from the first officer about the heading of 158° (SID track to Detling VOR). At the same time, ATC instructed the crew to contact 'London Control' and the 'Comparator' warning sounded again some 9 times. This occurred about 21 seconds before the end of the recording. During this final period, the flight engineer made two calls of "Bank", and the first officer made a radio transmission acknowledging the frequency change.

### **Previous flight**

The three-man crew that had taken over the aircraft at Tashkent, had met the off-going crew and confirmed that the aircraft was serviceable on the previous sector from Seoul. The commander was the handling pilot and he used full power for the take-off from Runway 08 Left at Tashkent, where the departure required a right turn at 1,000 feet amsl onto a heading of 257° M. Take-off was at 0729 hrs UTC (1229 hrs local); the weather was good with no cloud, but visibility limited to 3,600 metres in smoke.

As the commander made the right turn after takeoff the ADI 'Comparator' warning triggered; his recollection was that the buzzer sounded, the 'ATT' flag appeared on his ADI, the Instrument 'Warn' flashing red and 'ATT' steady amber lights illuminated. When the warning activated, the commander looked at both the standby horizon and the first officer's ADI and realised that his own ADI indication was in error. He instructed the first officer to take control. Once he had done so, the commander selected his ATTITUDE/COMP STAB switch to ALT. After approximately 5 seconds, his ADI indicated correctly and the warnings disappeared.

This instrument configuration was retained until the aircraft was level and steady in the cruise at an altitude of 9,600 metres. The commander then reselected NORM on the ATTITUDE/COMP STAB switch. In that configuration, the captain's ADI appeared to indicate correctly with wings level but, for turns in either direction the instrument continued to indicate wings level. From take-off and throughout the flight with NORM or ALT selected, the pitch indication appeared to be reliable. The commander returned the ATTITUDE/COMP STAB switch to ALT and left it there for the rest of the flight. There were no other problems with the aircraft.

On arrival on 'Stand Alpha 6' at Stansted, the crew made an entry into the Technical Log including the phrase: 'Captain's ADI unreliable in roll'; the flight engineer had used the 'Fault Reporting Manual' and 'Fault

Codes' for the correct terminology. The commander returned his ATTITUDE/COMP STAB switch to the NORM position before leaving the aircraft. An operator's ground engineer met the aircraft and the flight engineer explained to him the effect of selecting ALT on the captain's ATTITUDE/COMP STAB switch. The inbound flight crew did not meet with any of the outbound crew.

### **Inertial Navigation System and Attitude Director Indicators**

The aircraft was equipped with three independent Inertial Navigation Systems (INS). Each INS computed navigation data and sensed the aircraft displacement in pitch, roll and azimuth from local horizontal and vertical references. Output signals from the INS were used for a variety of navigation functions and to provide input to the captain's and first officer's ADIs. Each INS had an Inertial Navigation Unit (INU) located in the main equipment centre, a Control Display Unit (CDU) on the centre console and a Mode Selector Unit on the Overhead Panel.

A set of Navigation Transfer Switches was located at the bottom of each of the captain's and first officer's Instrument panels, both included a two position ATTITUDE/COMP STAB switch. With both switches selected to the guarded NORM position, the captain's ADI received its attitude information from INU No 1 and the first officer's ADI received its attitude information from INU No 2. Either pilot can switch his ADI data source to INU No 3 by selecting from NORM to ALT on the ATTITUDE/COMP STAB switch.

A comparator module monitored the pitch and roll indications on the two ADIs; a warning would be triggered if a difference of 4 degrees was detected in either axis for more than one second. The warning consisted of flashing red instrument 'warn' lights and amber 'ATT' lights on the instrument panels in front of each pilot. The subject aircraft was additionally equipped with a warning buzzer, incorporated in production. If the 'Warn' light was to be pushed, the 'Buzzer' would cancel, the 'Warn' light extinguish and the 'ATT' light dims. The 'ATT' lights would remain until the bank and/or pitch difference returned to less than 4°.

In the event of an ADI disagree, the pilots could refer to a standby attitude indicator, which was an independently powered, self-contained gyro instrument, located on the left side of the Centre Instrument Panel.

### **Pre-flight maintenance**

The aircraft had arrived on Stand at 1505 hrs. During the subsequent turnround, the operator's ground engineer was involved in rectification of the reported instrument fault. However, he was fatally injured on the accident flight; additionally, no copy of the Technical Log for the flight from Tashkent to Stansted was left at Stansted. The result was that there was no record of what the ground engineer entered in the Technical Log to clear the fault and no way of knowing if he briefed the on-coming commander about the fault.

A maintenance company at Stansted had a contract with the operator to provide engineering support for turnround and rectification of their aircraft. When HL-7451 arrived on Stand, a licensed engineer was tasked with attending the aircraft. After checking the oil levels, which were satisfactory, he completed a 'Walk around' before going up to the flight deck where he met an operator's engineer, whom he had previously noticed also doing a 'Walk around'. The two engineers confirmed the oil checks and then left the flight deck to complete the operator's Boeing 747 transit checklist; each item on the checklist was designated T1, T2 or T3 and required a signature. The local engineer stated that the operator's engineer asked him to cover the T2 and T3 checks and that he, the operator's engineer would complete the two T1 checks. The T1 checks were to: 'Accomplish final walk around inspection' and 'check the maintenance and flight log and rectify all flight squawk items'.

Then, as the local engineer was about to leave to complete his checks, the operator's engineer took him back to the flight deck because the incoming crew had reported an aircraft defect. The operator's engineer gestured towards an entry in the Technical Log and then towards the Captain's ADI and reportedly said that he wanted the appropriate tools to remove the ADI and cleaning fluid to clean the connectors. The local engineer looked at the entry and saw that it related to a defect with the captain's ADI but could not recall the precise wording. He did recollect the words 'unreliable indication', 'normal' and 'alternate' but was unsure if these were written in the Technical log or mentioned in conversation. However, as avionics was not his

discipline he was not able to judge the nature of the fault. Nevertheless, as the task of removing the ADI was straight forward, he went to his van for tools before returning and removing the ADI. During the latter part of this task, the operator's engineer sat in the first officer's seat and watched the procedure. Then, with the ADI removed the operator's engineer noticed that Socket No 2 on the smaller plug had been pushed back and he seemed to indicate that he felt this was significant. At that point, the local engineer stated that he would contact an avionics engineer with the necessary tools and expertise to reseat the socket. He contacted a colleague who could attend in about half an hour.

On his arrival, the avionics engineer went to the flight deck and met the operator's engineer. His recollection was that the operator's engineer pointed to the hole in the instrument panel where the captain's ADI should be and said that: 'there is a push back pin and can you reset it?' The avionics engineer was confident that he fully understood the request. He examined the connectors and identified a pushed back socket, 'Socket No 2 of the Small Connector'. After going to his vehicle for a special tool, he returned and heard the distinctive 'click' as the socket was relocated in position. He confirmed the remedial action by connecting the ADI and then disconnecting it and checking both of the plugs and sockets; he then reconnected the ADI and located it in the instrument panel. Prior to testing the instrument, he turned on all three INS. About this time, another operator's employee wearing flight crew uniform came to the flight deck and sat in the first officer's seat. There was some problem with inserting the 'present position' into the INS and this individual successfully carried out that action. Thereafter, the avionics engineer was aware of the 'ATT' flag on each ADI retracting from view but not simultaneously and therefore causing the 'Comparator' warning to activate; he heard an audio warning and saw a visual warning. He then pressed the 'Test' button on the captain's ADI and saw the correct instrument response, which also activated the 'Comparator' warning. The test was repeated with the same results with the ATTITUDE/COMP STAB switch in ALT. He then secured the ADI to the instrument panel before successfully testing it a further time in NORM. Following a check that the captain's instrument lights were serviceable, the avionics engineer asked the operator's engineer, who had been watching throughout the procedure, if he could be of any further assistance. He replied that he did not require any further help. At an early stage in the rectification, the avionics engineer had asked what the problem was and was shown the Technical Log entry; he recalled the entry as: 'The captain's ADI unreliable in roll'. He also stated that the operator's engineer said that he would complete the Technical Log.

### **Future activity**

The Chief Inspector of Air Accidents has ordered an Inspector's Investigation into the circumstances of the accident under provision of the Civil Aviation (Investigation of Air Accidents and Incidents) Regulations 1996.

Work at the accident site continues to recover and identify, flight instruments, avionics boxes and other electrical equipment. Work has already begun, in co-operation with all relevant organisations, to reinstate the landscape to its original condition.

Further areas of focus for the ongoing investigation will include efforts to refine the CVR and FDR data; more detailed consideration of the INS and ADI systems failure modes and warnings; detailed review of the maintenance activity at Stansted; review of the operator's engineering and flight crew training practices and standard operating procedures.

# Boeing 747-2B5F, HL-7451: Main document

## Contents

<b>Air Accidents Investigation Branch.....</b>	<b>4</b>
<b>Aircraft Accident Report No:3/2003 (EW/C99/12/04).....</b>	<b>4</b>
<b>Synopsis.....</b>	<b>5</b>
<b>1 Factual Information.....</b>	<b>7</b>
<b>1.1 History of the flight.....</b>	<b>7</b>
<b>1.2 Injuries to persons.....</b>	<b>12</b>
<b>1.3 Damage to aircraft.....</b>	<b>12</b>
<b>1.4 Other damage.....</b>	<b>12</b>
<b>1.5 Personnel information.....</b>	<b>12</b>
<b>1.6 Aircraft information.....</b>	<b>14</b>
<b>1.7 Meteorological information.....</b>	<b>23</b>
<b>1.8 Aids to navigation.....</b>	<b>24</b>
<b>1.9 Communications.....</b>	<b>25</b>
<b>1.10 Aerodrome information.....</b>	<b>27</b>
<b>1.11 Flight recorders.....</b>	<b>27</b>
<b>1.12 Wreckage and impact information.....</b>	<b>31</b>
<b>1.13 Medical and pathological information.....</b>	<b>35</b>
<b>1.14 Fire.....</b>	<b>35</b>
<b>1.15 Survival aspects.....</b>	<b>35</b>
<b>1.16 Tests and research.....</b>	<b>36</b>
<b>1.17 Organisational and Management Information.....</b>	<b>38</b>
<b>1.18 Additional information.....</b>	<b>48</b>
<b>2 Analysis.....</b>	<b>50</b>
<b>2.1 Introduction.....</b>	<b>50</b>
<b>2.2 The flight instrument system.....</b>	<b>51</b>
<b>2.3 Fault reporting.....</b>	<b>53</b>
<b>2.4 Fault diagnosis.....</b>	<b>53</b>
<b>2.5 Rectification action and recording.....</b>	<b>54</b>
<b>2.6 Engineer licensing issues.....</b>	<b>56</b>



<b>2.7 Crew anticipation of a recurrence of the fault .....</b>	<b>57</b>
<b>2.8 Pre-departure crew distractions .....</b>	<b>58</b>
<b>2.9 Crew actions after takeoff from Stansted .....</b>	<b>59</b>
<b>2.10 Dangerous Air Cargo (DAC).....</b>	<b>63</b>
<b>2.11 Hazardous materials .....</b>	<b>64</b>
<b>3 Conclusions .....</b>	<b>64</b>
<b>4 Safety Recommendations.....</b>	<b>67</b>
<b>Appendix A - B747 Transit Checklist.....</b>	<b>68</b>
<b>Appendix B - Figures 1 and 2 - Flight Director Indicator Display .....</b>	<b>69</b>
<b>Appendix C - Functional diagram of FDI.....</b>	<b>70</b>
<b>Appendix D - Figure 1 - Central Instrument Warning System Schematic.....</b>	<b>71</b>
<b>Appendix D - Figure 2 - Section of Indicator Circuit Diagram .....</b>	<b>72</b>
<b>Appendix E - Figure 1 - Drawing of INU .....</b>	<b>73</b>
<b>Appendix E - Figure 2 - Attitude interface and Attitude Repeater circuit boards</b>	<b>74</b>
<b>Appendix E - Figure 3 - Schematic of INU attitude signal flow.....</b>	<b>75</b>
<b>Appendix F - Figure 1 - UK AIP entry for Dover 6R SID.....</b>	<b>76</b>
<b>Appendix F - Figure 2 - Jeppesen plate 30-3D for Dover 6R SID .....</b>	<b>77</b>
<b>Appendix F - Figure 3 - UK AIP entry for Stansted ILS/DME Runway 23.....</b>	<b>78</b>
<b>Appendix F - Figure 4 UK AIP entry for Stansted Aerodrome Chart.....</b>	<b>79</b>
<b>Appendix G - Figures 1 - 2 and 3 - FDR Unit.....</b>	<b>80</b>
<b>Appendix G - Figure 4 - CVR unit as found in wreckage .....</b>	<b>81</b>
<b>Appendix H - Page 1 - CVR transcript extracts.....</b>	<b>82</b>
<b>Appendix H - Page 2 - CVR transcript extracts.....</b>	<b>83</b>
<b>Appendix H - Page 3 - CVR transcript extracts.....</b>	<b>84</b>
<b>Appendix I - M-cab - Summary of runs - page 1.....</b>	<b>85</b>
<b>Appendix I - M-cab - Summary of runs - page 2.....</b>	<b>86</b>
<b>Appendix I - Figure 1 - M-cab Full backdrive profile .....</b>	<b>87</b>
<b>Appendix I - Figure 2 - M-cab Pilot interaction profile.....</b>	<b>88</b>
<b>Appendix I - Figure 3 - M-cab Pilot interaction profile.....</b>	<b>89</b>
<b>Appendix I - Figure 4 - M-cab pilot interaction profile.....</b>	<b>90</b>
<b>Appendix I - Figure 5 - M-cab Pilot interaction profile.....</b>	<b>91</b>
<b>Appendix I - Figure 6 - M-cab Pilot interaction profile.....</b>	<b>92</b>

<b>Appendix J - FDR plot .....</b>	<b>93</b>
<b>Appendix K - OS map and radar track data .....</b>	<b>94</b>
<b>Appendix L - Figure 1 - Impact parameters.....</b>	<b>95</b>
<b>Appendix L - Figure 2 - Wreckage distribution .....</b>	<b>96</b>
<b>Appendix M - Figure 1 and 2 - Front view of ADI as found .....</b>	<b>97</b>
<b>Appendix M - Figures 3 to 6 - Assessment of GYRO Flag Positions.....</b>	<b>98</b>
<b>Appendix N - Figure 1 - Standard Ground Handling Agreement Section 9 .....</b>	<b>99</b>
<b>Appendix N - Figure 2 - Standard Ground handling Agreement Para 6.....</b>	<b>100</b>
<b>Appendix O - Figure 1 - Diagram of Captain's FDI presentations .....</b>	<b>101</b>
<b>Appendix P - Diagram of estimated Captain and First Officer's FDI presentations</b>	<b>102</b>
<b>Appendix Q - Attitude reference at moment of impact .....</b>	<b>103</b>

## Air Accidents Investigation Branch

### Aircraft Accident Report No:3/2003 (EW/C99/12/04)

<b>Registered Owner and Operator</b>	<b>Korean Air</b>
Aircraft Type	Boeing 747-2B5F
Nationality	Korean
Registration	HL-7451
Place of Accident	Near Great Hallingbury and Hatfield Forest, Near London Stansted Airport, Essex
Latitude:	51° 51.385'N
Longitude:	000°12.988'E
Date and Time	22 December 1999 at 1838 hrs (all times in this report are UTC)

## Synopsis

The accident was notified to the Air Accidents Investigation Branch (AAIB), by the London Air Traffic Control Centre, at 1842 hrs on 22 December 1999. The following Inspectors participated in the investigation:

Dr D F King	Investigator in Charge	Mr D S Miller	Operations
Mr P T Claiden	Engineering	Mr R W Shimmons	Operations
Mr R D G Carter	Engineering	Mr A H Robinson	Engineering
Mr S W Moss	Engineering	Ms A Evans	Flight Recorders

The investigation was supported by Accredited Representatives and Technical Advisers from South Korea and the USA.

The aircraft arrived at Stansted Airport after a flight from Tashkent, Uzbekistan. Prior to leaving the aircraft, the flight engineer made an entry in the Technical Log to the effect that the captain's Attitude Director Indicator (ADI) was 'unreliable in roll'; he also verbally passed the details to the operator's ground engineer who met the aircraft on arrival. This fault had been detected after takeoff from Tashkent. The inbound flight crew then left the aircraft without meeting the outbound crew who were due to operate HL-7451 to Milan (Malpensa) Airport later that day.

During the turnaround, some cargo was offloaded and other cargo, which had been transported by road from London, was loaded. At the same time, the operator's ground engineer and two other engineers from a local maintenance organisation carried out rectification action in an attempt to correct the reported fault with the ADI. The loading was almost complete when the outbound crew arrived; this crew comprised the commander who was to be the handling pilot, the first officer and the flight engineer. Prior to engine start, the commander accompanied the load controller through the aircraft to check the security of the cargo, and then checked the load sheet before signing it and leaving a copy with the load controller. The operator's ground engineer who had met the aircraft on its arrival at Stansted also boarded the aircraft for the flight to Milan.

At 1727 hrs, the aircraft was ready to depart. However, there were delays caused by various factors outside of the crew's control and they were not cleared to taxi until 1825 hrs. By 1835 hrs, the crew had contacted the 'Tower' and were instructed: "AFTER THE NEXT LANDING AIRCRAFT ON FINAL LINE UP AND WAIT RUNWAY 23". Subsequently, at 1836 hrs HL-7451, using the callsign KAL 8509 was cleared to take off with a reported surface wind of 190°/18 kt. The Tower controller considered that the takeoff was normal and the aircraft disappeared from sight as it entered the cloud base at about 400 feet agl. At 1838 hrs, as the aircraft indicated altitude passed 1,400 feet, KAL 8509 was transferred to 'London Control' on frequency 118.82 MHz. The crew had been cleared for a departure procedure, which required a left turn at 1.5 nm from the Stansted DME (co-incident with the 152° radial from Barkway VOR) onto a radial of 158° to the Detling VOR. No radio calls were heard from the aircraft subsequent to the frequency transfer instruction from 'Stansted Tower'. The ATC personnel in the 'Tower' then saw an explosion to the south of the airport and immediately implemented their emergency procedures. The Aerodrome Fire Service recorded receipt of the alerting action from ATC at 1840 hrs. Essex police recorded the first emergency call from a member of the public at 1843 hrs.

Investigations revealed that, throughout the accident flight, the captain's ADI indicated the correct pitch attitude but that the roll attitude remained at a wings level indication. Radar and Flight Data Recorder data showed that the aircraft commenced a turn to the left but that this turn was continuous until impact with the ground. At impact, the aircraft was assessed to be pitched approximately 40° nose down, banked close to 90° to the left and with a speed in the region of 250 to 300 kt.

The investigation identified the following causal factors:

1	The pilots did not respond appropriately to the comparator warnings during the climb after takeoff from Stansted despite prompts from the flight engineer.
2	The commander, as the handling pilot, maintained a left roll control input, rolling the aircraft to approximately 90° of left bank and there was no control input to correct the pitch attitude throughout the turn.
3	The first officer either did not monitor the aircraft attitude during the climbing turn or, having done so, did not alert the commander to the extreme unsafe attitude that developed.
4	The maintenance activity at Stansted was misdirected, despite the fault having been correctly reported using the Fault Reporting Manual. Consequently the aircraft was presented for service with the same fault experienced on the previous sector; the No 1 INU roll signal driving the captain's ADI was erroneous.
5	The agreement for local engineering support of the Operator's engineering personnel, was unclear on the division of responsibility, resulting in erroneous defect identification, and mis-directed maintenance action.

Six safety recommendations were made.

## **1 Factual Information**

### **1.1 History of the flight**

#### **1.1.1 Planned schedule**

The aircraft was on a scheduled freight service from Kimpo Airport, Seoul, South Korea via Tashkent to London Stansted Airport before returning to Seoul via Milan (Malpensa) Airport and Tashkent. The stops in Tashkent were planned to cater for a crew change and refuelling only. The stopover at Stansted allowed for on/off loading of freight and a further crew change.

#### **1.1.2 The accident flight**

The aircraft arrived at Stansted Airport at 1505 hrs on 22 December 1999, after the flight from Tashkent, Uzbekistan. Prior to leaving the aircraft, the flight engineer made an entry in the Technical Log to the effect that the captain's Attitude Director Indicator (ADI) was 'unreliable in roll'; he also verbally passed the details to the operator's ground engineer who met the aircraft on arrival. The inbound flight crew then left the aircraft without meeting the outbound crew who were due to operate HL-7451 to Milan (Malpensa) Airport later that day.

During the turnaround, some cargo was offloaded and other cargo, which had been transported by road from London Heathrow, was loaded. The total cargo on board for the sector to Milan was 140,452 lb. The loading was almost complete when the outbound crew arrived; this crew comprised the commander who was to be the handling pilot, the first officer and the flight engineer. The dispatcher went to the cockpit to meet the outbound crew and gave them the navigation logs and weather information for their flight. Prior to engine start, the commander accompanied the load controller through the aircraft to check the security of the cargo, and then checked the load sheet before signing it and leaving a copy with the load controller. The load sheet copy indicated that the aircraft weight for takeoff was 548,352 lb; this included 68,300 lb of fuel. The operator's ground engineer who had met the aircraft on arrival at Stansted boarded the aircraft for the flight to Milan.

At 1727 hrs, the crew called 'Stansted Delivery' on frequency 125.55 MHz for their flight clearance; however, this frequency is only manned when a high number of airport movements are planned. At 1729 hrs after two unsuccessful attempts to contact ATC on the 'Delivery' frequency, the crew contacted 'Stansted Ground' on frequency 121.72 MHz to request start and push back clearance from their position at Stand Alpha 6. They were informed that ATC had no details for their flight and so were requested to standby. Then, at 1733 hrs, the crew were informed that no flight plan had been received and that they should contact their handling agents. The agents submitted the flight plan and at 1742 hrs the crew of HL-7451, call sign KAL 8509, were advised that their clearance was to Malpensa (Milan) on a Dover 6R Standard Instrument Departure (SID) with a transponder setting of 2230; the crew read back their clearance correctly.

There was then some delay providing a tug for the aircraft and, at 1813 hrs, the crew requested push back clearance. During the push back however, the tug experienced problems and was unable to complete the manoeuvre. The result was that HL-7451 was left in a position from which it required marshalling onto the taxiway centre-line. By 1823 hrs the marshalling vehicle was in position and, at 1825 hrs, KAL 8509 was cleared to taxi to 'Hotel November' (holding point for Runway 23) via 'Hotel Lima'. Shortly after, the 'Ground' controller transferred KAL 8509 to 'Tower' on frequency 123.8 MHz.

During the taxi to the holding point the crew contacted the 'Tower' and subsequently the commander voiced concern that his DME (Distance Measuring Equipment) indication was unreasonable, displaying 399 nm. The first officer confirmed that his DME indication was the same. The commander asked, presumably the first officer, how they were to identify the 1.5 nm point for the SID turn, at which moment the flight engineer said, "NOW ITS WORKING CORRECTLY". At 1835 hrs they

were instructed, "AFTER THE NEXT LANDING AIRCRAFT ON FINAL LINE UP AND WAIT RUNWAY TWO THREE". Subsequently, at 1836 hrs, KAL 8509 was cleared to take off with a reported surface wind of 190°/18 kt. After rotation the first officer confirmed a positive rate of climb and the commander called for "GEAR UP". Shortly after the first officer called "PASSING NINE HUNDRED FEET", the commander confirmed with him that they should turn at 1.5 DME and then said that his DME was not working. There was then a short exchange between the two pilots, confirming the departure heading after the 1.5 DME turn as 158°, following which the flight engineer called "BANK, BANK".

The Tower controller considered that the takeoff was normal and, at 1836 hrs, as the aircraft indicated altitude passed 1,400 feet, transferred KAL 8509 to 'London Control' on frequency 118.82 MHz. Shortly after the first officer had acknowledged the change of frequency, the commander asked him to obtain radar vectors. The flight engineer then made a further, more urgent, call of "BANK". The air assistant, seated alongside the tower controller, who also watched the takeoff and described it as normal, watched the aircraft climbing into cloud. No radio calls were heard from the aircraft subsequent to the frequency transfer instruction from 'Stansted Tower'. ATC personnel in the Tower then saw an explosion to the south of the airport and realised that KAL 8509 had crashed and immediately implemented their emergency procedures. The Airport Fire Service (AFS) recorded receipt of the alerting action from ATC at 1840 hrs and dispatched all available vehicles and crews to the reported accident position.

Other witnesses heard and saw the aircraft impact the ground. Some reported feeling the shock waves and others reported seeing the aircraft flying much lower than normal. One eyewitness, close to the impact location, reported two fireballs either just before or just after the aircraft crashed. The second fireball was intense and reported as 'Mushroom' shaped. Essex police recorded the first emergency call at 1843 hrs and initiated their emergency response.

### **1.1.3 Previous sector (Tashkent to Stansted)**

The aircraft had flown from Seoul to Stansted with a stop at Tashkent for refuelling and a crew change. The new crew arrived at the aircraft in Tashkent, met the crew that had operated from Seoul and were told that the aircraft was serviceable.

On 22 December 1999 at 0729 hrs (1229 hrs local time), following the 'turnaround', the aircraft departed Tashkent from Runway 08 Left. The weather was fine with a visibility of 3,600 metres in smoke, sky clear, temperature 14°C, dewpoint -2°C and a QNH of 1024 mb. The departure required a climb straight ahead to 1,000 feet before turning right onto a heading of 257°.

The commander was the handling pilot and at 1,000 feet, after a full power takeoff, the commander commenced the right turn. He reported that his ADI operated normally until the aircraft reached an angle of bank of between 10° and 15°. As the angle of bank increased further the attitude comparator warning activated (both aural and visual warnings). The commander reported that he compared his ADI indication with the standby horizon and the first officer's ADI, and with peripheral outside visual cues realised that, although his ADI was showing the correct pitch attitude, it was not showing the correct angle of bank. He handed over control of the aircraft to the first officer who continued to fly the departure and the crew cancelled the aural warnings; the commander reported that the 'Attitude' warning flag on his ADI appeared, remained visible and the amber 'ATT' light dimmed. The commander then selected 'ALT' on the 'Attitude and Compass stabilization selector switch' (ATT/COMP/STAB switch - captain's attitude data source transfer switch) and within an estimated five seconds his ADI displayed the correct roll indication and all the warnings disappeared.

Five minutes later, with the aircraft now established in the climb, the commander resumed handling duties. When level and with the autopilot engaged, the commander reselected 'NORM' on his 'Attitude and Compass stabilization selector switch'. The captain's ADI appeared to operate normally until the aircraft banked during track changes en route. Both during turns to the right and left the captain's ADI remained 'frozen' in roll activating the comparator warning each time there was a discrepancy of more than 4° in roll for more than one second. The commander elected to continue the

flight with the selector set to 'ALT'. There were no other problems with the aircraft during its flight to Stansted.

The problem with the captain's ADI was entered in the Technical Log by the flight engineer. The Technical Log, which was subsequently carried on the aircraft, was destroyed in the accident. However, the flight engineer remembered entering the words 'captain's ADI unreliable in roll' and consulted the 'Fault Reporting Manual' (FRM) for the correct terminology and fault code. He also spoke with the company ground engineer, who met the aircraft on its arrival at Stansted, and explained the effects of selecting 'ALT'. The commander reported that he returned the changeover switch to 'NORM' before he left the flight deck. The inbound crew left the aircraft before the outbound crew arrived. It is not known whether any verbal message concerning the fault was passed via the ground engineer to the new crew.

### **1.1.3.1 Fault Reporting Manual (FRM) and Fault Isolation Manual (FIM)**

The FRM is supplied by the manufacturer and is specific to the particular model of aircraft for which it is supplied. It was carried on the aircraft and the flight engineer from the inbound flight recalled that he used the manual and entered the appropriate fault code. Since no copy of the Technical log was left at Stansted, this cannot be verified but a review of previous entries in the aircraft log book showed that Korean Air (KAL) crews routinely used the FRM and the words 'not reliable' are those used in the manual to describe the fault.

The full FRM wording was:

CAPT'S ADI (ATT DISPLAY NOT RELIABLE, HAS GYRO FLAG IN VIEW). DISPLAY OK WHEN ALTERNATE ATT SELECTED.

The FRM code appropriate to this description was '34 41 AD 01'. The first numerical part of the code is the ATA reference for Attitude and Inertial Navigation equipment, the 'AD' describes the fact that the ADI display was 'OK' when the Comp/stab. switch was selected to alternate and the '01' refers to the captain's instrument.

The FIM would normally be held by ground engineers but KAL had not supplied their Stansted engineering support contractor with a copy of the manual and it is not believed that the KAL handling engineer had one amongst the documents he brought with him. It contains essentially the same information as the FRM but with the addition of tables to interpret the code into a maintenance action. In the case of 34 41 AD, this decodes into:

REPLACE INU B109, B110 OR B173 (E2). MM 34-41-03.

The 01 suffix tells the engineers that it is No 1 Inertial Navigation Unit (INU) that is affected. Had the FIM been used, therefore, the correct course of action would have been identified.

### **1.1.4 Pre-flight maintenance**

The aircraft arrived on Stand at Stansted at 1505 hrs where it was met by local Engineer 'A' (see paragraph 1.17.8.2). He set about checking the engine oil levels, which were satisfactory, and completed an external 'walk around' check. At the same time he had noticed a man wearing a 'high-visibility' coat, who he assumed to be the KAL representative doing a similar check. When Engineer 'A' climbed up to the flight deck, he met the latter person there, confirmed his identity and received instructions that a 'Transit' check was required of him. The two engineers cross-checked the oil quantities on the cockpit gauges and then left the flight deck to complete the operator's Boeing 747 Transit Checklist (see Appendix A). Each item on the checklist was designated T1, T2 or T3 and required a signature. Engineer 'A' stated that the KAL engineer asked him to cover the T2 and T3 items and that he, the KAL engineer, would complete the two T1 checks. The T1 checks were to:

'Accomplish final walk around inspection' and 'check the maintenance and flight log and rectify all flight squawk items'.



Then, as Engineer 'A' was about to leave to complete his checks, the KAL engineer took him back to the flight deck because the incoming crew had reported an aircraft defect. The operator's engineer gestured towards an entry in the Technical Log and then towards the captain's ADI and reportedly said that he wanted the appropriate tools to remove the ADI and cleaning fluid to clean the connectors. Engineer 'A' looked at the entry and saw that it related to a defect with the captain's ADI but later could not recall the precise wording. He did, however, recollect the words 'unreliable indication', 'normal' and 'alternate' but was unsure if these were written in the Technical Log or mentioned in conversation. However, as avionics was not his discipline he was not able to judge the nature of the fault. Nevertheless, as the requested task of removing the ADI was straight forward, he went to his van for tools before returning and removing the ADI. During the latter part of this task, the KAL engineer sat in the first officer's seat and watched the procedure which involved unscrewing the instrument from the panel and disconnecting two electrical connectors on the back of the unit. Then, with the ADI removed the KAL engineer noticed that Socket No 2 on the smaller plug (ie the half of one connector forming part of the aircraft wiring) had been pushed back and he seemed to indicate that he felt this was significant. At that point, Engineer 'A' stated that he would contact an avionics engineer with the necessary tools and expertise to reseat the socket. Using his radio, he contacted a colleague (Engineer 'B') who could attend in about half an hour.

On his arrival at the aircraft, Engineer 'B' went to the flight deck and met the KAL engineer. His recollection was that the operator's engineer pointed to the hole in the instrument panel where the captain's ADI should be and said that: "there is a push back pin" and "can you reset it?" Engineer 'B' was confident that he fully understood the request. At an early stage in the rectification, the avionics engineer had asked what the problem was and was shown the Technical Log entry; he later recalled the entry as: 'The captain's ADI unreliable in roll'. He examined the connectors and identified a pushed back socket; 'Socket No 2 of the Small Connector'. After going to his vehicle for the special tool, he returned and performed the task, hearing the distinctive 'click' as the socket was relocated in position. He confirmed the remedial action by connecting the ADI and then disconnecting it and checking both of the plugs and sockets. He then reconnected the ADI and located it in the instrument panel.

Prior to testing the instrument, he turned on all three Inertial Navigation Systems (INS). About this time, another operator's employee wearing flight crew uniform came to the flight deck and sat in the first officer's seat. There was some problem with inserting the 'present position' into the INS and this individual successfully carried out that action. Thereafter, Engineer 'B' was aware of the 'ATT' flag on each ADI retracting from view but not simultaneously. This caused the 'Comparator' warning to activate with its associated audio and visual warning. He then pressed the 'Test' button on the captain's ADI and saw the correct instrument response, which also activated the 'Comparator' warning. The test was repeated with the same results with the Attitude and Compass Stabilization switch selected to 'ALT'. He then secured the ADI to the instrument panel before successfully testing it a further time in 'NORM'. Following a check that the captain's instrument lights were serviceable, Engineer 'B' asked the KAL engineer, who had been watching throughout the procedure, if he could be of any further assistance. He replied that he did not require any further help.

In addition to declining Engineer 'B's offer of further assistance, both local engineers, who had been present during the work described above, recalled that the KAL engineer had stated that he would "take care of the paperwork". As Engineer 'B' left the aircraft, Engineer 'A' completed his signatures against the T2 and T3 items on the Transit Checklist before leaving the flight deck to perform his duties as 'departing engineer'. These involved a final external check and monitoring the engine starts and pushback operations.

No copies of either the Transit Checklist or the relevant Technical Log page were retained at Stansted.

The United Kingdom Air Navigation Order 2000 states:-

(a) Subject to sub-paragraph (b) the technical log referred to in this article shall be carried in the aircraft..... **and copies of the entries referred to in this article shall be kept on the ground. (bold added)**

(b) In the case of an aeroplane of which the maximum total weight authorised does not exceed 2730 kg, or a helicopter, .....

The above is also reflected in ICAO standard Annex 6, 3.1.1 which has a requirement for an operator to comply with the regulations of the State in which operations are conducted; namely the UK ANO 2000.

This same non-compliance with ICAO standards was noted during a CAA Ramp Inspection of a KAL passenger service at London Heathrow airport on 26 April 1999. As a result, a letter was sent by the UK Department of Environment Transport and the Regions (DETR) to the Director General of the KCAB dated 11 May 1999, pointing out this, and other, discrepancies. On 16 November, a letter was received by DETR from KAL VP Corporate Safety saying that they had added extra sheets in the Technical Log so that one could be left behind. It is understood that British Airways, who were handling KAL aircraft at Heathrow (see paragraph 1.17.7), had already been routinely taking a photocopy of the relevant Technical Log pages.

## 1.2 Injuries to persons

The four persons on board the aircraft, the three flight crew members and the company ground engineer, were fatally injured during the impact. No persons on the ground were physically injured.

## 1.3 Damage to aircraft

The aircraft was destroyed.

## 1.4 Other damage

Immediately prior to striking the ground, the aircraft severed a set of low voltage power wires supplying power to an adjacent farm. The farm was without electrical power for some days. The main impact crater was formed in the retaining earthworks of a man-made lake and, although no water was lost from the lake at this time, significant reconstitution of the area around the crater was later required to ensure the structural integrity of the earthworks. Burning fuel from the aircraft affected an area up to a distance of approximately 500 metres from the crater. Wreckage was deposited into the lake, across several fields and into the western side of Hatfield Forest, an area designated by English Nature as both a Site of Special Scientific Interest (SSSI) and a National Nature Reserve (NNR). Further damage was necessarily caused to the site during wreckage recovery. The lake was later drained during this process and areas of fuel contaminated soil were required to be removed for disposal. After the site had been cleared, restoration of the landscape was necessary, a process which was not expected to be fully complete until several years after the accident.

## 1.5 Personnel information

The flight crew had arrived at London Heathrow Airport at 1615 hrs on 20 December 1999 and then travelled to a hotel at Stansted that evening. At 1630 hrs, on the day of the accident, they were collected from the hotel by car and taken to the aircraft.

### 1.5.1 Commander

Age 57 years	Total flying	13,490 hours
	Total on type:	8,495 hours
	Last 90 days:	208 hours
	Last 28 days:	56 hours
	Last 24 hours:	Nil

Final line check B747 captain conversion: 10 April 1994

Previous types: MD82, Airforce colonel F5As and A37s

Last medical: 4 November 1999 - declared fit

### 1.5.2 First Officer

Age 33 years	Total flying:	1,406 hours
	Total on type:	195 hours
	Last 90 days:	106 hours

	Last 28 days:	48 hours
	Last 24 hours:	Nil

Final line check after B747 conversion: 9 October 1999

Previous types: F100

Last medical: 16 April 1999 - declared fit

### 1.5.3 Flight Engineer

Age 38 years	Total flying:	8,301 hours
	Total on type:	4,511 hours
	Last 90 days:	215 hours
	Last 28 days:	54 hours

Last 24 hours: Nil

Final line check after B747 conversion: 10 April 1994

Last medical: 15 January 1999 - declared fit

### 1.5.4 Ground Engineer:

Maintenance Engineer licenced in 28 November 1980

Ministry of Transport rated on B747 19 March 1981

Rated on A300 30 June 1984

Rated on 747-400 24 November 1995

## 1.6 Aircraft information

### 1.6.1 General

#### 1.6.1.1 Aircraft General Description

Manufacturer:	Boeing
Type:	Boeing 747-2B5F
Aircraft Serial Number:	22480
Year of manufacture:	1980
Certificate of Registration:	Korean Air
Certificate of Airworthiness:	Expires 20 December 2000
Engines:	4 Pratt & Whitney JT9D-7Q turbofan engines
Total airframe hours/landings:	83,011/15,451

#### 1.6.1.2 Powerplants

The four engines installed in HL-7451 were P&W JT9D-7Q turbofans, manufactured by the Pratt & Whitney subsidiary of United Technologies.

### 1.6.2 Flight Director Indicator 329B-8J, Part No. 772-5005-001

#### 1.6.2.1 Description

The Flight Director Indicators (FDIs) on the aircraft were manufactured by Rockwell Collins and were of the electro-mechanical type. This standard of instrument is no longer fitted to current production aircraft. They are also referred to in the aircraft manufacturers documents as Attitude Director Indicators (ADIs). The ADI is a multipurpose indicator, of which two identical units (captain's and first officer's) were fitted on the flight deck. Both were capable of displaying aircraft pitch and roll attitude, pitch and roll commands, speed commands, approach (radio) height, decision height, localiser and glideslope deviation, and rate of turn and slip. These instruments, however, do not contain any source of attitude reference. This information, under normal circumstances, is provided to the captain's unit from INU No 1 and to the co-pilot's unit from INU No 2. Both pilots may select INU No 3 as an alternate source. This is done by selecting the 'Attitude and Compass Stabilization Selector Switch', on their respective flight instrument panels, from 'NORM' to 'ALT'. Warning flags are provided to alert the crew to various failure conditions or when the data presented should be considered unreliable. The face of a similar indicator, under test conditions displaying a pitch and roll attitude and all the warning flags is shown in Appendix B, Figure 1. A view of the indicator with the outer cover removed is shown in Appendix B, Figure 2.

Indication of pitch attitude is achieved by a roller blind, or attitude tape, moving in a vertical sense behind the fixed aircraft symbol (coloured orange). The face of this blind is coloured light blue above the horizon and black below. It is calibrated with horizontal white lines, which represent pitch angles. The blind is supported between upper and lower rollers, which are mounted in a cast frame. These rollers are driven by the pitch servo system within the unit. The lower roller is spring tensioned such that the visible portion of the blind remains under a light tensile load in order to ensure that it remains flat. The frame is mounted such that the roll servo system is able to rotate it through 360°, thereby displaying roll attitude. Attached to the upper section of the frame is a light blue coloured segment intended to represent sky. This remains visible even at extreme nose down pitch attitudes when the blue section of the roller blind would not be visible.

A third ADI was carried on this aircraft as part of the 'fly away' spares kit and the serial numbers of the three units, listed in Korean Air records for this aircraft, were:

Captain's position 8E461

First officer's position 5C2177

Spare 5D2193

The captain's ADI was recorded as having been installed on 15 July 1999 and the first officer's on 16 December 1997. Since their installation the aircraft had flown for some 2,141 and 8,231 hours respectively.

### **1.6.2.2 Flight Director Indicator Attitude Display Failure**

Warning flags are provided to alert the crew to various failure conditions or when the data presented should be considered unreliable. The GYRO (ATT) WARNING FLAG is '*in view when instrument power fails, when display is not valid, or when attitude signal is not valid*'. (Korean Air B-747 Operations Manual, page 07.30.04, JUL 31/75)

Failure of the FDI (ADI) attitude display may be caused either by the failure of the indicator itself, or by an invalid INU attitude signal.

### **1.6.2.3 Operation**

Six separate closed loop servo systems within the ADI control the pitch and roll attitude displays, the command pitch and roll display and the runway lateral and vertical displays. Internal monitor circuits check for proper servo operation, external monitor (INU validity) and control signals and correct power input to the instrument. If a failure is detected, the crew are alerted by the display of one or more of four warning flags. The pitch and roll attitude information, generated by the selected INU, is processed by two separate rate servo loops within the ADI, both of which employ synchro and resolver devices.

### **1.6.2.4 Synchro/resolver operation**

The term 'synchro' is a generic term for a family of electromechanical devices (including resolvers and transolvers) which are often used in angular measurement and positioning systems. The brushless type, as employed in the ADIs, may be thought of as a variable transformer in which, for example, the rotor excitation is 'transformer' coupled to the rotor winding. A synchro can provide an electrical output at the three stator windings terminals (orientated at 120° to each other), which represents shaft angular position, or a mechanical indication, based on shaft position, in response to applied electrical inputs to the stator windings. A resolver is a form of synchro in which there are two separate stator windings, positioned at 90° to each other. Shaft rotation, with an AC voltage applied to the rotor winding, will cause a change in the stator windings output voltage, with one output related to the sine of the rotor angle, the other the cosine of the angle. A transolver may be considered as a type of resolver, with three stator windings set 120° apart, and two rotor windings set at 90° to each other. Thus, if an angular position is referenced to the stator windings, and the sine winding of the rotor is aligned with that position, a minimum or zero output will be achieved (the null point), whilst the cosine winding will output a maximum value. These outputs may be considered as a '0' and a '1' respectively and will occur at two positions 180° apart.

### **1.6.2.5 Attitude servo operation**

The synchro transmitters in the INUs, which sense the pitch and roll attitude of the gyro platform (and hence the attitude of the aircraft), accept an AC reference excitation on their rotor windings. This induces a three wire AC output at the reference frequency at their stator terminals. The amplitude ratios of these line-to-line voltages have an explicit relationship to the angular position of the rotor

shaft and it is these two separate three wire (X, Y and Z) AC signals which are sent to the ADI. The 329B-8J indicator receives this three wire pitch and roll attitude information from its selected INU at transolvers identified respectively as B2 and B3 in Appendix C. An error signal is generated by the 'sine' winding of the transolver rotor, in both the pitch and roll channels, whenever the aircraft attitude (defined by the INU) and the displayed attitude are not the same, and this signal represents the difference between the two. This error signal is compared to a constant phase drive output signal (which ensures that the signal sent to the attitude tape drive motors is in the correct sense) and converted to a DC error signal. This signal is then amplified and used to drive the attitude tape servo motors. As the attitude tape moves, this movement is mechanically fed back to the rotor shafts of transolvers B2 and B3. This repositions their windings to a null position, which reduces the error signal effectively to zero and thus the attitude tape ceases movement at the desired position. The speed of response of this type of system, compared with normal rates of change of aircraft attitude, is such that the ADI will continuously and smoothly indicate varying aircraft attitude, resulting in error signals always close to zero.

### 1.6.2.6 Attitude monitor circuits

Should the error signal be lost, as a result of a defect or broken wire, for example, then the ADI would not sense any change in the aircraft attitude and the pitch or roll attitude display would cease to move. To alert the crew to this possibility, monitor circuits are installed. The rotor windings of resolvers B2 and B3 are positioned such that when the 'sine' winding is nulled, the 'cosine' winding is maximum. A summation monitor, identified as U7 in Appendix C monitors the outputs from B2 and B3, the INU validity input and the 28V DC from the power supply. Under normal conditions, U7 will sense a '1' from the power supply, the INU validity signal and the cosine windings from B2 and B3. The output from the sine windings would normally be a '0' but these two signals are inverted to a '1' before entering the summation monitor U7. Should U7 detect an invalid signal on any of these six inputs, an output will result, triggering the GYRO flag control circuit. This opens the GYRO flag ground line, which allows the flag to appear, this event also being signalled to the Central Instrument Warning System (CIWS).

### 1.6.2.7 Central Instrument Warning

Within the Central Instrument Warning Computer (CIWC) installed in the aircraft is an attitude comparator module (see Appendix D, Figure 1), configured to detect a difference of more than 4° between the pitch or roll indications of the captain's and first officer's ADIs existing for more than one second. Flight deck indications and controls for the CIWS consist of the INSTRUMENT WARNING LIGHT, the ATTITUDE COMPARISON WARNING LIGHT, the COMPUTER MONITOR WARNING LIGHT and the INSTRUMENT WARNING TEST SWITCH. (See Appendix D, Figure 1.) The three light clusters are respectively located on the instrument panel, immediately above the captain's and the first officer's ADI.

The red Instrument Warning Light 'flashes on both pilot's panels when ATT lights are illuminated,' and 'flashes on each pilot's panel when that pilot has the [GYRO (ATT)] flag come into view.' 'Pressing each flashing WARN light will extinguish that light and reset the system.' Both of the amber Attitude Comparison Warning Lights are illuminated 'when a difference of 4 degrees exists in pitch or roll between the two ADI's,' and will 'cause both instrument WARN lights to flash. A 'buzzer' will sound with each flash of the WARN light if the ATT light is also illuminated. Pressing the instrument WARN light dims the ATT light and silences the buzzer. ADI differences must be corrected to extinguish the ATT lights.'

Each ADI contains a pitch and roll differential resolver, driven directly by the motion of, but electrically separate from, the servo loop used to position the attitude tape. Two three-wire position signals, representing the pitch and roll attitude of the first officer's indicator, are sent from these differential resolvers to their corresponding items in the captain's unit. If the attitude displayed is within 4° of that indicated by the first officer's unit, then the two output signals from each of these resolvers will respectively indicate a minimum (nulled position) value, and a maximum value. Any

other condition will trigger the attitude comparator module within the CIWC and signal, after a one second delay, a flashing red INST WARN light and a steady amber ATT light, mounted immediately above each ADI, and an aural warning from two horns, one mounted each side of the flight deck. The flashing red lights and the aural warnings at the captain's and the first officer's positions may be individually cancelled by pressing their respective INST WARN light, but the amber ATT lights will remain illuminated but dimmed until any discrepancy between the ADIs falls below the 4° threshold. If, before either pilot has cancelled the warnings on his side, the attitude discrepancy falls below 4° then both ATT lights will extinguish and both horns will cease but the INST WARN lights will continue to flash until individually cancelled.

Pin number 2 in the electrical connector J1 (the smaller of two connectors on the ADI) located at the rear of the captain's ADI carries the 'Y' line of the three-wire signal from the pitch differential resolver in the first officer's ADI to the corresponding resolver in the captain's unit, Appendix D, Figure 2. Although neither this connector nor its mating plug were recovered from the accident site, information from the ADI manufacturer indicated that should this line become open circuit, the output from the captain's ADI to the pitch attitude comparator module in the CIWC would be such as to trigger the comparator warnings. Maintenance records indicate that the captain's ADI was fitted to HL-7451 some five months prior to the accident. There was no record of any instrument warnings being reported over this period, with the exception of the roll attitude warnings on both the accident and preceding flights.

#### **1.6.2.8 ADI self test**

Each ADI incorporates a self test function, which verifies correct operation of the attitude servo loops within the ADI. It is activated by a press switch (labelled TEST) located at the lower left corner of the instrument's front face. When depressed, the displayed attitude is modified by the addition of 10° pitch-up and 20° right roll signals and, because the outputs from B2 and B3 are no longer nulled, an apparent fault is detected by the summation monitor (U7). This signals the gyro flag control module to remove the ground from the meter movement and the GYRO flag drops into view. When the test signal is removed, the attitude indication will return to normal, if receiving an input from an INU, or remain at the test position if not. With the ADIs installed in an aircraft, the GYRO flag signal is also transmitted to the Central Instrument Warning System (CIWS), such that when the test is activated from the left or right unit, both the captain's and the first officer's INST WARN and ATT lights illuminate. The two attitude comparator aural warnings are also activated. Release of the TEST switch will allow the ADI to indicate the correct attitude, if receiving valid attitude data from an INU, and if this is within 4° of that indicated by the other unit, then the aural warnings will cease and the ATT lights will extinguish. Each red INST WARN light, however, will continue to flash until depressed.

Operation of either ADI TEST switch does not test or verify correct operation of any of the three INUs installed on the aircraft. Nor does the ADI TEST switch test or verify the presence or absence of any INU attitude output signal beyond the indication returning to the pre-test position if an altitude signal is present.

#### **1.6.3 Standby Attitude Indicator**

The standby attitude indicator is an independent unit, which contains its own gyroscope powered from the aircraft's 28V DC Battery Bus through a three phase 115V, 400 Hz static inverter. It is located towards the top of the panel and immediately to the right of the captain's flight instruments. Its display is smaller than that of the ADI and solely indicates the aircraft's attitude in pitch and roll. The standby attitude indicator displays roll attitudes up to 360° and pitch attitudes up to +/- 100 degrees.

#### **1.6.4 Inertial navigation and attitude reference system**

The aircraft was equipped with three Litton Aero Products LTN-72 Inertial Navigation Units (INUs), providing both inertial navigation and attitude referencing. At the heart of each system is a gyro-



stabilised, four gimbal, all-attitude platform. Three X, Y and Z axes accelerometers on the platform sense aircraft movement and generate the signals required for inertial navigation. Two gyros (XY for pitch and roll, and Z for azimuth) maintain the platform level for all flight conditions. Output functions include present position (ie lat/long), steering commands, angular pitch, roll and heading information. Navigation computations are performed by a digital computer within each unit, with data entry and display being via the Control/Display Unit (CDU), located on the flight deck pedestal. A drawing of an INU is shown at Appendix E, Figure 1.

Platform pitch and roll information is picked off the gyros by means of synchros: these are electromechanical devices comprising a rotor and stator. Shaft angle rotation, with an AC voltage applied to the rotor winding, causes a change in the stator winding voltages. Since there are three stator windings, each displaced at 120° to the others, pitch and roll signals are generated in the form of X, Y and Z voltages. These components are in fact similar to those used in the ADIs described in paragraph 1.6.2.4. The synchros form the interface between the mechanical components, ie the gyros, and the electronics. Everything downstream of the synchros is solid state. For the purposes of this investigation, the two electronic assemblies within the INU of primary interest are the attitude interface and attitude repeater. Photographs of these two circuit boards are shown at Appendix E, Figure 2. The schematic diagram at Appendix E, Figure 3 illustrates the attitude signal flow, and combines the functions of the attitude interface and the attitude repeater.

The attitude interface within each INU provides the necessary circuitry to connect the pitch and roll 3-wire (ie X, Y and Z) synchro signals to the attitude repeater, and connect pitch, roll and heading outputs to the aircraft instruments. The synchro signals are fed via open stator monitor circuits to corresponding pitch and roll 'Scott T' input transformers. These convert the 3-wire signals into 2-wire 'resolver format' consisting of sine and cosine signals for driving unity voltage gain power amplifiers in the attitude repeater. (Note: a resolver is a form of synchro in which the stator windings are positioned at 90° to each other, with the two outputs being related to the sine and cosine of the rotor shaft angle. Such components are used in aircraft instruments, such as ADIs. Although no resolvers are used in the attitude interface, the term 'resolver format' is used wherever the pitch and roll information takes the form of the 2-wire sine and cosine signal.) The pitch and roll sine signals from the input transformers are additionally used to drive corresponding unity voltage gain power amplifiers on the attitude interface. These amplified signals are sent to separate output transformers that produce two outputs each, still in 2-wire format, designated Pitch 4 and 5, and Roll 4 and 5. Each amplifier has its own monitoring circuitry.

The attitude repeater provides the necessary circuitry to amplify the sine and cosine signals from the attitude interface. This is accomplished by three pairs of power amplifiers for Pitch and Roll, Nos 1, 2 and 3, with the amplified signals being fed back to the attitude interface. Here, six inverse 'Scott T' transformers convert the resolver format signals back into 3-wire synchro signals capable of driving aircraft instrumentation such as the ADIs. A seventh inverse 'Scott T' transformer handles the azimuth signal. Monitoring circuits in the attitude repeater detect amplifier failures and loss of input signal.

#### 1.6.4.1 INU roll attitude output functions

Each INU generates 5 pitch and 5 roll output signals in addition to the azimuth (heading) signal. The signal destination can vary from one aircraft installation to another. In HL-7451 the roll outputs for the INUs were as follows:

INU No 1 roll outputs:	
Roll 1	Captain's flight director indicator
Roll 2	Autothrottle and upper yaw damper
Roll 3	Weather radar 1 and Flight Data Acquisition Unit

Roll 4	Autopilot/Flight Director 'A' roll computer
Roll 5	Not used

INU No 2 roll outputs:	
Roll 1	First Officer's flight director indicator
Roll 2	Lower yaw damper
Roll 3	Weather radar System 2
Roll 4	Autopilot/Flight Director 'B' roll computer
Roll 5	Not used

INU No 3 roll outputs:	
Roll 1	Not used
Roll 2	Captains's ATT/COMP/STAB switch
Roll 3	First Officer's ATT/COMP/STAB switch
Roll 4	Autopilot/Flight Director 'C' roll computer
Roll 5	Not used

The captain's and first officer's ATT/COMP/STAB switches are normally selected to NORM. If either is selected to ALT, the Roll 2 or Roll 3 output from INU No 3 is fed to the appropriate ADI.

INU No 1 Roll 3 output is the only source of aircraft roll information for the Flight Data Recorder, via the Flight Data Acquisition Unit (FDAU).

#### 1.6.4.2 Monitoring and warning

As well as the monitoring circuits provided in the attitude interface and attitude repeater, many more monitoring functions are provided within the INU, covering, for example, gyro spin-up and platform operating temperature, power supply, and a range of inertial navigation parameters. These monitors, together with a number of Built In Test Equipment (BITE) systems, are able to detect failures and send 'action/malfunction' codes to the Control/Display Unit (CDU) on the flight deck. The codes are used by maintenance personnel in defect rectification and are stored (along with the last computed navigational position) in non-volatile memory in the gyro bias memory within the INU. None of these codes relate to attitude failures however. A 'hard failure', such as a failure of a power supply or a mechanical problem with a gyro gimbal, would result in the INU shutting down together with a red warning light on the CDU.

The monitors in the attitude interface can detect an open circuit condition in the synchro input. The Pitch and Roll Nos 4 and 5 power amplifier, together with the similar amplifiers on the attitude repeater that generate Pitch and Roll signals Nos 1, 2 and 3, each have monitors which compare the inputs and outputs and detect voltage differences corresponding to more than 0.5° roll angle. These generate a warning signal to the attitude repeater, resulting in a Primary or Auxiliary Pitch/Roll Warning from the INU. An open stator condition or a fault in Pitch/Roll No 1 signal results in a Primary Warning. Auxiliary Warnings are generated in the event of failures in the other Pitch/Roll channels. The Primary Warning effectively removes the 'INU valid' signal sent to the ADI on the

flight deck, and would result in the GYRO flag being biased into view on the face of the instrument. The same signal is sent to the instrument warning computer, resulting in the 'ATT' caption being illuminated. There is no flight deck display specific to INU attitude reference failure, apart from the resultant detection of more than 4° difference through the attitude comparator module of the Central Instrument Warning Computer.

As far as the installation of INU No 1 in the KAL aircraft is concerned, the Primary Warning, like the Pitch/Roll No 1 signals, is routed via the captain's ATT/COMP/STAB switch. The Auxiliary Warning is sent to the Autopilot/Flight Director 'A' pitch and roll computers.

#### 1.6.4.3 INU reliability history

Litton Aero Products provided INU fleet reliability data that indicated fluctuating values from one month to another. However, a typical three month moving average indicated a Mean Time Between Unscheduled Removals (MTBUR) of 662 hours and a Mean Time Between Failures (MTBF) of 1,056 hours. The difference between the two figures represents those units in which defects were not confirmed. The failure categories were not identified in detail, although Litton stated that they were aware of one case of failure indications similar to a 'frozen pitch signal'.

The available reliability data came from those INUs that were returned by airlines to Litton for 'Level 3' rectification, ie defects involving repairs to circuit boards. Many airlines, including KAL, perform Level 3 repairs in their own workshops.

The reliability of KAL's INUs in the years 1997, 1998 and 1999 showed an MTBUR of 899, 877 and 1,032 hours respectively, although the MTBF figures were not quoted. The most common reasons for removal were stated as "Distance errors" and "INS warning light on", which necessitated repairs to the gyros. The third most common reason was "Autopilot inoperative", which was addressed by repairs to the attitude interface and attitude repeater boards.

KAL's experience was broadly in agreement with a UK operator of LTN-72 equipped Boeing 747 aircraft, who quoted an MTBUR of between 700 and 800 hours. During 1994/1995 this particular airline replaced their LTN-72s with LTN-92s, which eliminate the mechanical elements of the INU by the use of ring laser gyros, thus offering improved reliability. This was reflected in the 1999 MTBUR of 3,205 hours.

KAL's records showed that INU No 1 on HL-7451 had the serial number 0976 and had been fitted to the aircraft on 4 December 1999. It had previously been fitted to HL-7451, again in the No 1 position, but was removed on 23 October 1999 following a crew report of a problem during the 'align' sequence, together with an action/malfunction code of 4-07. The defect was confirmed in the workshops and the corrective actions were recorded as: "Replaced transformer T15 and IC Z13 on the Analogue to Digital Frequency Multiplex Board", and "Replaced Operational Amplifier AR2 and AR3 in the Frequency Continuity Board". (NB: these are unrelated to the attitude interface and attitude repeater boards.) Time since last repair was recorded as 269 hours. The unit was then refitted to HL-7451 on 4 December 1999 following an INU No 1 problem. There were no subsequent technical log entries relating to the INUs.

#### 1.6.5 Weight and balance

Maximum Take-Off Weight Authorised	820,000 lb
Estimated Take-Off Weight	548,352 lb
Maximum permitted Zero Fuel Weight	590,000 lb
Estimated Zero Fuel Weight	480,052 lb
Total Cargo Weight	140,452 lb

Estimated fuel on board at Take-Off	68,300 lb
Centre of Gravity limits at Take-Off	10.8 to 33% MAC
Estimated Centre of Gravity at Take-Off	22.3% MAC

### 1.6.5.1 Cargo details

The aircraft had initially been loaded with cargo at Kimpo Airport, South Korea. It had flown to Tashkent, Uzbekistan where there was a crew change and fuel was uplifted; no cargo was on/off-loaded at Tashkent. At London Stansted Airport, nine cargo palletes, weighing a total of 33,441 lb were off-loaded. This left a total on board of eight cargo palletes, weighing a total of 40,529 lb.

For the subsequent flight to Milan (Malpensa) Airport, Italy, additional cargo loads had been prepared by the Cargo Service Centre based at London Heathrow Airport. This cargo, comprising of 15 palletes and weighing a total of 99,923 lb was transported in four secure trucks to Stansted. It was then loaded onto HL-7451 and, in accordance with normal procedures, the load sheet was presented to the commander for checking and signing. The load was correctly calculated and distributed and the load sheet was correctly completed.

### 1.6.5.2 Dangerous Goods

The broad principles governing the international transport of Dangerous Goods (DG) by air are contained in Annex 18 to the Convention on International Civil Aviation, 'The Safe Transport of Dangerous Goods by Air'. An ICAO publication, '*Technical Instructions For The Safe Transport of Dangerous Goods by Air*', contains all the detailed instructions necessary. Additionally, The International Air Transport Association (IATA) produce an annual publication: '*Dangerous Goods Regulations*'. This publication is based on the ICAO regulations and constitutes a manual of industry carrier regulations to be followed by all IATA member airlines.

Both the Republic of South Korea and the United Kingdom are contracting members to the ICAO Standards; additionally, Korean Air is an active member of IATA. As a member of ICAO, the UK requires non-UK registered aircraft, to have prior permission from the UK CAA before transporting DG to or from the UK. This authority was renewed by the UK CAA to Korean Air under 10A/GF/79 dated 16 December 1998.

Two pallets (PMC-89769KE and PMC-51353KE), within the cargo on HL-7451, contained some DG. Both these pallets, loaded at London Stansted Airport, were designated to be carried on cargo aircraft only and contained the following items of DG: 35.4 litres of flammable liquid and toxic substance; 2 kg of solids; 2.39 kg of explosives (comprising components for military aircraft ejection systems, including detonating cords). The required 'Special Load Notification To Captain' containing information on the DG had been correctly completed and presented to the commander.

ICAO Technical Instructions Part 5 (Part 7 in the 2003-2004 edition), chapter 4.6.1 required that, '*The operator of an aircraft carrying dangerous goods which is involved in an aircraft accident must, as soon as possible, inform the State in which the aircraft accident occurred of the dangerous goods carried together with their proper shipping names, class and subsidiary risks for which labels are required, the compatibility group for Class 1 and the quantity and location on board the aircraft.*' In the accident involving HL-7451, the AAIB quickly ascertained the existence and description of the DG from the cargo loading company at Stansted. This would not have been so readily achieved if the accident had involved an aircraft inbound to the UK.

In the accident involving HL-7451, there was no indication of any action by the operator to comply with the ICAO requirement. However, the wording of the requirement was such that it would have been difficult for an operator to address the information to those who needed it, as there was no direction on who to contact in the State where the accident occurred.

In addition to the declared DG, there was other hazardous material in the cargo which did not fall into the category classified as DG and therefore required no specific DG packing or marking. This was a consignment of medical diagnostic kits containing small phials of 'Iodine 125' classified as 'Radioactive - Excepted Package'. Information on this material was not identified for several days because of the large volume and variety of paperwork associated with the cargo load.

## **1.6.6 Hazardous Materials**

### **1.6.6.1 Depleted Uranium**

HL-7451 was typical of early Boeing 747 aircraft in that Depleted Uranium (DU) mass balance weights were fitted in the outboard elevators and upper rudder. This material was selected for its high density, allowing sufficient mass to be installed with relatively low volume.

The depleted uranium used in the weights was clad with thin layers of nickel and cadmium and then painted with a primer and a top coat. If the clad layer is sufficiently damaged by fire or corrosion, small amounts of removable uranium oxide can result. The primary hazard from the oxide is the potential for internal exposure. This would require intimate contact with the oxide, transferring it to the mouth from contaminated hands for example.

Separate studies by Boeing and the US Army have shown that no danger exists from the DU balance weights in the event of an aircraft crash. The studies conclude that a fire in the tail section of the airplane of sufficiently high temperature and duration to generate significant amounts of airborne uranium is unlikely if not impossible. In addition, due to dilution and dispersion, concentrations of airborne uranium in the general environment would be less than the maximum allowable levels for long term exposure.

There was no evidence of any sustained fire of sufficient intensity to have 'burnt' the DU weights anywhere on the Stansted accident site.

The aircraft was built with twenty DU weights installed, six on each outer elevator and eight on the upper rudder. Throughout the site activity measures were employed to search for and remove the DU weights. All of the weights bar one were identified and disposed of during the aircraft recovery and site reclamation process. A detailed sampling and analysis programme of the site soil and the lake water failed to identify any traces of DU.

### **1.6.6.2 Aircraft structural, system and furnishing materials**

Some of the materials used in aircraft manufacture can be mixed and modified in an aircraft impact and fire to produce compounds, which present a hazard to those working on the accident site.

Following on from discussions at the meeting of the ICAO Accident Investigation and Prevention (AIG) Divisional Meeting (1999), the ICAO Hazards at Accident Sites Study Group has been tasked with developing a system for:

- gathering and disseminating information on hazardous materials and the risks they pose in air accidents investigation, and;
- providing guidance on measures to control, reduce or eliminate these risks.

This project has been established under the authority of the ICAO Accident Investigation and Prevention (AIG) Divisional Meeting (1999), and as such the system developed would be intended for the benefit of air accidents investigators. However, it is inconceivable that the system would not also be used for the benefit of all organisations responding to air accidents.

It was anticipated that the work of the study group would be completed within two years.

## 1.7 Meteorological information

Subsequent to the accident, the Meteorological Office at Bracknell provided an aftercast of the weather situation at 1830 hrs on 22 December 1999. The synoptic situation showed a strong, mild and very moist south-westerly airstream over the area. A Warm Front was lying just to the west of Stansted Airport, moving quickly eastwards. A strong wind warning was in force at the time of the accident. The aftercast also stated that between 1800 hrs and 1900 hrs the 2,000 feet wind was approximately 220°/55 kt with the 3,000 feet wind being similar though marginally stronger. Wind shear would have been significant and a wind shear forecast was in force for London Heathrow (the only airport in SE England that receives such a forecast) at the time of the accident. Low level turbulence would have been categorised as moderate, isolated severe.

The METARs (Meteorological Actual Reports) for Stansted were as follows:

1820 hrs: Surface wind of 190°/16 kt; visibility of 3,100 metres in mist; cloud few at 400 feet agl and scattered at 500 feet agl; temperature 10°C/dew point 9°C; QNH 1008 hpa.

1850 hrs: Surface wind of 190°/17 kt; visibility of 4,200 metres in mist; cloud scattered 500 feet agl, scattered at 600 feet agl and broken at 900 feet agl; temperature 10°C/dew point 9°C; QNH 1008 hpa.

On the initial call to ATC, the crew operating KAL 8509, the inbound flight to Stansted, reported that they had received ATIS information 'Mike'. The reported surface wind was 180°/17 kt; visibility 5,000 metres; cloud scattered at 500 feet agl and broken at 700 feet agl; temperature 9°C/dew point 8°C; QNH 1008 hpa.

Other flight crews, who were in the area close to the time of the accident, were contacted to confirm the weather conditions. All stated that the weather was as reported, but some pilots in medium sized aircraft experienced turbulence. Two remarks by the commander, recorded on the CVR, indicated that there had been precipitation some time prior to pushback, resulting in the commander raising concern that the ramp area and the runway surface could be slippery.

The official sunset time for Stansted was 1551 hours, with the end of civil twilight at 1621 hours.

## 1.8 Aids to navigation

The crew were using 'Jeppesen' charts. They had received a 'Charter Briefing and De-briefing Sheet' from their company prior to departing from Seoul. This included information on Stansted including the type of departure, which was correctly detailed as a Dover 6 Romeo. The navigation aids relevant to the designated departure were detailed in the UK Aeronautical Information Publication (UK AIP). These comprised Distance Measuring Equipment (DME), frequency Channel 42X located at Stansted Airport and two Very High Frequency Omni Ranges (VORs) located at Barkway (BKY frequency 116.25 MHz), positioned to the northwest of Stansted and Detling (DET frequency 117.3 MHz), positioned to the southeast of Stansted.

The Stansted aerodrome chart included in the UK AIP stated that the DME was frequency paired with ILS I-SED (Runway 05) and ILS I-SX (Runway 23); The ILS chart stated that DME I-SX zero ranged to THR RWY 23. The UK AIP also includes master details of Standard Instrument Departures (SIDs) and ILS procedures. 'Jeppesen' publications base their charts on information from the AIP. The Dover 6 Romeo SID and ILS/DME procedures for Runway 23 from the AIP, and 'Jeppesen' are included as Appendix F, Figures 1, 2 and 3. The relevant aspects are detailed below:

1. *Dover 6 Romeo SID*. None of the pages from either of the two publications included any comment relating to the position of the DME zero range and the DME is illustrated on both publications as being close to the mid-point of the runway. Each described the initial procedure as 'Straight ahead to I-SX D1.5 (BKY R152)' and then a left turn. The AIP included an airborne frequency of 118.82 Mhz whereas the 'Jeppesen' page detailed that the frequency would be allocated by ATC.
2. *ILS/DME Runway 23*. Both publications included information that DME I-SX was zero ranged to the threshold of Runway 23. The AIP requires an aircraft on a go-around to turn right at 'VOR BKY R161 (I-SX DME 2.9)'. 'Jeppesen' has a slight difference in presentation in that it requires the aircraft to turn at 'D2.9 I-SX/ R-161 BKY VOR'.

The Stansted DME was replaced in January of 1999 when a Fernau 1020 DME unit was removed and a Fernau 2020 DME installed. The Fernau 2020 equipment has been in use in the UK for a number of years with no record of major failings.

The Dover 6R SID requires aircraft to commence a turn at 1.5 nm on the Stansted DME to accommodate noise abatement over the village of Great Hallingbury. Both publications contained the following: '**WARNING - STEPPED CLIMB:** Due to interaction with other routes pilots must ensure strict compliance with the specified climb profile unless cleared by ATC' and a note that 'SIDs include noise preferential routes'.

The DME will be unusable by an aircraft rolling down the runway due to the proximity of physical obstacles. There have been a number of flight tests of the Stansted DME since the accident and some modifications to improve performance but no deficiencies in performance were identified to affect aircraft on a Dover 6R SID.

## 1.9 Communications

### 1.9.1 R/T Transmissions

Stansted Ground and Tower frequencies were both recorded by equipment installed in the Stansted control tower. The tape was impounded after the accident, replayed and a transcript produced.

The tape revealed that at 1727 hrs the crew of KAL 8509 attempted to contact Stansted Delivery on 125.550 MHz to obtain their departure clearance. This frequency however was not manned thus the crew called the Stansted Ground controller for their clearance. The ground controller did not have any details on the KAL flight and therefore suggested that the crew make contact with their handling agent to resolve the situation. By 1742 hrs ATC were able to pass to the crew their clearance which was, "CLEARED TO MILAN MALPENSA VIA A DOVER SIX ROMEO, SQUAWK TWO TWO THREE ZERO". The crew read back their clearance correctly. At 1806 hrs the crew requested clearance to pushback and start, ATC however transmitted that there would be a five minute delay due to another aircraft about to taxi behind them.

At 1813:30 hrs they were given pushback and start clearance from Stand No 6. Four and a half minutes later, at 1818 hrs, it became apparent to the ground controller that the aircraft was having difficulty in pushing back. He asked if there was a problem and was informed by the commander that they were having a problem with the tug which appeared to have insufficient power to perform the task. During the course of the pushback, which included the engine start sequence, until just before the request for taxi by the first officer, the commander handled all radio communications with both the tug driver and ATC.

The tug driver, who was also operating on the ground frequency then contacted the ground controller stating that the tug had "RUN OUT OF POWER" and was it possible for a marshaller to be provided to marshal the aircraft onto the taxiway centreline from its present position. Eventually a marshaller arrived on the scene and, at 1827:30 hrs, KAL 8509 commenced taxiing via Taxiway 'H' to holding point 'HN' for Runway 23 and was transferred to the tower frequency of 123.800 MHz.

The crew checked in on the tower frequency and were instructed by the tower controller to "HOLD AT HOTEL PAPA (HP) THAT'S THE SECOND HOLDING POINT". The crew of KAL 8509 transmitted that they were "READY FOR TAKEOFF" at 1834:30 hrs. The controller cleared the aircraft to line up behind a landing aircraft at 1835 hrs and at 1836:30 hrs, having passed the surface wind of 190°/18 kt, cleared the aircraft for takeoff. The controller did not, and was not required to, pre-warn the crew of the London frequency they would be allocated after departure. At 1838 hrs the tower controller instructed the crew of KAL 8509 to "CONTACT LONDON ONE ONE EIGHT DECIMAL EIGHT TWO GOODNIGHT". The first officer correctly read back the frequency change. This was the last transmission recorded from KAL 8509. No transmission from the crew was recorded on the London frequency.

### 1.9.2 Radar recordings

The progress of the flight, detected by the Stansted Watchman and Debden radars was recorded at the London Air Traffic Control Centre (LATCC). Based on the transponder setting of 2230 with mode C selected, the first return was just past the mid-point of the runway indicating a height of 660 feet amsl (airport elevation 348 feet amsl). At the end of the runway, the aircraft was at approximately 1,200 feet amsl. It maintained a track close to the extended runway centre-line before turning to the left. The radar returns cover a period from 1837.46 hrs to 1838.36 hrs. The last return indicated a height of 1,060 feet amsl. The maximum height achieved was recorded as 2,460 feet amsl and the rate of descent, from the highest point to the last return exceeded 5,000 feet per minute. Additionally, the ground speed increased after the highest point achieved, with the maximum speed calculated to be 228 kt over the last two radar returns. The southerly wind and the aircraft change in heading from south-west, through south to east, would have affected the ground speed.



### **1.9.3 Navigation Radio Setup**

It would have been normal company procedure for the commander to set 110.5 I-SX on VHF Nav Radio No 1 for the DME readout. The first officer appears to have initially set 117.3 MHz (DET) on VHF Nav Radio No 2, until the commander's instruction to set 110.5 MHz to check the DME indication. It is not known whether the first officer reset the 'DET' VOR frequency on his Nav Radio prior to takeoff.

## **1.10 Aerodrome information**

### **1.10.1 Runway physical characteristics**

The aircraft departed Stansted from Runway 23 which is 3,048 metres (10,000 feet) in length and 46 metres (151 feet) wide and has a QDM of 226°M and an asphalt surface. The full length is available for takeoff. Runway 23 threshold has an elevation of 348 feet whereas the elevation of the departure end (Runway 05 threshold) is 324 feet (see Appendix F, Figure 4).

At the time of the accident the runway was wet but with a braking action categorised as 'good'.

### **1.10.2 Lighting**

The runway is equipped with high intensity flush edge lights and high intensity bi-directional centre-line lights. The threshold is marked by high intensity green lights with green wing bars. At the time HL-7451 took off the runway centreline and edge lights were set to an intensity of 10%.

## **1.11 Flight recorders**

### **1.11.1 Flight data recorder (FDR)**

The aircraft was equipped with a Sundstrand Universal Flight Data Recorder (UFDR) with a recording duration of 25 hours using magnetic tape as the recording medium. The UFDR consists of a chassis assembly connected to the front panel, to which is attached an underwater locator beacon (ULB), and the unit is covered by a standard 1/2 ATR long dust cover. Within the chassis is the tape transport assembly, protected by a thermal and impact resistant enclosure, an external stepper drive motor and a number of electronic cards. The enclosure consists of two halves of hardened steel outer shell with a fibre glass liner. It is mounted to the front panel and chassis assembly with four vibration isolators.

The crash protected thermal enclosure containing the tape was found in the impact crater one week after the accident. It had become separated from the rest of the unit that was also found within the crater. The ULB was found completely detached approximately 10 metres from the edge of the crater. The front panel was never found. Appendix G, Figure 1 shows the damage. The enclosure itself had suffered an impact severe enough to break two of the bolts that secure the two halves of the enclosure together, allowing partial separation (see Appendix G, Figure 2). This could have allowed heat to penetrate the enclosure, but on examination the tape itself was essentially undamaged (Appendix G, Figure 3).

The tape was removed from the recorder and replayed on an 'open reel' system at the AAIB in Farnborough. A number of replays were performed, allowing all the data to be recovered from the 25 hour period. This covered the entire accident flight, and three previous flights.

The UFDR does not run continuously when it is recording. It stores data into one of two volatile memory stores, each holding one second of data. When one memory is full, the data flow is switched to the other store. While data is being fed to this other store, the tape is rewound and the previous second of recorded data is checked. A gap is left on the tape and the data from the first store is written to the tape, and the first memory is emptied. The data is preceded by a preamble sequence of datawords, and followed by a postamble sequence. The presence of the postamble bits indicate that the process of writing to the tape is complete. The whole 'checkstroke' operation takes much less than one second to complete so that once the second store is full, data is switched back to the first store, and the second store is written to the tape using the 'checkstroke' operation again. The procedure is then repeated. Thus, when power is removed in an accident, the data held in volatile memory in the recorder, which has not been recorded on the tape, is lost.

The data is recorded in one second 'subframes', each containing 64 data 'words'. The analogue waveform of the digital signal was analysed and the beginning of one more subframe was recovered, ending at word 4 of 64. No postamble bits were present, therefore the recorder was in the process of writing to the tape from the volatile memory when power was lost. The final recorded altitude was 1193 feet (on 1013 mb), 662 feet AAL, sampled in word 5 of the 64 word subframe, almost one second before the recording ended. By correlation with the CVR, the recording ends between one and two seconds before the accident.

The FDR takes data from the Flight Data Acquisition Unit (FDAU) located in the electronics bay at the front of the aircraft. It records 41 parameters including airspeed, altitude, heading, normal acceleration, pitch and roll attitude, control wheel position and 23 discrete parameters. The pitch and roll attitude information is taken from INU No 1, irrespective of the pilot selection for attitude information on the instrument. The data showed that for the accident flight and the previous flight from Tashkent into Stansted, only very small roll attitudes (less than 2°) were recorded, even during large heading/control wheel changes. On the two earlier flights roll attitude appeared normal and consistent with the heading changes performed by the aircraft.

### **1.11.2 Cockpit voice recorder (CVR)**

The aircraft was equipped with a Fairchild model A100 re-cycling CVR that records the latest 30 minutes of audio information on four tracks. The CVR, which had suffered much less damage than the FDR, was recovered from beside the impact crater on the night of the accident. Appendix G, Figure 4 shows the CVR unit as found.

The tape was removed and replayed by the AAIB. The recording covered the period from before engine start to the accident. The crew conversation was all recorded on the area microphone channel; conversation with ATC was recorded on the other three separate channels. The crew conversation was a mixture of English, used for the standard ATC calls and checklists, and Korean language. A full transcript was performed with the help of the KCAB except in two sections where the content was deemed non-pertinent.

On the CVR, the commander made a number of comments about the delays experienced. Around 10 minutes before takeoff, as the crew were completing the taxiing checklist, the commander commented that the DME display looked unreasonable, and asked if the first officer's instrument was showing the same. The commander questioned how they were going to identify the 1.5 DME turn. The flight engineer then commented that "NOW IT'S WORKING CORRECTLY".

The first officer made transmissions in response to the tower's taxi and line-up clearances. His responses were accurate but the commander made inappropriate cross-cockpit comments to the first officer to correct him. Furthermore on two other occasions, the commander spoke to the first officer in a manner, which was construed by Korean listeners as derogatory, stating on one occasion "MAKE SURE YOU UNDERSTAND WHAT GROUND CONTROL IS SAYING, BEFORE YOU SPEAK." AND, "ANSWER THEM! THEY'RE ASKING HOW LONG THE DELAY WILL BE".

During the delay, prior to the tower clearance for line-up and departure, verbal exchanges regarding the distance and travelling time between London and Stansted Airport suggest that the ground engineer was in the flight deck, seated in the jump seat immediately behind and to the left of the commander.

Appendix H contains translated extracts from the transcript beginning at the point where the crew receive their take-off clearance.

### **1.11.3 Audio analysis**

Shortly after takeoff there was an audio alert recorded on the CVR that was identified as the attitude comparator warning. Each of the attitude indicators has separate warning circuits with a nominal audio warning frequency of 2.9 kHz and a period of 1.5 Hz. The 1.5 Hz period is synchronised by an

oscillator that is common to both circuits. Each circuit exhibited a slightly different frequency from the nominal 2.9 kHz thus it was possible to identify whether one or both were operating.

Both warnings initially activated 16.7 seconds after takeoff and were active for two brief periods. Both warnings were re-activated 32.7 seconds after takeoff, 23.9 seconds before the end of the recording and one remained on for four cycles, and the second carried on for a further five cycles, and was ended in mid tone on the tenth.

From correlation with the FDR the two initial brief warnings stopped as the aircraft rolled back to within the four degree instrument warning tolerance, thus cancelling the warning condition. As the aircraft began to roll left continuously the warning activated and the cancellation mid-tone suggested that the warning was cancelled by the crew. It was not possible to differentiate which warning came from which side of the flight deck, and thus determine which pilot had cancelled the warning first.

#### 1.11.4 Simulation

The probable roll profile of the aircraft was determined with the support of the aircraft manufacturer through the use of their engineering simulator (M-cab) based in Seattle, and analysis of the available FDR and radar data. The 'M-cab' is a full motion engineering simulator capable of being flown either from the simulator flight deck, or from data inputs. The 'M-cab' was configured with a standard 747-200F aircraft layout with JT9D-7Q engines, including a four engine throttle quadrant and EPR engine gauges mounted on the centre panel. There was a Collins ADI on each of the captain's and first officer's instrument panels, however there was no standby attitude indicator fitted.

Due to the low FDR sample rates a 'mathematical pilot' was used while running the desktop simulator to determine the flight control positions needed to produce the recorded flight profile and derive the probable roll attitude profile. This used mathematical equations to modify control inputs to account for differences between the generic simulator and the actual aircraft, as well as limitations in the basic FDR data. These flight control inputs were then used to backdrive the 'M-cab' engineering simulator.

Two different setups were available:

##### *Full backdrive*

For this profile the 'M-cab' was initialised at a point in the initial climb, prior to any deviations from wings level flight. The Engine EPR was adjusted to a trim setting and the profile was flown by driving the simulator flight control inputs with the derived control column, control wheel and rudder pedal inputs from the mathematical pilot simulation. The stabiliser was driven from the FDR data with a constant bias applied. This reproduced the accident flight path, with the actual derived roll attitude. All backdrive runs were identical and Appendix I, Figures 1 and 2 show this profile. There are two plots for each case, the first one in each case being a longitudinal axis plot and the second one a lateral axis plot.

##### *Backdrive with pilot interaction*

For this profile the backdrive as described above was flown, but the pilot could take over control of the simulation at any point by use of a switch on the overhead panel. The pilot was then free to attempt to recover the aircraft to a wings level attitude with positive climb, using the manual flight control inputs and techniques desired. The 'M-cab' then essentially operated as a normal flight simulator, producing the appropriate aircraft response to pilot inputs.

A number of runs were performed in this configuration in order to investigate the recovery possibilities. Appendix I details these runs. The initial runs (Case 1 and 2) demonstrated that the aircraft could recover from roll attitudes of 45° and 60°. Recovery from the peak altitude (from a roll attitude of 72° - Case 3) and then two seconds beyond this (from a roll attitude of 78° - Case 5) were then demonstrated. Appendix I, Figures 3/4 and 5/6 show Cases 3 and 5 respectively. Recoveries beyond this point were also demonstrated. The maximum normal acceleration seen during each recovery is noted in Appendix I. The aircraft limit load factor range with flaps down is 0 to +2g.

Those runs in which normal accelerations exceeded +2g could therefore have resulted in structural damage during the recovery.

### 1.11.5 Data interpretation

Appendix J contains data from the FDR for the period from the takeoff until the end of data, together with relevant comments from the CVR. The actual roll attitude quoted is that derived through 'M-cab' analysis described above.

The data showed that the takeoff was normal with a flap angle of 10° and the aircraft climbed initially on runway heading. Normal crew calls were made during the takeoff. The comparator warning first sounded 16.7 seconds after takeoff. At 1,294 feet pressure altitude (1,144 feet AAL) 19 seconds after takeoff, the commander said "WE SHOULD TURN AT 1.5 DME". He then said the "DME IS NOT WORKING". The comparator warning sounded again at this time. The first officer then called for a heading of 158°. At 1,936 feet pressure altitude (1,786 feet AAL), 29 seconds after takeoff, the control wheel position moved through approximately 30° to the left and the aircraft commenced a left turn. The comparator warning sounded 32.7 seconds after takeoff and ended 6 seconds later, mid tone.

The flight engineer called '*BANK IS NOT WORKING*' (italics denote translation from Korean language), 26 seconds after takeoff, when the derived roll attitude was 46.5° to the left. This coincided with the radio call from Stansted to change frequency, which was answered by the first officer. There were two brief reversals in Control Wheel position from 33.5° to 11°. The pitch attitude then started to decrease and continued to decrease until the end of data. The maximum pressure altitude attained was 2,645 feet (2,495 feet AAL), 43 seconds after takeoff and 12 seconds before the end of data.

The flight engineer said "STANDBY INDICATOR *ALSO NOT WORKING*" (italics denote translation from Korean language). (The third word could not conclusively be interpreted). At 2,235 feet AAL, 48 seconds after takeoff, the control wheel position moved back to neutral, as the heading passed through 167° (note: the heading target was 158°). No further significant movement of the control wheel occurred.

Fifty seconds after take-off, the commander requested radar vectors at which time the aircraft was descending through 1,950 feet AAL, with a derived roll attitude of 80.6° to the left.

The data ended 55 seconds after take-off. The final recorded altitude was 1,192 feet pressure altitude (1,042 feet AAL), at an airspeed of 262 kt, pitch attitude of 35.5°, nose down, heading of 114°M and a derived roll attitude of 72.3° to the left.

Appendix K shows the track from the recorded radar data.

## **1.12 Wreckage and impact information**

Because of the nature of the accident, the abundance of information derived from the two data recorders and witnesses, a decision was taken not to recover most of the wreckage. Therefore, all analysis of impact parameters and aircraft configuration was carried out on site with the assistance of representatives from the airframe and engine manufacturers.

### **1.12.1 Impact parameters**

The aircraft struck gently rising ground close to farm buildings and an ornamental lake at the edge of the village of Great Hallingbury, at position N 51° 51.35', E 000° 12.98', some 1.2 nm south of Stansted Airfield reference point. The aircraft's attitude was estimated to be some 40° nose down, banked left at an angle of bank of between 80° and 90° (see Appendix L, Figure 1). Speed at impact was estimated at between 250 kt and 300 kt. The aircraft's track at impact was measured at 102°M. An initial assessment suggested that all four engines had been producing power at impact. The aircraft wreckage was distributed most densely in, and immediately beyond, the impact crater (see Appendix L, Figure 2). The area bordering the lake contained large sections, mostly from the rear of the aircraft, the engines and the landing gear. Items located towards the front of the aircraft, particularly components from the forward electronic and equipment (E&E) bay and the cockpit, had generally suffered extreme impact damage, with only a minor proportion being recovered in a recognisable form. The wide variety of cargo being transported by the aircraft was scattered throughout the wreckage trail.

### **1.12.2 Configuration**

At the time of impact the aircraft had been configured in the expected post take-off configuration with the landing gear retracted, the trailing edge flaps set at 10° and the leading edge flaps/slats extended. The nature of the impact damage to the ground, wreckage distribution and the absence of any components from this aircraft being found along the taxiways or runway at the Airport or along the aircraft's ground track, all indicated that the aircraft had been complete and structurally intact at the time of impact.

### **1.12.3 Powerplants**

All four engines suffered massive frontal impact and a high degree of physical disruption. Two of the engines (Nos 1 and 2) were found within the main crater formed by the left wing and fuselage centre section. The remaining two engines (Nos 3 and 4) had been thrown beyond the crater. The identity of each engine, and thus its position on the aircraft, was positively confirmed by serial numbers etched on individual fan blades extracted from the fan hubs at the site. These blade serial numbers were provided to the operator who was able, from maintenance records, to identify the serial number of each engine.

None of the engines had remained structurally intact in the impact and all four engines displayed similar magnitudes of damage. This was found both in the overall level of disruption and in the characteristic patterns of damage found in areas such as the 'rubstrips', which surround the HPT (high-pressure turbine) blades.

All four engines showed rubbing and scoring damage that was consistent with high rotor speed at the time of impact. There was no metal impingement (splatter) noted in any of the engines that would indicate any disruption of the gas path prior to impact. Because of the massive damage to all four engines, the possibility of some minor mechanical defect could not be entirely discounted but there was no evidence of any such defect and no evidence that it affected the operation of the engines.

The engine manufacturer was asked to examine the FDR data for the engines to determine whether the data was consistent with predicted engine performance for the recorded flight conditions. This analysis concluded that the performance was within the manufacturer's expectations throughout the

flight. There was no evidence in the FDR data of engine surge or other disruption that might account for an eyewitness account of fire at one of the engines momentarily before impact. However, the manufacturer did comment that it was possible that such a surge could have occurred in the final 1.6 seconds (see paragraph 1.11.1) between the final FDR record and the impact with the ground. This could have been consistent with the extreme aircraft attitude, and possible distortion of the inlet airflow, just before impact.

#### **1.12.4 ADI/FDI wreckage**

Despite an exhaustive search of the accident site only one relatively complete, but severely damaged, ADI was recovered and a view of its front face is shown in Appendix M, Figure 1. The backplate of another unit, complete with data plate, was also recovered attached by wires to some internal components. The serial number, 5D2193, identified this backplate as belonging to the spare ADI from the 'fly away kit' carried on board the aircraft, thus indicating the more complete unit recovered as one of the two fitted to the instrument panels in the cockpit.

##### **1.12.4.1 ADI Examination**

Initial visual examination of the ADI revealed deformation to the rear of the unit consistent with an aircraft impact attitude of some 40° nose down and a roll angle of some 80° to 90° to the left. Although severely crushed, the body of this unit was largely complete and contained within the casing almost all of the mechanical and electronic components. However, most of the delicate warning flags and indicators, together with the lower section of the attitude tape and its support frame, were missing from the front of the instrument. The backplate, containing both electrical connectors, was also missing. From this initial examination the 'as found' position of the attitude tape frame suggested that this ADI had been displaying a low angle of bank at the time of impact with the ground.

The unit was taken to the manufacturer's facility at Cedar Rapids, Iowa, in the United States where a strip examination was carried out in the presence of representatives of the AAIB, the manufacturer, the KCAB and Korean Air. The severity of the damage to this unit was such that no functional testing could be carried out. Once the outer casing had been removed, visual examination of the unit's internal components revealed no apparent evidence of pre-impact defect or failure. During the strip the code 8E461 was found written in marker pen ink on the rear of the upper section of the fixed bezel, a practise not normally used by the manufacturer during initial build. The operator's records indicated that an ADI with this serial number had been fitted at the captain's position on HL-7451, in June 1999, after being serviced in their instrument workshops.

The roll attitude presented at the time of impact was assessed, from the position of the attitude tape casting relative to the internal structure, as being approximately 7° to the left, after making some allowances for impact related distortion of the instrument. As there was no evidence to suggest that the roll attitude mechanism had been forcibly rotated to this 'as found' position, and in consideration that any distortion applied to this unit during the impact would be very likely to cause the mechanisms to jam, this 7° value was considered to be a reasonably good indication of the displayed roll attitude at impact.

Examination of the pitch attitude tape revealed that only the light blue 'sky' section, from around 30° to 90° pitch up, remained wrapped around the upper spool, the remainder having been torn away. This section of tape, the lower section of the attitude tape casting and the lower spool were not recovered. The 'as found' position of the tape, when reproduced on a serviceable ADI, was consistent with a nose up pitch attitude of some 9°.

##### **1.12.4.2 Command bar position**

The support pillars and wires for the two command bars (yellow items in Appendix B, Figure 1) had remained attached to their support/operating mechanism. In normal operation the displacement of the command bars, with respect to the aircraft reference symbol, are limited by either the steering computer, the ADI or both. The roll command is limited electrically to 20° left or right, which is

slightly less than the mechanical stop position, and the pitch command to 7° nose down and approximately 15° nose up. Whenever the out-of-view bias voltage is applied, the command bars move past the electrical limit to park out of view.

The 'as found' position of the flight director command bars was established during the strip examination by a pair of levers which support the (yellow) bars. These were found jammed as a result of the impact in an upward and clockwise rotated position, similar to the position of command bars when directed to display the maximum fly up and fly right command.

Analysis of the 'as-found' position carried out during the strip examination suggested that the command bars were in view at the time of the accident and that they had been displaying a pitch up and a fly right command of some 15° and 20° respectively. No evidence was seen to indicate that this mechanism had been forcibly moved to this position during the impact.

#### **1.12.4.3 Gyro flag position**

At the start of the strip examination of the captain's ADI, the crushed casing was slowly sectioned to facilitate removal. During this process the gyro flag was found entrapped within the folds of the left vertical section of the case (viewed from the front), as shown in Appendix M, Figure 5. An attempt was made to compare this position on a serviceable unit, in Appendix M, Figures 3, 4 and 6, with its normal deployed and retracted positions. When retracted (out of view) the flag is positioned close to the left wall of the casing and is protected to some extent behind the front bezel. The best estimate of the flag position at impact that could be made, considering the highly deformed nature of the casing, was that it had been out of view at the time.

The torque motor that drives this flag is similar in nature to the meter movement of an ammeter or voltmeter. This motor, and a large section of the fine flag support tube which it drives, remained loosely attached within the wreckage of this ADI. It was apparent that the armature of this movement was positioned close to the 'non powered - flag in view' end of its travel, but also that it remained partially free to move.

#### **1.12.4.4 Standby Horizon**

The standby attitude indicator is an independent unit, which contains its own gyro, and which is powered from the aircraft's 28V DC Battery Bus through a three phase 115V 400Hz static inverter. It is located towards the top of the panel and immediately to the right of the captain's flight instruments, Appendix Q, but its display is smaller than that of the ADI and solely indicates the aircraft's attitude in pitch and roll. When running and erect, the gyro remains aligned with 'earth' axes, whilst the instrument casing is always aligned with the aircraft axes. When the aircraft is in level flight these two sets of axes, approximately, co-incide and thus the aircraft's roll and pitch attitude presented to the flight crew should always be referenced to a true horizon and a true vertical axis. Thus, if an aircraft adopts a co-incident 90° roll and a 40° nose low attitude, the gyro driven attitude instrument would indicate a 40° pitch down in earth axes, despite this not being a pitch attitude in aircraft axes.

The internal mechanism is typical of such instruments in that the gyro is mounted within a cage, which is supported by bearings on its longitudinal axis in such a way that allows the casing to rotate relative to the cage. The indication screen is attached to the front of the cage in such a way that, as the aircraft rolls, it directly indicates an angle of bank. In order to present pitch information to the crew in the natural sense, a reversing mechanism is used, driven from the relative changes in attitude between the gyro and the cage, to move the indication screen up and down and thus indicate pitch attitude relative to earth axes.

The standby attitude instrument was not recovered from the accident site during the immediate post-accident period but the front section, ie, that part containing the pitch and roll screen visible to the crew, was found, by chance, approximately one year later in Hatfield Forest. Although this section was relatively complete, the casing had been distorted in the impact such that the screen was locked to the casing. The 'as found' indications were, approximately, 90° of roll to the left and 5° of nose-up



pitch. Detailed examination of the scuff marks between the indication screen and casing suggested that whilst the screen had little relative movement to the case, in the roll sense, during the impact, the screen had been moving in a pitch-up sense as the two came into contact. It was considered most likely that as the rear section of the indicator was torn from the front section, the reversing mechanism imparted a false movement to the pitch position of the screen, and thus the 'as found' pitch indication was likely to be unreliable data.

### **1.13 Medical and pathological information**

Post mortem examinations were carried out on the three flight deck crew members and the ground engineer. Identification of the bodies proved difficult and fingerprints and DNA technology had to be used to complete the identification.

It was not possible to determine if there was any evidence of any pre-existing disease, alcohol, drugs or any toxic substance that may have contributed to the cause of the accident.

The pathological report stated that despite the severe injuries sustained it was possible to determine that the first officer's right hand had a laceration of the sort that is frequently seen in pilots who have their hands on the control column at the time of impact. The report therefore concluded that it was possible that the first officer had his hand on the control column at impact.

### **1.14 Fire**

Examination of the accident site showed clear evidence that when the aircraft struck the ground a large volume of fuel had been released, which had then ignited and formed a fireball. This had scorched and deposited soot on some areas of the ground, trees and wreckage for a distance of some 500 metres from the impact crater and had drawn up many fragments of lightweight debris into the air. This debris was distributed downwind from the accident site and deposited as far away as the runway at Stansted Airport. Although various items of wreckage that had been soaked in fuel, for example tyres and flammable cargo, continued to burn on the ground for some time after the accident, the majority of wreckage in the affected area was only heavily sooted. There was no evidence of pre-accident (airborne) fire or explosion identified in the wreckage.

### **1.15 Survival aspects**

The accident was non-survivable.

## 1.16 Tests and research

### 1.16.1 ADI/FDI tests

The roll attitude input to the ADI is a three wire (X, Y, Z) synchro signal. Under normal conditions the amplitude of the 400 Hz AC voltage on lines X and Y, with respect to Z, varies as the sine of the roll attitude, with a 120° phase difference between them. Tests were carried out by the manufacturer on a similar INU to that fitted to HL-7451, in which the unit was functioned in a fully serviceable condition and with postulated failures incorporated. The results produced a series of measured values of rms voltages for the roll attitude X, Y and Z lines, at roll angles between 0° and 90°. These data were passed to Rockwell Collins and used to simulate the roll attitude input signal to an ADI. The abnormal condition evaluated was one where the amplitudes of the signals on lines X and Y, with respect to Z, were equal for all roll angles, but where this amplitude and not the difference between X and Y varied with roll angle.

For these tests, a test fixture (Collins Part No 637-7680-001) and an audio signal generator (SG) were connected to a Collins 329B-8J-005 ADI. Although the test unit was a -005 model, with respect to the attitude display it performed in the same manner as the -001 model. To facilitate testing, the roll attitude X, Y and Z inputs lines to the ADI were segregated out from the interconnecting cable. With 11.8V rms applied by the SG to lines X and Y with respect to Z (the normal voltage to be expected at 0° roll angle but with a phase difference of 120°), the roll attitude became unstable and erratic, oscillating from > 90° left to > 90° right. The gyro flag remained in view. Little effort was required to hold the attitude display mechanism at 0° and when this was done, the gyro flag was not in view. Under this condition, however, the flag dropped into view when the applied voltage was reduced to 4V rms.

Collins later considered that the test may not have been truly representative as this oscillating may have been due to some noise brought about by the *ad hoc* nature of the test set up. There could also have been some imbalance between X and Y phase and amplitude.

As a result of this finding, a second test was conducted without the use of a signal generator, but with the test fixture interconnect restored to normal and a jumper lead connected between lines X and Y. In this test, with the input roll attitude set at 0°, the displayed attitude remained at 0° and the gyro flag was not in view. As the input roll attitude was varied in either direction, the displayed attitude remained at 0° and the flag stayed out of view. As the test set attitude input approached 180° the display flipped over to show 180° of roll, which it continued to show until the input attitude was returned towards 0° at which point it flipped back to show 0° of roll. The gyro flag briefly dropped into view each time the display flipped over.

Further tests were conducted by introducing resistive shorts between the 'X' and 'Y' lines in an attempt to reproduce the small response in roll just prior to impact, as indicated by the FDR, rather than no response as mentioned above. Analysis of the FDR data suggested that an output which peaked at around 2° was in response to roll rate, rather than bank angle, during the final turn to the left.

### 1.16.2 INU tests and research

The crew report of the failure of the captain's flight director indicator in roll during the flight from Tashkent to Stansted, plus the FDR indication of near zero roll angles for the entire flight, provided conclusive evidence of a problem with INU No 1. This was reinforced by the fact that the indications became normal following the commander's selection of his ATT/COMP/STAB switch to ALT, thereby sourcing the attitude signals from INU No 3. The Roll 1 (captain's flight director indicator) and Roll 3 (FDR) are carried on separate wiring from different output pins on INU No 1, indicating that both Roll 1 and Roll 3 signals were corrupted. Bearing in mind that all roll output signals are generated from a single synchro input, it seemed probable that all the other roll outputs may have been similarly affected. This led to the supposition that a common mode failure, in the form of a short

circuit, may have occurred upstream of the roll amplifiers in either the attitude interface or the attitude repeater. In the absence of any identifiable wreckage from the INUs it was not possible however to confirm this.

The probable positions of the short circuits are indicated on the schematic diagram at Appendix E, Figure 3. Litton Aero Products were tasked with conducting a laboratory test with an intact INU mounted on a tilt table, in which the short circuit conditions had been deliberately introduced. Initially, the sine signal line was grounded (position 'A' in Appendix E, Figure 3) and the outputs of all five channels were measured for a range of actual angles of the INU. The results were that the output values varied only from 0.02° to a maximum of 0.08° over the range of input bank angles of 0 - 90°. At 60° and above, Primary and Auxiliary warnings were generated.

The tests were then repeated with a resistive path between the sine signal line and earth. The value of the resistance varied from 5 to 1,000 ohms. The results were similar to before, except that the output roll angles increased slightly at higher resistances. For example, a platform angle of 60° resulted in output angles of 1.16, 2.35 and 4.62° for resistances of 25, 50 and 100 ohms respectively. Once again, Primary and Auxiliary warnings occurred at 60° and beyond. When the resistances, however, were increased to 500 and then 1,000 ohms, warnings were not triggered until 70 and 80° respectively.

Further tests explored potential failure modes of a short circuit between the combinations of 3-wire synchro signals from the roll gyro (site 'B' in Appendix E Figure 3). The combinations were thus X-Y, X-Z and Y-Z. The results, which are summarised below, differed according to whether the platform was rolled left or right.

*a) INU rolled right*

Platform angle	X-Y	X-Z	Y-Z
0 - 20°	0°	Appx 60° right	Appx 60° left
30°	Appx 0°	Appx 60° right	4° left
40 - 90°	0 - 1.5° right	Appx 60° right	Appx 120° right

*b) INU rolled left*

Platform angle	X-Y	X-Z	Y-Z
0 - 30°	0°	Appx 60° right	Appx 60° left
30°	0°	No value	Appx 60° left
40 - 90°	0 - 1.5° left	Appx 120° left	Appx 60° left

The Primary and Auxiliary warnings were set for the X-Y short at INU angles in excess of 60°. There was a more random spread of warnings for the X-Z and the Y-Z conditions.

A review of the FDR data for the accident flight showed that the maximum recorded left roll angles (which represented the Roll 3 outputs) were 2.46° at one data point, 1.76° for another and 1.05° for two data points. The remaining data points showed roll angles of less than one degree. The maximum recorded roll angle occurred when the aircraft was actually banked at around 60°, as derived from the 'M-cab' simulation described in paragraph 1.11.4. Comparison with the above test results would seem to exclude the X-Z and Y-Z synchro wire short conditions. Litton Aero Products considered that the nearest correlation to the FDR data would be a resistive path of 30-40 ohms from the sine signal wire to ground.

## **1.17 Organisational and Management Information**

### **1.17.1 Korean Ministry of Construction and Transportation (MOCT)**

The Ministry of Construction and Transportation has the authority to regulate and the responsibility for aviation safety. The responsibility had been delegated to the Director General of the Civil Aviation Bureau (KCAB), two Administrators of the Regional Aviation Administrations (Seoul and Pusan) and the Administrator of the Korea Area Traffic Control Centre. (On 12 August 2002, the Civil Aviation Bureau was reorganised under a newly established Korea Civil Aviation Safety Authority (K-CASA).) Some of the duties however, were re-delegated to the Korean Transportation Safety Authority and Korea Airports Authority under the Aviation Act No 154. The Aviation Act deals with; general provisions (pursuant to ICAO Standards and recommended practices); aircraft; persons engaged in aviation; operation of aircraft; aviation facilities; air transport business; aircraft handling business; foreign aircraft; accident investigation; supplementary provisions and penal provisions.

The Civil Aviation Bureau had consisted of six divisions; Aviation Policy Division; Aviation Safety Division; Flight Operations and Certification Division; ATS and CNS / ATM Division; Airport Facilities Division and the International Air Transport Division. The Aviation division is sub-divided into departments responsible for Flight Safety Planning, Flight Safety Oversight and Accident Prevention and Investigation.

The KCAB reorganisation in 2002 also resulted in the formation of the Korea Aviation Accident Investigation Board (KIAB). Organised under the Aviation Act No 152.2 within the Ministry, but separated from the newly established K-CASA, the KIAB is an independent aircraft accident investigation authority consistent with ICAO Annex 13 to the Convention on International Civil Aviation, Aircraft Accident and incident Investigation, Chapter 5.4:

The accident authority shall have independence in the conduct of the investigation and have unrestricted authority over its conduct, .....

### **1.17.2 KAL company organisation**

The company organisation is headed by the President and Chief Executive Officer (CEO). Under the CEO the company is split into six branches covering: maintenance and engineering; in-flight service; passenger traffic; cargo traffic; aerospace and flight operations. The flight operations department has at its head the Vice President Flight Operations who is also responsible for 'flight control' and 'corporate safety'. As of March 2000 the company employed 671 captains, 840 first officers and 89 flight engineers making a total of 1,600.

### **1.17.3 Company safety programmes**

In April 1998 consultants from the Flight Safety Foundation, at the request of Korean Air, carried out an Internal Evaluation Programme of the company. It determined that the safety programmes in place at the time were not designed to support the safety of the operations structure. Specifically it found weak points and deficiencies in the captain promotion system; the training curriculum; the integration of foreign crew members; the remedy for pilot induced incidents and operations standardisation.

From May 1998 to October 1999, as a result of this consultation, the company, entered into a consulting implementation project with a major US CFR Part 121 air carrier. This project looked at flight operations, in-flight service, flight operations control and corporate safety.

The project recommended the following changes:

#### **1 Flight Operations**

- (a) Reorganisation of flight operations into short haul and long haul fleets and crews.

- (b) A crew advancement system.
  - (c) A training programme focusing on instructor quality and standardisation; joint CRM training with flight deck and cabin crews; a fifth generation CRM programme including error management (ERM) training and training in the English language.
  - (d) Standardisation of the Flight Operations manuals (FOM); Pilot's Operations manuals (POM) and Line Check Pilot's manuals (LCPM).
- 2 Flight Operations Control
- (a) FAA approved flight dispatcher training.
  - (b) The introduction of a domestic VHF company radio network.
  - (c) The introduction of a flight watch / plan system.
- 3 In-flight services
- (a) Development of a cabin safety manual.
  - (b) Provision of training equipment and facilities.
- 4 Corporate Safety
- (a) The re-organisation of the safety structure.
  - (b) Training the specific areas of emergency response and internal evaluation.

The effect of the consultation was reported to have resulted in the company's motivation for safety improvement; the clarification of objectives for safety programmes as well as company business; internationalisation of standards, procedures and operating systems and the establishment of guidelines for the future.

Furthermore the company put into early retirement two of the older Boeing B747-200Fs (freighters) and two Airbus A300Fs (freighters). It opened an internet based 'crew link system' for improved two-way communication.

#### **1.17.4 Flying training**

Korean Air recruits and trains both ab-initio students and military - experienced pilots as first officers. Since 1989, Korean Air has had a dedicated flying school established on Cheju Island to the south of the Korean peninsula. The flying school operates a fleet of PA-34 (Piper Seneca 111) and Cessna Citation Ultra-V aircraft.

The basic and intermediate parts of the flight training are carried out at the Sierra Academy of Aeronautics at Livermore, California, USA. The pilots return from there with more than 250 hours of flight time, together with a Commercial Pilot's Licence and an Instrument Rating. At Cheju Island, they complete their advanced training of approximately 40 hours flight time. The instructors for the advanced training are volunteers from experienced Korean Air crews.

Flight Safety Boeing Training International (FSBTI) was contracted in June 1999 to carry out simulator training and checks through outsourcing. Korean Air pilots continue to carry out all line flying training and checks.

#### **1.17.5 Crew resource management (CRM) training**

Crew Resource Management (CRM) training within Korean Air consists of four elements; Initial CRM training; Recurrent training; a joint CRM training programme and Line Orientated Flight Training (LOFT).

The programme of initial CRM training, consisting of 28 hours of participation by newly appointed first officers, was first introduced in 1986. The programme was obtained from United Airlines (UAL) and Scientific Method Company and was used to train all 1,710 flight crew members of Korean Air.

In September 1998 a human factors team was established and in August 1999 an Error Management Course (EMC) task force team was established to develop and enhance the CRM course to reflect the Korean culture and assist in error management issues.

The Error Management CRM course, which was developed in 2000, meets or surpasses FAA and MOCT mandated guidelines, and is designed amongst other things to: improve flight safety and efficiency; to be tailored to suit the Korean culture; to include threat and error management and to study case histories of Korean Air accidents and incidents. Moreover, and fundamentally, the course is designed to be modified and improved in accordance with CRM evolution and industry developments.

A programme to enhance flight safety for flight crew and cabin crew has been in place since July 1999.

A LOFT programme, focused on decision making skills, was introduced in 1999 after an in-depth analysis of accidents and incidents and additional recommendations made by the consulting team. The theme for the year 2000 was planned to shift its emphasis to situational awareness.

In May 1999, a survey of KAL flight crews was conducted by the University of Texas Department of Psychology, through the consulting project. Over 550 pilots and flight engineers participated, in what was called the Flight Management Attitudes Questionnaire (FMAQ), responding to questions regarding 'Command Structure'. They were asked to detail their level of agreement to the following statements:

1. Juniors should not question the captain unless there is a threat to safety.
2. First Officers should never assume command of the aircraft.
3. Captains should take control/fly in emergencies.

Responses regarding these statements were then combined to form a composite score, from which was measured the differences in attitudes toward command. These were then compared to the results from sixteen other national airlines in which identical surveys had been conducted. The results showed, among other things, that KAL flight crews as a whole preferred the 'captain-centered' methodology of flight deck operation, with a relatively greater reliance on the captain.

In a follow-up survey conducted in 2002, an observable change had been reflected in the crews' response.

### **1.17.6 KAL maintenance organisation**

Korean Air have three major facilities in Korea dedicated to maintaining its fleet of aircraft. The largest (in terms of personnel employed) is situated at Kimpo International Airport, Seoul where Line and Base maintenance is performed together with some minor component repair. The next largest facility is at Kimhae (Pusan) in the south-east of the country where heavy maintenance and component repair and overhaul are performed. The third centre, dealing with powerplant heavy maintenance and testing, is at Bucheon.

Repair and overhaul of avionic components such as ADI's and INU's are carried-out completely in-house at Kimhae. Inspection of the avionic workshops by the AAIB indicated a well-equipped and organised facility, manned by personnel with good technical knowledge using the manufacturer's documentation.

A similar inspection of the relevant facilities at Kimpo also revealed a well-organised, modern and technically competent organisation. In particular, it was noted that KAL operated a 24-hour Maintenance Control centre, staffed by specialist engineers to handle queries from outstations and with access to all manufacturer's manuals. Informal inquiries with KAL personnel suggested that, when approached, the centre was competent, helpful and easy to contact. This centre also dealt with aircraft faults reported using the Aircraft Communication Addressing and Reporting System (ACARS). HL-7451 was not equipped with this system.

### **1.17.7 Korean Air aircraft handling arrangements at Stansted**

Although there are some variations, there are essentially three methods by which an airline can approach the problem of scheduled and unscheduled maintenance on its aircraft away from the airline's main base.

The first is to deploy its own full-time engineers at the outstation. This is clearly a relatively expensive option which may only be cost-effective if the number of services to that destination is high.

The second approach is to delegate the entire task to another operator or third-party maintenance organisation locally-based at the destination. This is known as 'Full Technical Handling' (FTH). Under such a contract, the service provider not only provides all the labour necessary to complete the task, including defect rectification, but also makes entries in the Technical Log Book. Such entries do not constitute responsibility for the airworthiness of the aircraft as a whole but do form a Certificate of Release to Service for the work done. It is normal for the State of Registry of the aircraft to signify some form of approval of the handling company, often by physical audit, where the personnel working on the aircraft do not hold licences valid for the State of Registry.

The third approach is to enter into a 'Technical Assistance' (TA) contract with the handling company. Typically the contract will specify a number of personnel and man-hours to perform the required routine checks and defect rectification. Implicit in such an agreement is the presence of a licensed representative of the operator who is the only person authorised to make entries in the Technical Log and hence certify the Release to Service.

KAL had a policy of only entering into FTH agreements with airlines experienced in operating the appropriate type of aircraft. They were in such an agreement with British Airways (BA) at Heathrow, although until relatively recently the contract had been on a TA basis, with a resident KAL station engineer carrying-out the duties of the representative described above. Neither contract with BA covered handling of aircraft destined for Stansted but did provide for KAL aircraft diverted there from Heathrow.

Technical handling of the solitary weekly scheduled freighter operation into Stansted was provided by FLS Aerospace (UK) Ltd, working under a TA contract with KAL. The contract itself was based on a Standard Ground Handling Agreement (SGHA) document devised by the International Airline



Transport Association (IATA). The scope of the responsibility for the various activities involved are laid-out in the SGHA Section 9 'Aircraft Maintenance' (see Appendix N, Figure 1). This section breaks all the various activities into numbered paragraphs, the applicable ones being specified in the main body of the contract. The main paragraphs of relevance to the investigation for which FLS had contracted responsibility were:

- (a) 9.1 'Routine Maintenance' (with the exception of 9.1.2 and 9.1.3)
- (b) 9.2 'Non-routine Services' (with the exception of 9.2.2 and 9.2.6)

It can be seen that most of the exceptions concern making entries in the technical documentation. Although the agreement does not mention precisely who would therefore make such required entries, it is implicit that this would be a task for an appropriately licensed KAL engineer. There was no resident KAL engineer at Stansted, and it had become the practice to dispatch a suitable person from other KAL outstations who did have such authority, to attend the turnaround of the Stansted freighter service. The FLS personnel who had worked on KAL aircraft in the few weeks that the service had been operating, said they had no knowledge of where the KAL engineers had come from, but there was always one present to meet the aircraft on its arrival.

A further attachment to the SGHA is shown in Appendix N, Figure 2 headed 'Paragraph 6 - Interface Procedures', it can be seen from sub-paragraph 6.1 that FLS were contracted to supply two mechanics, 'one of whom at least should have FAA, A&P or JAR 145 B747 License'. Sub-paragraph 6.8 refers to the KAL representative as 'The KAL Maintenance Manager'. The contract seems to assert that FLS were complying with sub-paragraph 6.1 by using their JAR 145 approval number CAA 00611. The FLS licensed engineer who first attended HL-7451 at Stansted did not hold any FAA licences.

### **1.17.8 Qualifications and training of the ground engineers**

KCAB basically uses the FAA system of trade nomenclature. Thus in the following description, 'A' refers to airframe and 'P' refers to powerplant. 'G' refers to avionics/electrics when discussing Korean personnel. In the UK, 'A' is used to denote Airframe, 'C' engines, 'X' for electrics, instruments, autopilot etc and R for radio/radar/navigation. The AAIB were advised that the Korean licence of 'maintenance engineer' together with an aircraft type rating, implied that that the holder could perform work in all three categories on that type. When asked if they could furnish a document explaining what such privileges allowed or did not allow, KCAB were unable to do so, but said that a separate 'avionics' licence would only be appropriate for someone certifying work in an avionics workshop.

#### **1.17.8.1 KAL engineer**

The ground engineer who perished on the accident flight started his career with KAL by undertaking a Basic Maintenance Course - AP&G in August 1978 and in April 1979 he undertook a B747-200 AP&G course. The former provided 100 hours of training and the latter 187 hours. Although he later attended type-related courses on the B747-300 and -400 variants and other aircraft, there were no further courses specifically on the B747-200. KAL were asked if they could provide a breakdown of the B747-200 type course in an attempt to gain some sort of impression of the amount of time that might have been devoted to the topic of ADI/INU interface. The breakdown provided unfortunately did not follow the ATA chapter format, but it would appear that such a topic would have been covered in the 'Navigation' section of the course for which a total of 14 hours had been allocated.

The KAL ground engineer was issued with his Maintenance Engineer's Licence in November 1980 and his Boeing 747-200 type rating in March 1981. He also held type ratings on the A300 and B747-400 aircraft. It was noted that, in April 1998, he had undertaken a course entitled 'Station Tech. Special Training'. From this it is inferred that he had only been operating as a station engineer for a relatively short time.

### **1.17.8.2 Local Stansted based engineers**

Although the 'Interface Procedures' document referred-to above specifies that two mechanics were expected to be allocated to the task of attending the aircraft, it appears that only one person was provided initially. This person (Engineer 'A') possessed a CAA Licence Without Type Rating (LWTR) in the A&C categories. As is now customary in the UK, to sign for a Certificate of Release to Service (CRS) he had to possess a Company Inspection Authorisation on types for which he expected to certify. Thus he possessed FLS authorisation on Boeing 747 - 100/200/300 and SP series airframe and airframe systems and CF6-50 and JT-9D engine installations on the same type. He did not hold any form of 'Avionics Extension' and was employed as a Licensed Technician.

The second FLS Engineer to attend the aircraft (Engineer 'B') was employed as an Inspector/Supervisor. He held CAA 'Multi-X' and 'R' LWTR's and full Company Authorisation in these categories on many different aircraft types including the B747-100/200 and 400 series.

### **1.17.9 Safety Inspections by foreign authorities**

#### **1.17.9.1 United States Department of Defence (DoD)**

United States military personnel are regular passengers on aircraft operated by Korean Air. In April 1999, as a result of its previous safety record, the DoD issued a temporary 'None-use status' on the company. This was followed, in May 1999, by a Civil Aviation Review Board (CARB) special hearing conducted in the US and, in October 1999, the carrying out of a 'special audit' by the DoD. By November 1999 KAL was re-instated into the DoD programme, however, on 22 December 1999 (the day of the accident) the DoD re-issued KAL with temporary 'None-use status'. This was followed by a further CARB hearing in the US in February 2000 where the DoD expressed an interest in aircraft inspection; overseas stations aircraft release and flight training progress.

### **1.17.9.2 Transport Canada**

Transport Canada carried out a 'Base' inspection of KAL during the period 26 January 2000 to 3 February 2000. The Canadian team visited the Korean Civil Aviation Bureau (KCAB) and carried out cockpit observations. The main focus of their visit was on flight operations; support; pilot recruitment; training; qualification; proficiency and upgrading. With regard to maintenance, the team examined quality assurance and maintenance control procedures and methods. Cabin crew manuals and training were also examined along with accident and incident prevention and the flight operational quality assurance (FOQA) programmes.

### **1.17.10 Follow-up safety action**

#### **1.17.10.1 KCAB actions**

As a result of the accident the KCAB focussed on reinforcing the oversight of the operator's overseas station maintenance. The number of airports where the operator deployed full-time engineers was increased from 31 to 43. The number of stations contracted for full technical handling was to be increased from 8 to 12. The number of destinations where the operator had previously dispatched non-resident engineers from other stations was reduced from 24 to 8. The licensed representative of the operator was to be given authority for a 'line-stop' decision and the minimum required turn-around time for international flights was to be increased from 40 minutes to one hour. A communications network to facilitate decision support from the operator's Seoul base was also reinforced.

Subsequent actions focused on regulatory reforms to harmonise with the advanced regulations of the Federal Aviation Regulations (FARs); safety information sharing by the adoption of a Korea Confidential Aviation Incident Reporting System (KAIRS); increasing the number of qualified and experienced aviation safety inspectors.

#### **1.17.10.2 Airline Pilot's Association**

In December 1998, the Airline Pilots Association of Korea (ALPA-K) was formed, representing the membership from 2,000 airline pilots of Korean Air and Asiana Airlines. In August 1999, the Korean Air Flight Crew Union (KAL FCU) was formed as a bargaining unit on KAL property to represent the interests of its 1,400 pilots and flight engineers, and was subsequently certified in May 2000 as a labour union by the Korean Ministry of Labour. In October 2000, the union signed its first collective bargaining agreement with KAL management, and secured numerous contract provisions deemed relevant to flight safety, including an annual flight time limitation of 1,000 hours, and a promotion system based on seniority date of hire, with restrictions for minimum flight time experience.

#### **1.17.10.3 KAL initial actions**

As a result of the accident the company Vice President of Safety and Security issued a Safety Directive (Safety and Security Directive No 9103-00C001) to all pilots on 14 February 2000. It stated that although the investigation was still in progress and regardless of the cause of the accident the following points needed to be emphasised. The text of the directive is reproduced below:

- 1 Thorough preparations for the complex malfunction of instruments during the critical phases.
  - (1) Anticipate any kind of failure at any time during the flight.
  - (2) Develop prompt cognitive ability and better decision making in abnormal conditions.
2. Keep it in mind with the basic principle 'Fly the Airplane' under any condition (especially under a high workload situation).
  - (1) During any abnormal situation, pilot will maintain aircraft control first.

- (2) Utilise secondary (Back-up) systems, selection of functional equipment, and its usage.
  - (3) Good crew communication, CRM is essential in decision making process, especially in abnormal conditions.
  - (4) All crew should not simultaneously become involved with the same area during high workload conditions.
3. Fully utilise PNF and flight engineer's monitoring function during the critical phases.
    - (1) To prioritise essential element before any duties, share more efforts on instrument interpretation and proper indication.
    - (2) During T/O and landing briefing, include emphasis on monitoring and plan the expected malfunctions or multiple malfunctions.
  4. Follow autopilot procedures having thorough knowledge of its performance and operation limitations.

#### **1.17.10.3.1 KAL subsequent safety initiatives**

Korean Air continued to develop Air Safety Initiatives after the Stansted accident and by April 2002 had brought about changes in the following areas:

##### *Flight operations selection*

The progression and upgrade system from the short haul to long haul fleet has been simplified and stricter requirements for promotion from first officer to captain (>4,000 hours, 350+ landings and 5 years+ as first officer) have been introduced.

##### *Flight crew training and checking*

'Special instrument failure' training was conducted during the first recurrent training undertaken by pilots in 2000 and has now been included in every first half yearly recurrent training session. Furthermore, during the first half of 2002, one additional simulator session had been programmed so that pilots could receive training in 'automation degradation'. Specific training was also introduced to train pilots in 'unusual attitude recovery techniques', the transferring of control when instrument failures occur and CRM issues. The KAL Human Factors Team was reinforced to develop a variety of CRM programmes including Joint CRM (JCRM) training with cabin crew and 'Error Management' training.

##### *Organisation and management*

Improved standardisation of flight operations has been achieved by the separation of training from line checking. Pilot training, Line Checking (Standardisation) and Line Operations are now conducted by separate independent departments. The selection of 'Line Check Pilots' (LCP) has also been improved with the emphasis focused more on ability than accumulated flight hours.

Company documentation has also been rationalised into four manuals: Flight Operations Manuals (FOM) I, II and III covering all aspects of flight operations; Pilot Operation Manual (POM) a specialised pilot guide for each aircraft type; Operation Data Manual (ODM) a reference manual concerning aircraft performance and a Flight Instructor's Guide specific to each aircraft type.

KAL's aircraft fleet has also been modernised and since 2000 twelve of the older aircraft have been sold and seventeen new aircraft have been introduced into service.

##### *Flight Quality Assurance*

KAL launched a Flight Quality Assurance department in 2000 consisting of 14 auditors. They perform audits of Flight Operations; monitoring compliance to regulations, standards and procedures to ensure safe operational practice and publications; continually evaluating their adequacy. The audits

are conducted periodically (annually for Flight Operations, LCPs, FSTBI instructors and ground school instructors), randomly (for individuals) and specifically (when corrective action from other audits are required).

#### *Maintenance and engineering*

Since the accident 28 more resident technicians have been dispatched to overseas stations. The 'on-board technician' system has been reduced from 15 out stations to one (Cairo, Egypt). Fault Isolation Manuals (FIMs) are now carried on board each aircraft so that 'mechanics' can have quick access when faults are reported and communications have been improved between outstations and headquarters. Aircraft technical documentation has also been revised so that copies of maintenance log pages can now be left with the maintenance manager at the point of departure.

Special inspections of all B747F aircraft were carried out in January 2000 a month after the accident. Items inspected included the ADI/INS system. Plans are in place, in order to satisfy the Future Air Navigation System (FANS) requirements, to upgrade aircraft equipment such as GPS, FMS, ACARS etc in the B747 classic fleet and by 2003 KAL plan to replace aircraft fitted with the LTN-72R INUs. Furthermore by the end of 2004 KAL expect to have Enhanced Ground Proximity Warning Systems (EGPWS) installed in all of its aircraft fleets.

Both initial and recurrent maintenance training (including English language improvement training) of KAL personnel, has also been improved along with a reinforcement of training for maintenance representatives contracted from other agencies.

### **1.17.11 Korean aviation statistics**

At the time of the accident, the Republic of Korea had two commercial flag airlines operating 158 aircraft of varying types. In addition there were 57 aircraft (including helicopters) operating in the commuter and non-schedule area of the market and 44 general aviation aircraft. Korean Air were operating a total of 108 aircraft of which 29 were Boeing 747-400 and 11 (post accident) were 747-200F (Freighters). Passenger transportation in Korea in 1999 was at a level of 16.6 million passenger movements a year having risen from 2.9 million in 1980 and 9.6 million in 1990. Likewise the transportation of cargo has risen from 191,000 tons in 1980 to 777,000 tons in 1990 and 1,631,000 tons in 1999.

### **1.17.12 Previous related accidents**

#### **1.17.12.1 Air India B747 accident**

On 1 January 1978 an Air India (flight AI855) B747-237B aircraft, registration VT-EBD, with 213 persons on board, departed Mumbai (Bombay) - Santa Cruz Airport, India for a scheduled passenger flight to Dubai. The aircraft was cleared to climb to 8,000 feet and report passing 2,400 feet. Following a right turn, the aircraft rolled to the left beyond 90° of bank and crashed into the sea 3 km from the shore. The probable cause of the accident was determined to be due to an Attitude Director Indicator (ADI) malfunction during the right turn leading to a loss of situational awareness by the crew.

#### **1.17.12.2 Korean Airlines B747 accident**

On 6 August 1997, at 0142 hrs (Guam local time), Korean Air (KAL) 801 crashed at Nimitz Hill, Guam. The aircraft, a Boeing 747-3B5B registration HL-7468 (KAL 801) had flown from Gimpo Airport, Seoul, Korea with 17 crew and 237 passengers on board. The aircraft had been cleared to land on Runway 06 Left at A.B. Won Guam International Airport, Agana, Guam and had crashed into high terrain about 3 nm southwest of the airport. Of the 254 persons on board, 228 were killed and 23 passengers and 3 flight attendants survived the impact with serious injuries. The aircraft was destroyed by impact forces and a post-crash fire. The flight was operating within U.S. airspace as a

scheduled international passenger service flight under the Convention on International Civil Aviation and the provisions of 14 Code of Federal Regulations part 129 and was on an IFR flight plan.

In the US National Transportation Safety Board (NTSB) accident report (NTSB/AAR-00/01) it was determined that the probable cause of the accident was the commander's failure to adequately brief and execute the non-precision approach and the first officer's and flight engineer's failure to adequately monitor and cross-check the commander's execution of the approach. Contributing to these failures were the commander's fatigue and Korean Air's inadequate flight crew training. An additional contributing factor was the Federal Aviation Administration's intentional inhibition of the minimum safe warning (MSAW) system at Guam and failure to adequately manage the system.

Recommendations were made to the Federal Aviation Administration, to the Governor of the Territory of Guam and to the Korean Civil Aviation Bureau.

## 1.18 Additional information

### 1.18.1 Applicable KAL flight procedures

#### 1.18.1.1 Flight Director Indicator Attitude display failure procedure

The Korean Air, Boeing 747 Operations Manual (dated May 01/86) under NAVIGATION ALTERNATE OPERATIONS contained the following drill:

#### **NAVIGATION SYSTEM MALFUNCTION INDICATIONS**

#### **BOTH CENTRAL INSTRUMENT WARN LIGHTS FLASHING**

#### **IF BOTH ATT LIGHTS ILLUMINATED:**

Both WARN Lights . . . PRESS TO EXTINGUISH

Standby Attitude Indicator (and other instruments) . . . CROSS CHECK AGAINST ADI'S

*[In Korean language]* GYRO Flag may or may not appear if the ADI is malfunctioning.

ATT/COMP STAB Switch . . . TRANSFER APPROPRIATE PILOT TO ALT

*[In Korean language]* Observe ATT Lights extinguished ("OFF")

#### **IF BOTH HDG LIGHTS ILLUMINATED:**

Both WARN Lights . . . PRESS TO EXTINGUISH . . .

#### **ONE CENTRAL INSTRUMENT WARN LIGHT FLASHING**

ADI and HSI on Side with Flashing WARN Light . . . CHECK FOR FLAGS

### 1.18.1.2 Initial actions and recall action

The Korean Air B-747 Operations Manual (dated June 01/99), under EMERGENCY ABNORMAL PROCEDURES, INTRODUCTION contained the following flight crew instructions pertaining to Initial Actions and Recall Action:

#### *Initial Actions*

*[In Korean language]* The crew member who discovers an emergency/abnormal situation requiring immediate action must immediately report it to the captain.

#### *Recall Action*

*[In Korean language]* The captain takes emergency actions as necessary to continue flight, and directs the use of appropriate Checklist. Accordingly, the designated crew member immediately executes the Checklist BOXED items.

(It is noted that the Flight Director Indicator Attitude Display Failure Procedure was not found under the Emergency Abnormal Procedures.)

### 1.18.1.3 Boeing 747 ground school guide

The Korean Air B-747 Ground School Guide, which was distributed to flight crews during training, provided aircraft systems information in the Korean language, consistent with the Operations Manual. Under Section 14, titled Navigation, there were nine practice problems, with correct answers provided as follows:

#### **Practice Problem** *[In Korean language]*

2. In the event of a "GYRO" FLAG appearing on the captain's ADI:

When the **ATTITUDE/COMP STAB SW** is placed in "ALT" position, the signal source will **TRANSFER** from the **No.1 INS ATTITUDE REFERENCE** to the **No.3 INS ATTITUDE REFERENCE....**

8. If the "INST WARN" LIGHT and the "ATT" LIGHT are illuminated on both PANELS?

The response is:

**PRESS to extinguish the LIGHT**

**CROSSCHECK against the STANDBY HORIZON or other ADI to determine which indication is incorrect.**

**Place the applicable ATTITUDE/COMPASS STAB in "ALT" position and MONITOR the ADI.**



## 2 Analysis

### 2.1 Introduction

The crew that operated HL-7451 on the sector from Tashkent to Stansted experienced a problem with the altitude indication on the captain's ADI, a primary flight instrument. Entering a right turn at 1,000 feet agl on the departure with the commander handling, the ADI comparator warning was triggered. This illuminated the flashing red INST WARN light and the steady amber ATT light, mounted immediately above each ADI, with an aural warning from two horns, one mounted each side of the flight deck. The fault, the captain's ADI failing to indicate correctly the aircraft's bank angle, was correctly identified by the commander and the appropriate action taken to retain full control of the aircraft. Control was handed over to the first officer who flew the remainder of the turn and continued with the climb.

The time of day and weather conditions were conducive to the crew achieving a successful outcome in that a clear external horizon was visible, with the sun low above the horizon, to assist them in responding to the fault and retaining control of the aircraft. There was later some conflict between what the commander remembered as the roll indication compared to the information obtained from the FDR but the important fact was that the fault was detected, and contained. Thereafter, the crew carried out some in-flight trouble shooting, the commander selecting 'ALT' on his 'Attitude and Compass stabilization selector switch', switching from INU No 1 to INU No 3 for his ADI data source. Within an estimated five seconds his ADI displayed the correct roll indication and all the warnings disappeared. Post-flight, the flight engineer entered the defect in the Technical Log using the Fault Reporting Manual. Additionally, he briefed the KAL ground engineer at Stansted, in the Korean language, about the fault and about the important fact that the instrument worked with INU No 3 selected. Therefore, the fault was correctly reported and amplified with a verbal handover to the ground engineer responsible for clearing the Technical Log. However, the rectification action employed did not clear the fault and, on the subsequent departure from Stansted, the outbound crew lost control of the aircraft.

As with many accidents, the end result was dependent on many factors. This analysis considers certain factors which may have had a bearing on the outcome and/or which could have prevented the accident. These include the following:

- (1) The flight instrument system
- (2) Fault reporting
- (3) Fault diagnosis
- (4) Rectification action and recording.
- (5) Engineer licensing issues
- (6) Crew anticipation of a recurrence of the fault
- (7) Pre-departure crew distractions
- (8) Crew actions after takeoff.

## 2.2 The flight instrument system

Maintenance records indicate that the captain's ADI was fitted some five months prior to the accident, at which time it is likely that the No 2 socket on the J1 connector became displaced. The lack of any attitude instrument malfunctions or comparator warnings over this period, with the exception of the roll attitude warnings on both the accident and preceding flights, indicates that pin and socket No 2 in connector J1 were in contact. Therefore, the displaced socket was not associated with the failure of the captain's ADI to indicate the correct roll attitude of the aircraft after takeoff from Tashkent.

The selection of 'ALT' on the captain's altitude and compass stabilisation selection switch cancelled the comparator trigger for the warning systems and resulted in the captain's ADI indicating correctly. As this selection changed the attitude data source for the captain's ADI from INU No 1 to INU No 3 it confirmed that the fault was not with the ADI or its connections but was a fault with data supplied by INU No 1.

The standard of INU fitted to the aircraft (LTN-72) was such that the pre-flight operation of the BITE systems would not have detected the type of fault present in INU No 1 before either of the two final sectors. In addition, none of the fault monitoring circuits would have detected the fault until the aircraft manoeuvred beyond 4° of bank angle. Therefore, the crews on both flights were confronted with comparator warnings as they entered the first turning manoeuvre after takeoff. Significantly, on the accident flight, the crew were confronted with the challenge of interpreting the warning, when the handling pilot's primary attitude instrument failed to respond to aircraft bank angle, as the aircraft entered cloud at low level, at night, and in an area with virtually no cultural lighting.

Some operators have replaced the LTN-72 INUs with more reliable LTN-92 INUs, the MTBUR increasing by a factor of four. However, this improvement is achieved by replacing the mechanical gyroscope system with a laser gyroscope system, which would not have precluded the existence of the dormant fault experienced on HL-7451.

The type of ADIs fitted to the aircraft (Rockwell Collins Part No 772-5-5-001) present pitch altitude by the movement of a roller blind between horizontal top and bottom rollers. To create a circular presentation a fixed blue segment mounted above the top roller and fixed black segment mounted below the bottom roller complete the picture. If indicating correctly, when the aircraft is pitched nose down from a level attitude the area of blue diminishes and the area of black displayed increases. When the aircraft is pitched 15° nose down, the horizon is positioned along the bottom, flat edge of the blue segment. (Appendix O, Figure 1.) Further nose down pitch changes do not result in changes of the areas of blue and black displayed but are indicated by pitch reference lines marked in white on the black blind. (Appendix O, Figure 2.)

However, in normal operations of wide bodied jet aircraft nose down attitudes are usually no more than 5° and an attitude approaching 15° degrees nose down would be extreme and calling for pilot intervention. Therefore, the presence of the fixed blue segment on the ADI is not considered to have contributed to the loss of control. The attitude presentations at impact for the captain's and the first officer's ADIs are shown at Appendix P.

### 2.2.1 INU interaction with other aircraft systems

The FDR data together with the crew evidence for the Tashkent to Stansted flight confirmed that INU No 1 roll outputs 1 and 3 were defective, leading to the conclusion that the remaining roll channels were probably similarly affected. Roll 3 signal additionally goes to the weather radar; thus the effectively zero roll angle sensed by the system would have resulted in a failure of the radar dish to tilt in order to compensate for aircraft bank angles. It is probable, that at low bank angles, this would not have been noticed by the crew.

The roll 2 signal is sent to the autothrottle and upper yaw damper. As far as the autothrottle is concerned, the system would have failed to apply power as the aircraft banked, which it would

normally do in order to compensate for the increase in drag. Again it is probable that this would not have been apparent to the crew at low bank angles. The upper yaw damper would also effectively be inoperative. However there would be little effect so long as the lower unit (supplied by INU No 2) was functional.

Autopilot/Flight Director 'A' roll computer receives INU No 1 roll 4 output and is the only system that receives the Auxiliary warning (ie INS 'valid') from the INU. The flight from Tashkent to Stansted was reportedly conducted with autopilot 'B' engaged. The commander stated that during the approach into Stansted, 'land' mode was selected prior to localiser capture, followed by engaging autopilots 'A' and 'C'. The aircraft turned to intercept the localiser without any problem and the autopilot was disconnected at about 1,200 feet and the aircraft landed manually. This posed the question of why autopilot 'A' did not drop out during the approach, as the output of autopilot/flight director 'A' roll computer would have differed from the others, due to the near-zero bank angles input to the unit. The autopilot manufacturer, Honeywell, indicated that at small attitude changes resulting in low bank angles, the difference may not have been large enough to trigger the detector system that monitors each channel. The principal factor that verifies system integrity is the INS 'valid' signal from INUs No 1, 2 and 3 supplying autopilots 'A', 'B' and 'C' with the affected channel disconnected in the event of the signal becoming invalid. All three INS 'valid' signals were maintained throughout the accident flight.

## 2.3 Fault reporting

The flight crew and KAL ground engineer died in the accident and no copy of the relevant Technical Log entry was left at Stansted. Therefore, there is no record of what the ground engineer entered into the Technical Log, to clear the aircraft for flight, or what verbal information, if any, was passed to the commander regarding the ADI fault and its rectification. Nevertheless, evidence from the inbound crew indicates that the fault was recorded in the Technical Log in accordance with the FRM. Furthermore, the flight engineer amplified this with a comprehensive verbal debrief to the ground engineer, including pointing out that the indicator worked normally when the captain's Attitude and Compass Stabilisation switch was selected to 'ALT'. Despite the accurate reporting of the fault in the Technical log supplemented by the briefing above, the aircraft departed Stansted carrying the same fault with which it had arrived.

## 2.4 Fault diagnosis

In the absence of the relevant Technical Log entries and with the KAL ground engineer receiving fatal injuries in the accident the only 'record' of the fault finding/rectification is that recalled by the two local engineers at Stansted.

The entering of the appropriate code from the FRM in the Technical Log meant that cross reference to the FIM during the defect investigation would have led to identification of the correct maintenance response, which was the replacement of the No 1 INU. Alternatively, the aircraft could have been despatched with the captain's ADI receiving attitude data from INU No 3 by selecting 'ALT' on his 'Attitude and Compass stabilization selector switch. The FIM for that particular model of aircraft was not, at the time of the accident, carried on the aircraft nor had KAL provided a copy of the FIM to FLS Aerospace. It is also unlikely that the KAL engineer brought the manuals with him.

If he was at all uncertain about the correct course of action, the KAL engineer could have contacted his maintenance control in Seoul or have sought the advice of FLS specialists at the troubleshooting stage. It is possible that, being unfamiliar with the UK engineer licensing system, he believed that Engineer 'A' held some form of avionic qualifications like himself and, by not disagreeing with it, was endorsing his course of action.

Engineer 'A' appears to have been aware of the crucial information, that the indications were 'OK in Alternate'. This fact should have alerted someone familiar with the system that replacement of No 1 INU was the correct response, but given his background and training, he was not aware of the significance.

Engineer 'B' was called upon to rectify the displaced socket No 2 of the J1 connector and so, although avionics trained, did not become involved in the defect identification from the Technical Log entry.

## 2.5 Rectification action and recording

Re-racking of avionic components and cleaning/re-making of connections are fairly common responses to pilot reports of avionic/instrument defects. In some cases this can resolve the problem but in others it may simply be an attempt to despatch the aircraft where the fault cannot be reproduced on the ground, either because the system itself only functions in the air or the fault itself is intermittent. In either case it is assumed that the outbound flight crew would be asked to 'report further' which would, at the very least, alert them to the possibility that the system or component may still be faulty. As he perished in the subsequent accident, it is impossible to be sure why the KAL engineer embarked on the course of action he did.

Having decided to remove and check the connections to the captain's ADI, the KAL engineer sought access to the necessary tools from Engineer 'A' but did not consult with him on the logic of this approach. Although not an avionics/instrument specialist, Engineer 'A' considered it appropriate to assist by removing the instrument, a straight forward mechanical task.

The subsequent discovery of a 'pushed-back pin' almost certainly misled the KAL engineer (and probably the flight crew) into thinking that he had discovered the cause of the defect and that, if rectified, the system would then function correctly. He sought further assistance from Engineer 'A', but not feeling competent to rectify the pushed-back pin, Engineer 'A' sought additional support from an avionics engineer, Engineer 'B'.

Engineer 'B' was qualified and experienced in the subject system and was capable of correctly diagnosing the defect had he been involved at the troubleshooting stage. However, he only became involved at his colleague's specific request to reset the socket. When questioned about his knowledge of the exact nature of the defect and what he would have done had he been asked to troubleshoot, he replied that he would have consulted the FIM, which would have led to the correct identification of the rectification action. However, when he attended the aircraft, he was presented with a specific request and he, like Engineer 'A', believed that the KAL engineer had conducted the troubleshooting procedure - the task he was actually asked to perform was minor and routine.

It could be argued that, having reset the socket, he should have had no further involvement in the task. However, he continued to connect, disconnect, check and reconnect the plugs of the captain's ADI and then refit it and conduct the functional test, which he had not been asked to do. In so doing he was demonstrating a spirit of co-operation and helpfulness which is often seen in the aviation industry, particularly when turning-round an aircraft on the line. However, he was now completing a process, which he had not started (a commonplace factor in maintenance errors) but the KAL engineer seemed content for this to continue, perhaps reassured that an apparently knowledgeable and qualified engineer was checking and, by implication, endorsing his approach. In particular, the ADI self-test, requiring as it does the initialisation of the INUs to give a start and finish attitude reference only, might have appeared to the KAL engineer to be a test of the complete attitude reference/indication system. Significantly, this was also witnessed by the first officer who may also similarly not have understood the limitations of the tests inasmuch as it only tests the function of the instrument itself and not the data source.

Analysis of the wiring diagrams after the accident showed clearly that, not only was the pin (socket) not relevant to the reported defect, but it must still have been making contact even if it was somewhat displaced in the connector.

No record of the maintenance or routine elements of the turnaround were left at Stansted. The Technical Log and the Transit check list were carried on the aircraft and no copies of these documents were left with the handling agents. Under UK regulations and ICAO Standards a copy of the Technical Log would be required to be left on the ground.

Throughout the defect investigation and attempted rectification, language difficulties resulted in limited dialogue and the potential for confusion over the respective responsibilities of the engineers

involved. However, on any occasion when responsibility for and conduct of maintenance activity is shared by more than one organisation, particularly in the time critical environment of line maintenance, the potential for misunderstanding exists. This situation is best avoided by the operator deploying sufficient of its own full-time engineers at the outstation or by delegating the entire task to another operator or third-party maintenance organisation locally-based at the destination (Full Technical Handling). If neither of these approaches is practicable then the support arrangements must be detailed and of such clarity as to preclude confusion.

It is recommended that:

Korean Air continue to review its policy and procedures for maintenance support at international destinations with a view to deploying sufficient of its own full-time engineers at the outstation or delegating the entire task to another operator or third-party maintenance organisation locally-based at the destination (Full Technical Handling). If neither of these approaches is practicable then the support arrangements must be detailed and of such clarity as to preclude confusion.

[Safety Recommendation No 2003-63]

The investigation of the maintenance input at Stansted during the aircraft turnaround was hampered by a lack of documentation

It is recommended that:

Korean Air review its policy and procedures to ensure that a copy of the relevant pages of the Technical Log and any other transit certification documents are left on the ground at the point of departure.

[Safety Recommendation No 2003-64]

## 2.6 Engineer licensing issues

Although no documentation was presented covering the privileges (and limitations) of a Korean A, P and G engineer licence, it appears that holders can perform and certify virtually any line maintenance work on aircraft for which they have type approval. The training undertaken to gain such approvals covers the whole aircraft and its systems in all their diversity.

In the UK, licensed engineers with such wide-ranging authority are relatively rare. Since most scheduled line maintenance activities are predominantly airframe and powerplant-based, line maintenance engineers tend to be A&C licence holders. However, non-scheduled line maintenance (defect rectification), can clearly involve any number of avionic/electrical systems and for these an 'avionics extension' is granted. Involving about two weeks additional study in these systems, the holder may perform most of the routine tasks likely to be encountered as part of line defect rectification. This includes troubleshooting (where there is no doubt about the faulty component), Line Replaceable Unit (LRU) exchange, and any testing using on-aircraft equipment (eg Built-in Test Equipment, BITE). Testing involving external equipment or wiring/connector rectification would require the services of an engineer holding the appropriate 'X' or 'R' licences.

Discussions with a number of engineers holding A&C licences with avionics extensions suggested that, even with the latter qualification, most would have preferred to consult a colleague with avionics licences if presented with a Technical Log entry involving the ADI as described. However, it must be recognised that those involved worked for a large airline at the company's main base, and had relatively easy access to such expertise. Away from such support, they would have used the troubleshooting manuals or contacted their maintenance control for guidance.

FLS Aerospace at Stansted was akin to the 'major airline at its home base' situation referred to above, with a large pool of qualified and experienced Boeing 747 engineers and comprehensive facilities appropriate even for the heaviest of maintenance tasks. However, the KAL engineer chose, or somehow felt obliged, to operate as though he had little or none of these assets to draw upon. This may have been the case at Moscow, his normal base, where it is understood Korean Air used a Russian airline on a TA basis when required. Whilst undoubtedly possessing skilled manpower and facilities, the airline would probably not be familiar with Western aircraft and he may have been used to making self-reliant technical decisions about his company's aircraft maintenance. If, as it appears, his training was roughly equivalent to a CAA A&C licence with avionics extension, in the UK he would not have been permitted to embark on a self-devised process of troubleshooting. The correct course of action would have been to consult the FIM using the code entered by the flight crew or to have contacted KAL maintenance control for guidance. By not doing so, he also denied himself the option of despatching the aircraft with the defective INU and the captain's ADI selected to the alternate source, which was permissible for the next sector under the Master Minimum Equipment List (MMEL).

It must be concluded that, in embarking on the course of action he did, he had insufficient technical knowledge of the ADI/INU interface. This is not surprising, given that his grounding in this topic was not intended to equip him with the knowledge to devise his own troubleshooting scheme, which proved in this case to be incorrect. With hindsight, given the pool of manpower and resources available at FLS Aerospace, it would appear unnecessary for them to have been contracted on a TA basis only, assuming that the company had, or could gain KCAB approval. Bearing in mind the CAA and JAR 145 approvals they held, this should have been a formality. Had a FTH agreement existed between KAL and FLS, there is little doubt that Engineer 'A' discovering the defect by seeing the entry in the Technical Log and preferably also through discussion with the inbound crew, would have contacted an avionics-qualified colleague (as he did with the connector problem) or FLS Maintenance Control for assistance with troubleshooting. Either of these were much better equipped to address the defect than the KAL engineer, assuming that FLS Aerospace would have insisted on being supplied with a FIM for that model of aircraft if contracted on an FTH basis.

## 2.7 Crew anticipation of a recurrence of the fault

Regardless of the rectification, the commander was probably aware of the defect, as reported on the previous flight and had an opportunity to question the ground engineer. Furthermore, one of the flight crew had been on the flight deck while the FLS engineer was refitting and testing the captain's ADI. If the commander, or any of the flight crew had doubts as to the serviceability of the ADI, there was sufficient time during start and taxi for a comment to be made. Nothing relevant to the ADI was recorded on the CVR. It is possible that something was said during the take-off brief (which was not recorded on the CVR) but, if the commander had any doubts on the serviceability of the ADI, it is reasonable to assume that the point would have been re-emphasised sometime prior to takeoff. The lack of any recorded comment indicated that none of the flight crew were concerned about the serviceability of the ADI.

Modern aircraft are generally reliable and any unserviceabilities are normally rectified during turnarounds. In this instance, it is reasonable to assume that the ground engineer considered that he had identified a fault and that it had been rectified. Therefore, the Technical Log would have indicated that the fault had been cleared. Additionally, there was a flight crew member in attendance on the flight deck while some of the rectification and 'Testing' of the ADI was being done and this would have generated confidence in the minds of the flight crew. On balance, it was reasonable for the commander to assume that the fault had been corrected and that the ADI was serviceable; the lack of any visible warning flags on the instrument prior to takeoff would also have confirmed this view.

If the commander had had any suspicions about the effectiveness of the rectification he had certain choices. Firstly, he could have remained on the ground. Secondly, he could have flown with his ADI sourced from INU No 3, as authorised by the Minimum Equipment List (MEL); this is unlikely because no comment was heard referring to this action. Thirdly, he could have given the duties of handling pilot to the first officer, thereby enhancing his capacity to closely monitor the aircraft attitude on the two ADIs. This did not happen because of the evidence of allocated duties heard on the CVR. It is also noteworthy that the company rules, at the time of the accident, precluded the first officer from taking the handling duties other than in an emergency because of his flying experience on type. A fourth, and perhaps the most sensible option, was for the commander to retain the handling duties but to require the first officer and flight engineer to specifically monitor his, (the captain's), ADI. If he had decided on this precaution, he would be expected to have reminded his fellow crew members of this additional duty just prior to takeoff. The lack of any such comment on the CVR is evidence that he assumed handling duties but with no specific instructions to his colleagues to monitor his ADI. It is surprising that the commander did not seem to consider the possibility of a recurrence of the fault with his ADI on departure. However, prior to flight, the crew were subjected to distractions (see paragraph 2.8 below), mostly outside their control, and the commander would have been understandably frustrated.



## 2.8 Pre-departure crew distractions

The flight crew had arrived at the aircraft with sufficient time to enable them to achieve their departure time. The first minor problem occurred when they could not contact 'Stansted Delivery' at 1727 hrs; however, within two minutes, they had made contact with ATC on 'Stansted Ground'. Unfortunately, ATC had no details for the flight and the crew were advised to contact their handling agents. The agents had not submitted the flight plan and it was not until 1742 hrs that ATC had received the flight plan and advised the crew of their clearance. The next distraction was a delay in providing a vehicle to push-back HL-7451 and clearance to push-back was not received until 1813 hrs. Then, during the push-back, it became apparent that the vehicle was having problems and it was necessary for a marshalling vehicle to position and for the aircraft to be marshalled onto the taxiway centreline. Clearance to taxi was given at 1825 hrs, some 58 minutes after the crew initially attempted to contact ATC. It is not unusual for crews to be subjected to some delays or distractions during clearance and ground movement at airports but the delay experienced by the crew of HL-7451 was greater than normal and would have resulted in an understandable degree of frustration in the commander. Content of the CVR indicated that the commander was showing signs of frustration. After personally handling the ATC communication a number of times prior to and during engine start (KAL standard procedure is for the first officer to handle ATC radio calls), he suddenly reprimanded the first officer for not responding to a radio call. On the taxi call, he faulted the first officer for not advising him to taxi to the centreline, then on receiving the line-up clearance told the first officer that a 'Roger' alone was sufficient. By making these comments, it is considered that the commander contributed to setting a tone which discouraged further input from the other crew members, especially the first officer.

Following clearance to taxi, the crew were subsequently cleared to takeoff at 1836 hrs, some 10 minutes later. However, in the intervening period, there was evidence on the CVR that the commander was unsure if the Stansted DME was working correctly as his instrument indications appeared unusual. Subsequent checks of the equipment indicate that it was working correctly but it may have been a configuration with which he was not totally familiar. Nevertheless, he was sufficiently concerned to ask his first officer to check his indications. The flight engineer then commented that the indications appeared correct. The commander appears not to have considered utilising the alternative method of using the Barkway VOR radial to define his SID turning point. This would have alleviated his concern for the intermittent DME indication. Unfortunately, his concern over the DME indications continued after takeoff and may also have had the effect of concentrating his attention on that indication and navigation to the detriment of monitoring attitude. His final request of the first officer, when the aircraft was descending with an extreme angle of bank and nose down pitch attitude, was to request radar vectors. The commander's apparent fixation on the DME-defined turning point, to the detriment of monitoring other flight indications, may have been a self-imposed pressure to strictly comply with the SID track to avoid a 'violation', in an area with an active noise monitoring programme.

## 2.9 Crew actions after takeoff from Stansted

### 2.9.1 Comparator warnings

The takeoff was normal until approximately 17 seconds after rotation when the comparator warning was triggered by a disturbance in the roll attitude as the aircraft climbed through 600 feet agl. There was no audible response from any member of the crew to this warning. The horns were probably automatically silenced as the aircraft rolled back towards wings level and both amber ATT lights should have extinguished. The red INST WARN lights would have continued to flash until individually cancelled.

Some eight seconds later, with the aircraft now at 1,200 feet agl, a similar event occurred again triggering the comparator warning and the horns sounded for a further one second. As before, there was no audible response from the crew and the commander continued to express concern about his DME and discussed the required SID heading following the imminent left turn.

Some five seconds later a left turn was initiated which again triggered the comparator warning, one horn sounding for four cycles the other for nine+ cycles before being cancelled by the pilots. The ATT amber lights would have remained illuminated but dimmed after the INST WARN light/horns had been cancelled until impact.

It is possible, if they were not cancelled earlier, that the red INST WARN lights continued to flash above the attitude instruments from the time of the first comparator warning until they were cancelled in the SID turn. Either way, the red INST WARN lights were either illuminated for up to 22 seconds or were cancelled more than once without any audible exchange between the pilots.

The flight engineer made three comments about the aircraft's bank attitude and one remark about the standby attitude indicator. The first remark, "BANK AHN-MEOG-NEH," meaning literally '*the bank is not accepting*', indicating his disbelief that the aircraft was not responding to the left roll input and substantiating that his initial attention was on the captain's malfunctioning ADI. Four seconds later he remarks "BANK, BANK", a comment possibly meaning that, in accordance with the standard callout procedure, he had recognised and was warning the commander of a bank angle greater than 30 degrees. At that time he could possibly have been looking at the first officer's ADI. The third remark, "STANDBY INDICATOR *ALSO NOT WORKING*" (italics denote translation from Korean language). (The third word could not conclusively be interpreted), demonstrates that he was alerting the commander to look to the standby attitude indicator in order to decide which ADI had failed. His last remark before impact also contained the word "bank," and appeared to be said with resignation for what was about to happen. At no time throughout the short flight did either of the pilots refer to the warnings or comment about the aircraft attitude or performance.

### 2.9.2 Commander's actions

The commander was the handling pilot for the departure. As stated above, the takeoff was normal until the first comparator warning. After the calls of "gear up" and "set IAS" the only audible comments from the commander concerned his DME readout and navigation of the SID. After initiation of the left turn the comparator warning activated and was cancelled. The derived position of the control wheel indicated that a left roll command was maintained until impact. During this time the captain's ADI indicated wings level but with an increasing nose down attitude. If in use, as it almost certainly was, the captain's Flight Director would, as the aircraft bank exceeded that commensurate with the departure turn and subsequently as the aircraft heading passed through the desired track of 158°, have demanded a roll to the right. As the aircraft began to pitch nose down the Flight Director would have been commanding a roll to the right and a pitch up. There is no evidence that the commander responded to the Flight Director or the aircraft nose down pitch attitude indication. Equally there is no evidence of him invoking the ADI failure drill by consulting the first

officer's and standby attitude instruments to determine which of the two primary attitude instruments was correct.

There is no evidence to explain the commander's lack of response to a number of significant cues. The aircraft was apparently failing to respond to a control wheel roll demand such that the roll command was maintained for an abnormal period with a pitch attitude displayed that he will have never experienced before in a large civilian aircraft. The comparator warning was activated a number of times and as the aircraft descended it was accelerating. This is particularly difficult to explain given the commander's total experience of 13,490 hours with 8,495 hours on the Boeing 747.

This experience, however, may also have worked against the commander in detecting the problem. Pilots are taught to believe their instruments. Through practical experience over a long period of time, the idea is reinforced in the mind of the pilot. It is probable that this commander had not experienced an ADI failure, despite his long flying career. When the ADI did fail, he was apparently not able to recognize the problem, because his primary frame of reference had always been through his visual interpretation of the ADI attitude display.

Under James Reason's error classification of rule-based mistakes, for any task, rules must be selected by the cognitive system, where several rules might compete for selection. 'The selection occurs according to which rule matches the given conditions best, supplies the highest degree of specificity, and can boast the greatest degree of strength. Rule strength is defined to be the number of times a rule has performed successfully in the past. Occasionally, rule strength might override the other factors, possibly resulting in the misapplication of 'good' rules. Reason calls this the application of 'strong-but-wrong' rules. For instance, it is highly likely that on the first occasion an individual encounters a significant exception to a general rule, the 'strong-but-now-wrong' rule will be applied.'

(Daniela K Busse and Chris Johnson, *Using a Cognitive Theoretical Framework to Support Accident Analysis, Proceedings of the 2<sup>nd</sup> Workshop on Human Error, Safety, and Systems Development*, Seattle, April 1998). Reason cited the abundance of information confronting the problem-solver in most real-life situations as the basis for rule-based mistakes, and that it almost invariably exceeds the cognitive system's ability to apprehend all the signs present in a situation, leading to cognitive information overload. Accordingly, the commander's loss of attitude orientation may be explained by his facing a *mismatch* between his aural perception of aural warnings/the flight engineer and his visual perception of the instrument indication. The commander instinctively maintained left roll input, because being deprived of his usual visual feedback through the ADI, he never recognized that it might be wrong.

Methods to overcome such situations have been devised, in the form of engineering solutions, effective training, and cockpit resource management techniques to improve situational awareness, manage workload, plan, co-ordinate, and communicate effectively. At the time of the accident, recovery from unusual attitudes or unreliable attitude information was not being practised during recurrent simulator training, where cognitive dissonance is intentionally introduced between the actual aircraft attitude and the instrument representation thereof, to reinforce good habit patterns for early recognition of the problem.

In the Korean Air B-747 Operations Manual, under EMERGENCY ABNORMAL PROCEDURES, there were a number of procedures which require immediate 'Recall Action', where 'the captain takes emergency actions as necessary to continue flight, and directs the use of appropriate Checklists. Then, the designated crew member immediately executes the Checklist BOXED items [from memory]'. The procedure for 'NAVIGATION SYSTEM MALFUNCTION INDICATIONS', where 'BOTH CENTRAL INSTRUMENT WARN LIGHTS FLASHING', 'IF BOTH ATT LIGHTS ILLUMINATED': appears on page 19.20.03 of the Operations Manual, NAVIGATION ALTERNATE OPERATIONS. While this alternate operations procedure prescribes an adequate course of action to be followed under circumstances which this crew faced, it does not specifically require immediate recall action from memory as under the emergency procedures.

It can be argued that at the time of the accident KAL crews, in general, were not adequately equipped to deal with this malfunction in a timely manner to avoid loss of control.

Incapacitation of the commander was considered as a possible explanation for a lack of response to the audio/visual warnings, calls from the flight engineer and divergent aircraft attitude. However, the movement of the control wheel and comments from the commander about navigation which continue up to a few seconds before impact indicate that he remained conscious and active.

### **2.9.3 First officer's actions**

The first officer was performing the duty of non-handling pilot, making all of the radio calls and responding to instruction from the commander. Following takeoff the first officer called "POSITIVE CLIMB" and, in response to the commander, 'gear up' and 'IAS' (Appendix H). He called "PASSING 900 FEET" which was followed by the first comparator warning and then confirmed the SID turn at one point five DME saying "YES SIR". The warning sounded a second time and he confirmed "ONE FIVE EIGHT" after a pause possibly checking the SID instructions. Just after the comparator warning started for the third and final time he received an ATC instruction to change radio frequency. He acknowledged the request "ONE ONE EIGHT TWO KOREAN AIR EIGHT FIVE ZERO NINE". It was to be expected that he would then have set about tuning a radio to the rear of the centre console. He cancelled the comparator warning but no further comments were heard from the first officer.

In addition to his radio duties and responses to the commander's instructions, as the pilot non-flying, he would have been expected to maintain a scan of the aircraft's flight instruments to monitor the aircraft departure performance and navigation. On detecting any attitude/performance or navigation anomaly he would have been expected to bring this to the handling pilot's attention.

At no time did the first officer respond audibly to the comparator or flight engineer's warnings or comment to the commander about the extreme aircraft attitude, which was developing. It remains a matter of conjecture as to whether he was so distracted by other duties that his instrument scan broke down, to the extent that he was unaware of the aircraft attitude and did not appreciate the significance of the comparator warnings, or he felt inhibited in bringing the situation to the attention of the commander. He was an inexperienced first officer with a total of 1,406 hours with just 73 hours on type and had been criticised a number of times by the commander prior to the takeoff.

### **2.9.4 Flight Engineer's actions**

The only airborne activity of the flight engineer identifiable from the recorded data was after the initiation of the left turn when the comparator warning sounded for the third time. He appears to have noticed a problem with bank angle indication and repeatedly indicated concern over the aircraft bank angle. These comments were presumably directed to the pilots and the commander in particular. He was an experienced flight engineer with 4,500 hours on the Boeing 747.

### **2.9.5 Crew performance**

The combination of actions of the three flight crew members did not result in an appropriate crew reaction to the systems failure encountered. In contrast the identical failure was competently handled by the crew departing Tashkent, albeit in very different circumstances amounting to day VMC.

Korean Air had established CRM training in 1986 based on an American model which was subject to review and development intended to produce a programme catering for the Korean culture. The investigating team visited the training facility in 2000 and observed training in progress. It was not possible in a short visit to assess the training techniques and quite naturally training was being delivered in the Korean language.

Following the Korean Air Boeing 747 accident on Guam in 1997, the airline started to implement changes aimed at improving operational safety. Since the Stansted accident Korean Air has introduced a vigorous review of flight crew selection, training and performance monitoring emphasising CRM issues. The target of these initiatives has been to achieve improved quality control of the operation. However, given the crew response to the system failure at Stansted and the

inevitable time required for training initiatives to achieve impact throughout the operation this initiative needs to be sustained.

It is recommended that:

Korean Air continue to update their training and Flight Quality Assurance programmes, to accommodate Crew Resource Management evolution and industry developments, to address issues specific to their operational environment and ensure adaptation of imported training material to accommodate the Korean culture.

[Safety Recommendation No 2003-62]

## 2.10 Dangerous Air Cargo (DAC)

ICAO Technical Instructions (Part 5 of the 2003-2004 edition Doc9284) put the onus on the aircraft operator to inform the State in which an aircraft accident has occurred of the dangerous goods carried, together with supplementary information, as soon as possible. However, the instructions do not define an addressee. The timely availability of information on DAC is an essential element in the accident site risk analysis, which has to be conducted by the agencies responding to the accident. The emergency services, particularly the fire services, will almost always be confronted with responding before detailed information on the cargo contents is available. They are therefore forced to make certain assumptions and to consider the worst case scenario. They are familiar with the hazards of burning aircraft, equip themselves accordingly and have limited exposure. The accident investigators and other supporting agencies could be exposed to the accident site for some days and the aircraft wreckage for some weeks or months. It is therefore appropriate for the information on DAC to be directed to the accident investigation authority of the state of occurrence.

It is recommended that:

ICAO Technical Instructions Part 7, chapter 4.6.1 be amended to, 'The operator of an aircraft carrying dangerous goods which is involved in an aircraft accident must, as soon as possible, inform the appropriate Authority in the State in which the aircraft accident occurred of the dangerous goods carried together with their proper shipping names, class and subsidiary risks for which labels are required, the compatibility group for Class 1 and the quantity and location on board the aircraft'.

[Safety Recommendation No 2003-65]

In this case, as the aircraft crashed close to the point of departure, the information on DAC was quickly available from the cargo handling company and the material type and volume was such that it was rendered benign by the impact.

In addition to the declared DG, there was other hazardous material in the cargo which did not fall into the category classified as DG and therefore required no specific DG packing or marking. This was a consignment of medical diagnostic kits containing small phials of 'Iodine 125' classified as 'Radioactive - Excepted Package'. Information on this material was not identified for several days because of the large volume and variety of paperwork associated with the cargo load. Although it was eventually established that the volume and nature of the material involved did not constitute a significant health threat its presence, detected before its nature was established, resulted in the site being evacuated and fuelled local concerns.

Given the difficulties associated with the timely transfer of information on DAC and the presentation of information on other cargo, the manifests being produced from a paper based system it is proposed that review take place of the methods employed to track airborne cargo.

It is recommended that:

ICAO consider an initiative to review the current methods of tracking air cargo and further consider improved systems, utilising electronic data storage and transmission, with a view to providing timely information on the cargo carried by any aircraft involved in an accident.

[Safety Recommendation No 2003-66]

## 2.11 Hazardous materials

The ICAO Hazards at Accident Sites Study Group has been tasked with developing a system for collecting data on hazardous materials used in aircraft construction to be encountered on aircraft accident sites and providing guidance on managing the associated risks. This requires a study of the potential health risks associated with the construction materials when mixed and modified by impact and/or fire. It is anticipated that the work of the study group will have been completed within two years.

It is recommended that:

The ICAO Hazards at Accident Sites Group is supported and resourced to enable it to meet its target date for delivery of the necessary data and risk management advice.

[Safety Recommendation No 2003-67]

NOTE FROM ICAO: ...the ICAO Study Group members are experts nominated by States and organisations to assist ICAO in progressing a task. An ICAO technical officer is assigned as a Secretary of the group to facilitate and co-ordinate its activities. The progress of such groups is very dependant on the input of members.

## 3 Conclusions

### (a) Findings

- 1 The aircraft was serviceable on the flight from Seoul to Tashkent.
- 2 On departure from Tashkent, the captain's Attitude Director Indicator (ADI) did not indicate the aircraft roll attitude correctly.
- 3 The actions of the crew to deal with the ADI fault on takeoff from Tashkent were prompt and effective.
- 4 During the subsequent flight to Stansted, the crew determined that the fault occurred with Inertial Navigation Unit No 1 selected as the source of attitude information for the captain's ADI.
- 5 The crew entered the fault into the Technical Log as detailed by the Fault Reporting Manual (FRM). Additionally at Stansted, the flight engineer gave a verbal brief to the Korean ground engineer including the information that the ADI worked correctly with the captain's Attitude and Compass Stabilization switch selected to ALT.
- 6 A copy of the aircraft Fault Isolation Manual (FIM) was not available to the KAL engineer at Stansted. Use of the FIM would have directed maintenance to replace INU No 1.
- 7 At Stansted, the KAL ground engineer identified a fault with the captain's ADI that was rectified by a UK avionics engineer but this had no impact on the ADI function.
- 8 There is no record of what the ground engineer entered into the Technical Log to clear the aircraft for flight.
- 9 There is no record of what the ground engineer verbally briefed the outbound crew regarding the rectification of the ADI fault.
- 10 A flight crew member from the outbound crew was in the cockpit when some of the rectification to the ADI was being carried out but there is no record of what he subsequently briefed to his fellow crew members.
- 11 The accident crew were properly licenced and qualified to operate the flight.

- 12 The aircraft on the accident flight was correctly loaded and was within the approved weight and centre of gravity limits.
- 13 There was nothing recorded on the CVR relating to the reported fault with the ADI, although there was also no record of the commander's departure brief which is normally given prior to engine start. The relevant briefs may have taken place more than 30 minutes before the impact and have been recorded over due to the limited 30 minute duration of the CVR record.
- 14 There were delays to the aircraft start and taxi due to factors outside the crew's control. These delays appeared to have caused some frustration to the commander.
- 15 The record from the CVR indicated that there was some confusion in the commander's mind, during taxi and after takeoff, as to the correct operation of the DME at Stansted.
- 16 The CVR indicated that the commander was basing his turn position after takeoff on a DME range rather than an alternative VOR radial.
- 17 The crew were given a frequency change after takeoff which was not required to be pre-notified although the frequency was available within Stansted ATC. This may have contributed to distract the first officer from his monitoring duties.
- 18 The captain's ADI indicated correctly in pitch during the accident flight.
- 19 Throughout the accident flight, the captain's ADI showed a near zero roll attitude.
- 20 Korean Air's Inertial Navigation Unit (INU) reliability data compared favourably with the manufacturer's global data.
- 21 During the accident flight, the ADI comparator warning activated on three separate occasions.
- 22 There was no audible acknowledgement from any crew member regarding these warnings.
- 23 The ADI comparator warning system appeared to work correctly.
- 24 Following the initial comparator warning, the visual warnings would have continued to display in front of each pilot until individually cancelled.
- 25 The warnings were individually cancelled prior to the final impact.
- 26 There was no evidence that the commander detected that the aircraft was at an extreme roll and pitch attitude.
- 27 The first officer either did not detect that the aircraft was at an extreme roll and pitch attitude or having identified the abnormal attitude was inhibited from bringing this to the attention of the commander.
- 28 There was a marked difference in age and experience between the commander and the first officer.
- 29 The flight engineer made several warning calls to indicate his awareness that there was a problem with bank indication and angle of bank.
- 30 With aggressive control inputs the aircraft was capable of recovery from its extreme, unusual attitude two seconds (at 1,920 feet) after reaching its maximum altitude without exceeding the limit load factor of +2g.
- 31 The operator had not deployed its own full-time engineer at Stansted.
- 32 The ground engineer had insufficient technical knowledge of the ADI/INU interface for troubleshooting and defect rectification.



33 Korean Air has introduced a number of measures since the accident to improve operational quality assurance and control.

**(b)Causal Factors**

The following causal factors were identified:

- 1 The pilots did not respond appropriately to the comparator warnings during the climb after takeoff from Stansted despite prompts from the flight engineer.
- 2 The commander, as the handling pilot, maintained a left roll control input, rolling the aircraft to approximately 90° of left bank and there was no control input to correct the pitch attitude throughout the turn.
- 3 The first officer either did not monitor the aircraft attitude during the climbing turn or, having done so, did not alert the commander to the extreme unsafe attitude that developed.
- 4 The maintenance activity at Stansted was misdirected, despite the fault having been correctly reported using the Fault Reporting Manual. Consequently the aircraft was presented for service with the same fault experienced on the previous sector; the No 1 INU roll signal driving the captain's ADI was erroneous.
- 5 The agreement for local engineering support of the Operator's engineering personnel, was unclear on the division of responsibility, resulting in erroneous defect identification, and mis-directed maintenance action.

## 4 Safety Recommendations

The following safety recommendations were made during the course of the investigation. It is recommended that:

**4.1 Safety Recommendation No 2003-62:** Korean Air continue to update their training and Flight Quality Assurance programmes, to accommodate Crew Resource Management evolution and industry developments, to address issues specific to their operational environment and ensure adaptation of imported training material to accommodate the Korean culture.

**4.2 Safety Recommendation No 2003-63:** Korean Air continue to review its policy and procedures for maintenance support at international destinations with a view to deploying sufficient of its own full-time engineers at the outstation or delegating the entire task to another operator or third-party maintenance organisation locally-based at the destination (Full Technical Handling). If neither of these approaches is practicable then the support arrangements must be detailed and of such clarity as to preclude confusion.

**4.3 Safety Recommendation No 2003-64:** Korean Air review its policy and procedures to ensure that a copy of the relevant pages of the Technical Log and any other transit certification documents are left on the ground at the point of departure.

**4.4 Safety Recommendation No 2003-65:** ICAO Technical Instructions Part 7, chapter 4.6.1 be amended to, 'The operator of an aircraft carrying dangerous goods which is involved in an aircraft accident must, as soon as possible, inform the appropriate Authority in the State in which the aircraft accident occurred of the dangerous goods carried together with their proper shipping names, class and subsidiary risks for which labels are required, the compatibility group for Class 1 and the quantity and location on board the aircraft'.

**4.5 Safety Recommendation No 2003-66:** ICAO consider an initiative to review the current methods of tracking air cargo and further consider improved systems, utilising electronic data storage and transmission, with a view to providing timely information on the cargo carried by any aircraft involved in an accident.

**4.6 Safety Recommendation No 2003-67:** The ICAO Hazards at Accident Sites Study Group is supported and resourced to enable it to meet its target date for delivery of the necessary data and risk management advice.

## Appendix A - B747 Transit Checklist

Appendix A

Appendix B  
Figures 1 and 2KOREAN AIR  
B747 TRANSIT CHECK LIST

A/C No. HL		STATION		DATE		KEY IN	
W/S	DD/MM	FROM	TO	EMPLOYEE	NUMBER		
DESCRIPTION						CHECKED BY	
<b>1. GENERAL</b>							
1) Check the A/C for parking & ground safety condition. ; Wheel chocks, gear lock pins & door levers, static grounds, fire extinguishers, control surface locks, equipment / obstructions removed, tow bar, etc.						T3	
2) Check the maintenance & flight log and rectify all flight squawk items.						T1	
<b>2. COCKPIT</b>							
1) Check the crew & passenger oxygen system pressure and hydraulic fluid quantity indicator in normal range, and service as required. (hydraulic fluid spec : SKYDROL LD4)						T2	
2) Check engine oil level and service as required within 2 hours after engine shutdown. (spec : ESSO 3380) Add/Total Q'TY : # 1 ___ / ___ # 2 ___ / ___ # 3 ___ / ___ # 4 ___ / ___						T2	
<b>3. ENGINE &amp; NACELLE</b>							
1) Check engine inlet area, fan blades & rotor spinner, exhaust area & NO.5 stage turbine blades, cowling & fairings, drain holes & masts for condition, obstruction, fluid leaks & FOD.						T2	
2) Check the strut / nacelle access panels and the engine fire extinguisher bottle discharge indicator disks are intact.						T2	
3) Check the engine fan blade shrouds for shingling. (JT8D-7R4G2 engine only)						T3	
4) Check thrust reversers are in stowed position.						T3	
5) Check the indication stripe between strut and AFT fairing for proper alignment. If misaligned, inspect the midspar fuse pin and attachment fitting for integrity.						T3	
<b>4. L/G &amp; WWF</b>							
1) Check nose, wing & body landing gears, wheel wells, wheels, tires, doors, brakes and linkages for damage, leaks, condition & leakage						T2	
2) Check shock struts and extensions for proper extension, leaks and condition.						T2	
3) Wipe the exposed chrome portion of the strut piston with a clean cloth moistened with MIL-H-5606 hydraulic fluid per strut nameplate, and wipe clean with a dry cloth.						T3	
<b>5. FUSELAGE, WING &amp; EMPENNAGE</b>							
1) Check the fuselage exterior surfaces including cargo compartments, radome, access panels & doors, and electronic compartments for condition.						T2	
2) Check the fuselage openings & fixtures including pitot-static probes, static ports & total air temperature probes, antennas, drain masts & drains, ram air inlets & outlets, pressurization out-flow opening, and angle of attack sensor for condition & safety.						T2	
3) Check external lighting fixtures for damage & condition. a) Clearance lights (Runway turnoff lights)      b) Navigation lights c) Anti-collision beacons / strobe lights      d) Landing lights						T2	
4) Check oxygen blow-out disks and APU fire extinguisher disks for presence.						T2	
5) Check the wing exterior surfaces including wing tip surfaces, tank vents, surge tank indicators, T/E flaps & ailerons, L/E flaps, static dischargers, and access panels & doors for damage, leakage, and condition.						T2	
6) Check the empennage exterior surfaces including vertical fin & rudders, horizontal stabilizer & elevators, static dischargers, and access panels & doors for damage & condition.						T2	
<b>6. DISPATCH</b>							
1) Check the fuel quantity indicator in normal range.						T2	
2) Accomplish final walk around inspection. a) Check all access doors, service panels, cargo compartment doors, water fill & drain caps, toilet drain plugs are safely closed & locked. b) Ensure that the landing gear safety lock pins are removed before flight.						T1	

REV 10, 34 (38.06)

KAL-KR-701 (215 x 297 mm)

PAGE 1 OF 1

## Appendix B - Figures 1 and 2 - Flight Director Indicator Display

Appendix B  
Figures 1 and 2

### Flight Director Indicator 329B-SJ Display

under a test condition to display warning flags

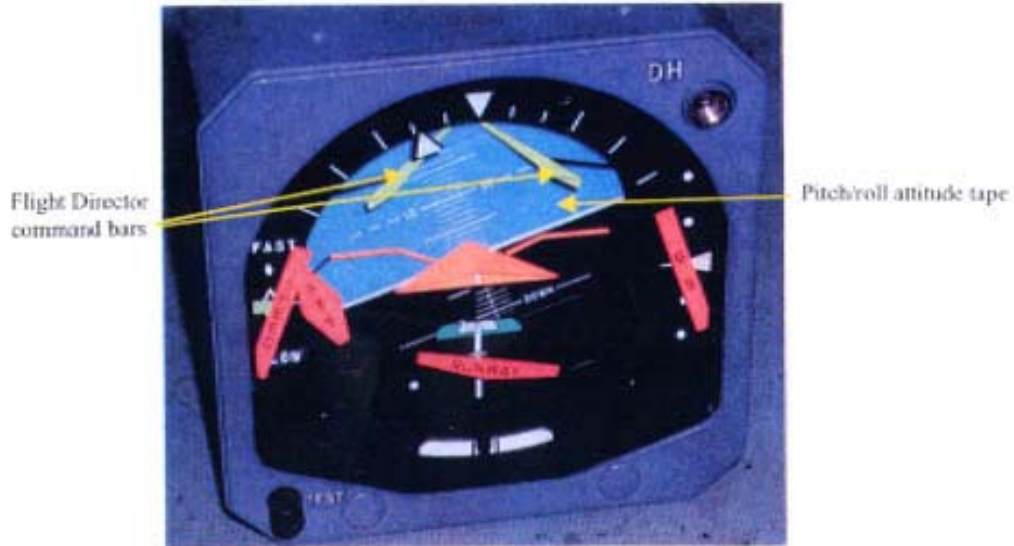

(note: On HL-7451 the ATT flag is labelled GYRO)

Figure 1

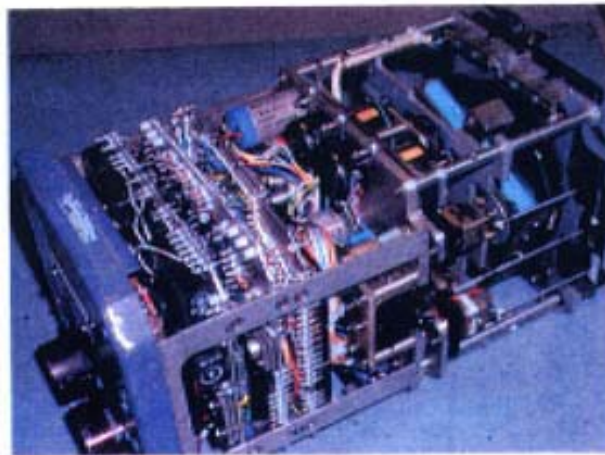

General view of indicator with outer protective cover removed

Figure 2

## Appendix C - Functional diagram of FDI

OUTLINE FUNCTIONAL DIAGRAM OF COLLINS FLIGHT DIRECTOR INDICATOR, 329B-8J, Part No. 772-5005-001

(Captain's Position)

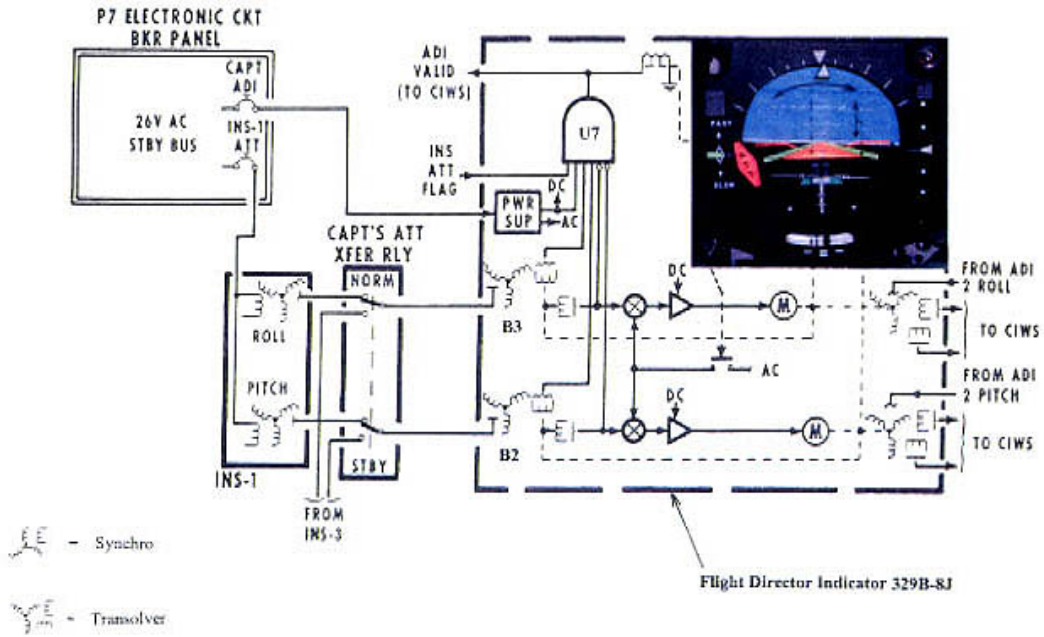

Appendix C

### Appendix D - Figure 1 - Central Instrument Warning System Schematic

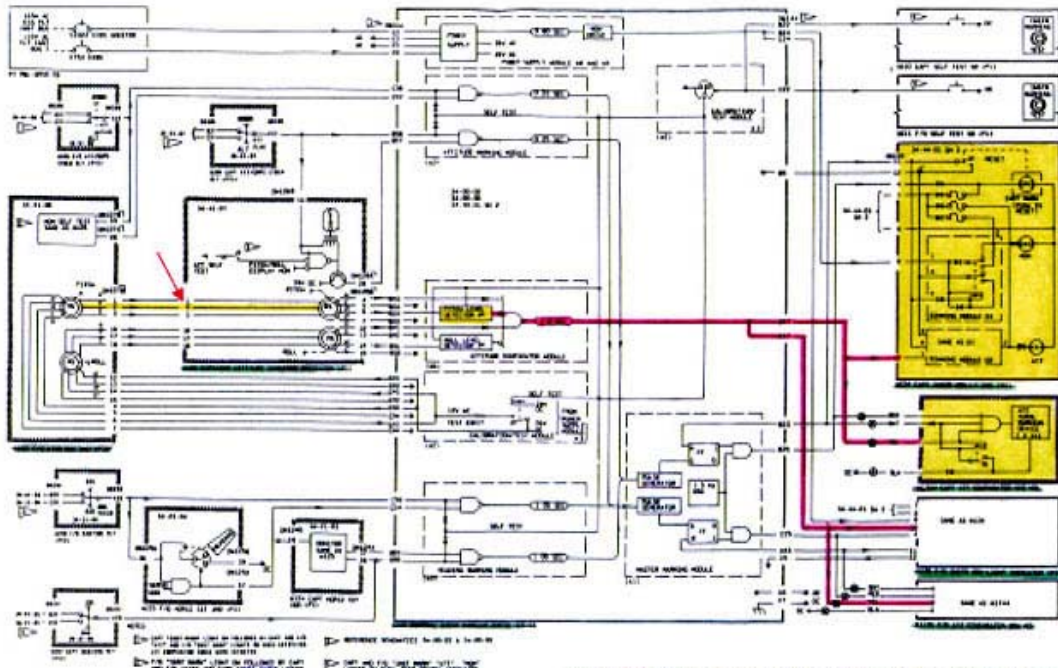

**CENTRAL INSTRUMENT WARNING SYSTEM SCHEMATIC**  
(taken from KoreanAir Boeing 747 wiring manual)

Location of 'displaced' pin No 2, plug J1, arrowed

Appendix D  
Figure 1

## Appendix D - Figure 2 - Section of Indicator Circuit Diagram

Appendix D  
Figure 2



Rear view of 329B-8J Flight Director Indicator

Illustrating location of multi-pin connectors J1 and J2

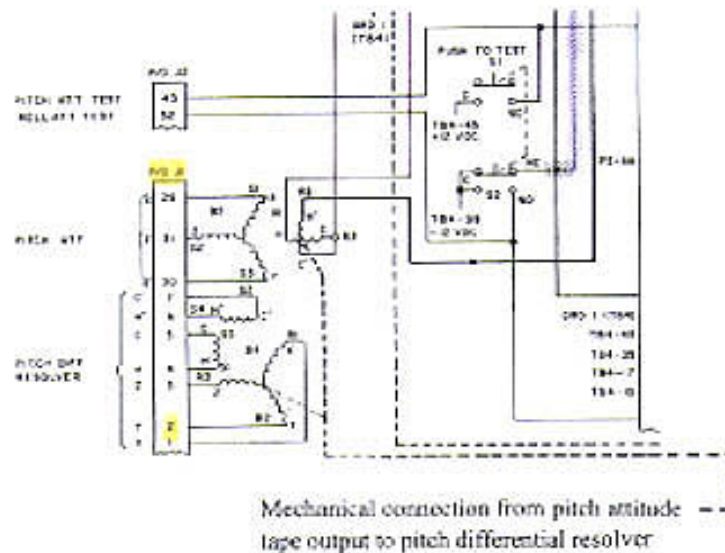

Section of Indicator Circuit Diagram Showing Internal Wiring from Connector J1 pin 2

### Appendix E - Figure 1 - Drawing of INU

Appendix E  
Figure 1

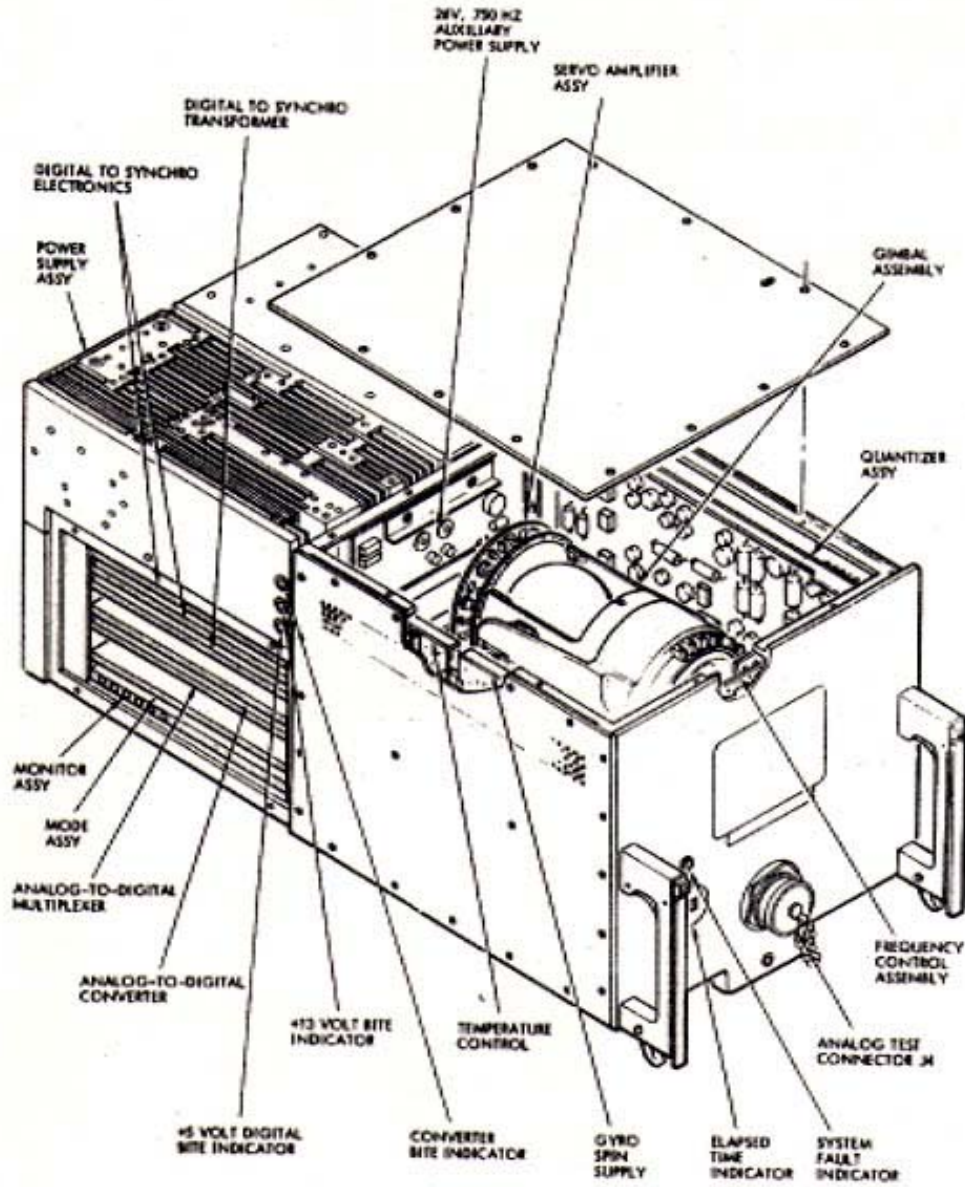

Inertial Navigation Unit (INU)



**Appendix E - Figure 2 - Attitude interface and Attitude Repeater circuit boards**

Appendix E  
Figure 2

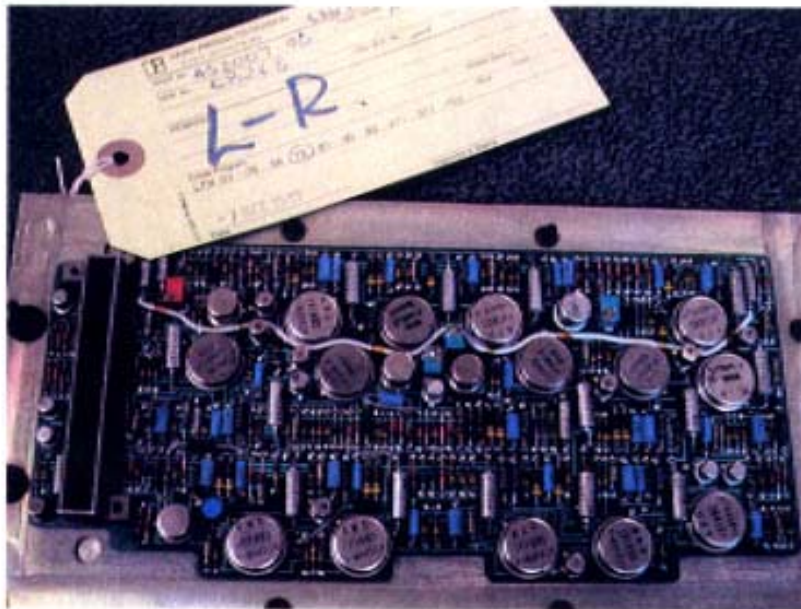
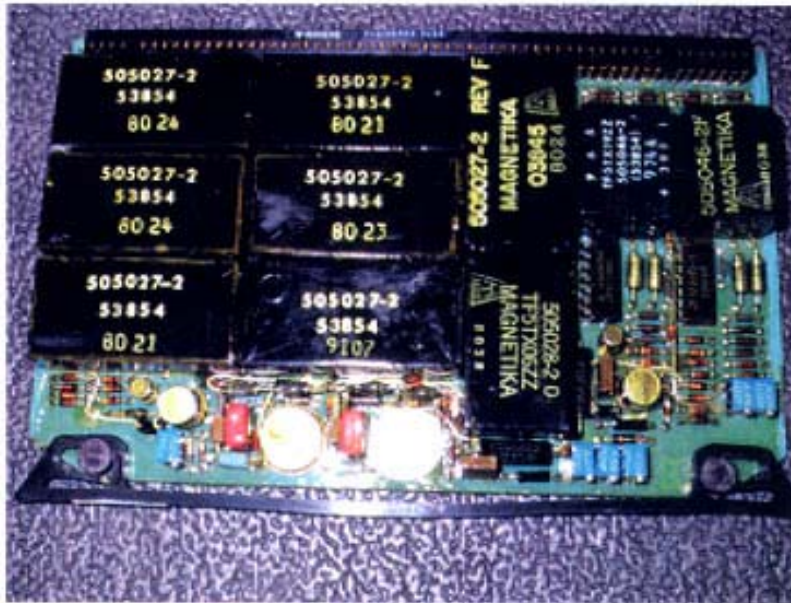
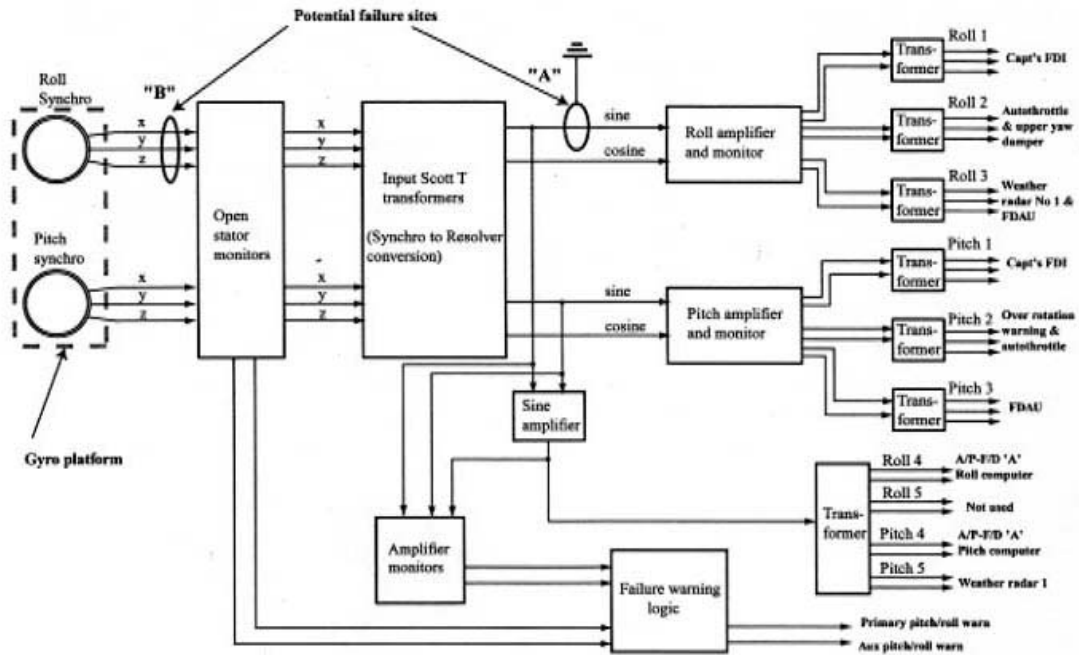

FIGURE 2 Attitude Interface (top) and Attitude Repeater circuit boards

Appendix E - Figure 3 - Schematic of INU attitude signal flow

**SCHEMATIC DIAGRAM OF INU ATTITUDE SIGNAL FLOW**  
 (NOTE: Output functions are shown for INU No 1)



Appendix E  
 Figure 3

Appendix F - Figure 1 - UK AIP entry for Dover 6R SID

Appendix F  
Figure 1

AD 2-EGSS-6-4 (2 Dec 99)

UK AIP

DOVER SIDs/LYDD SIDs

LONDON STANSTED

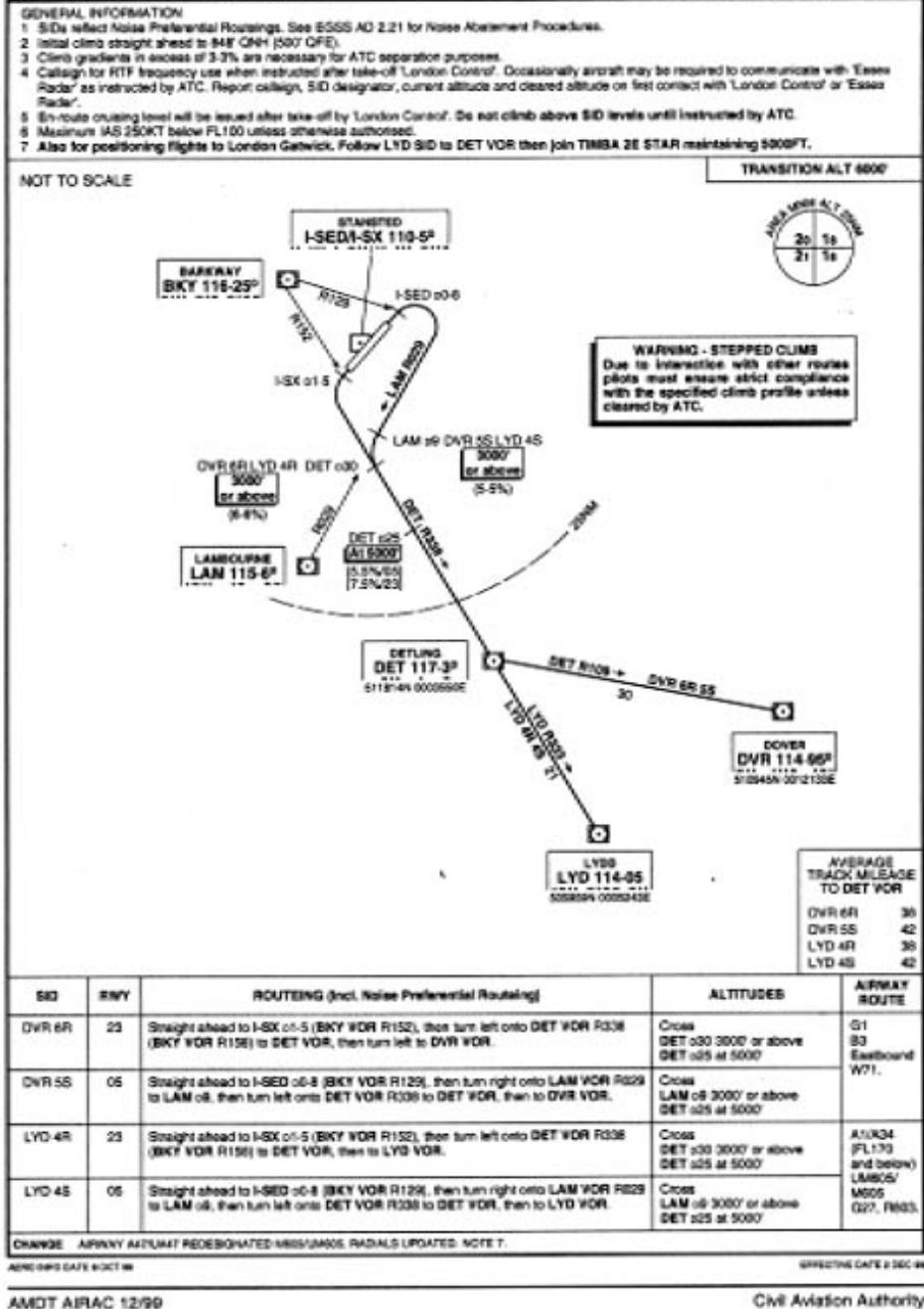

## Appendix F - Figure 2 - Jeppesen plate 30-3D for Dover 6R SID

**Illustration not Available**

Fss.aero was unable to obtain permission from Jeppesen-Sanderson, Inc. to reproduce this copyrighted chart.

Please see the FAQ for easy work-arounds.

Jeppesen-Sanderson can be reached at:

[www.jeppesen.com](http://www.jeppesen.com)

55 Inverness Drive East  
Englewood, CO 80112-5498

Appendix F - Figure 3 - UK AIP entry for Stansted ILS/DME Runway 23

Appendix F  
Figure 3

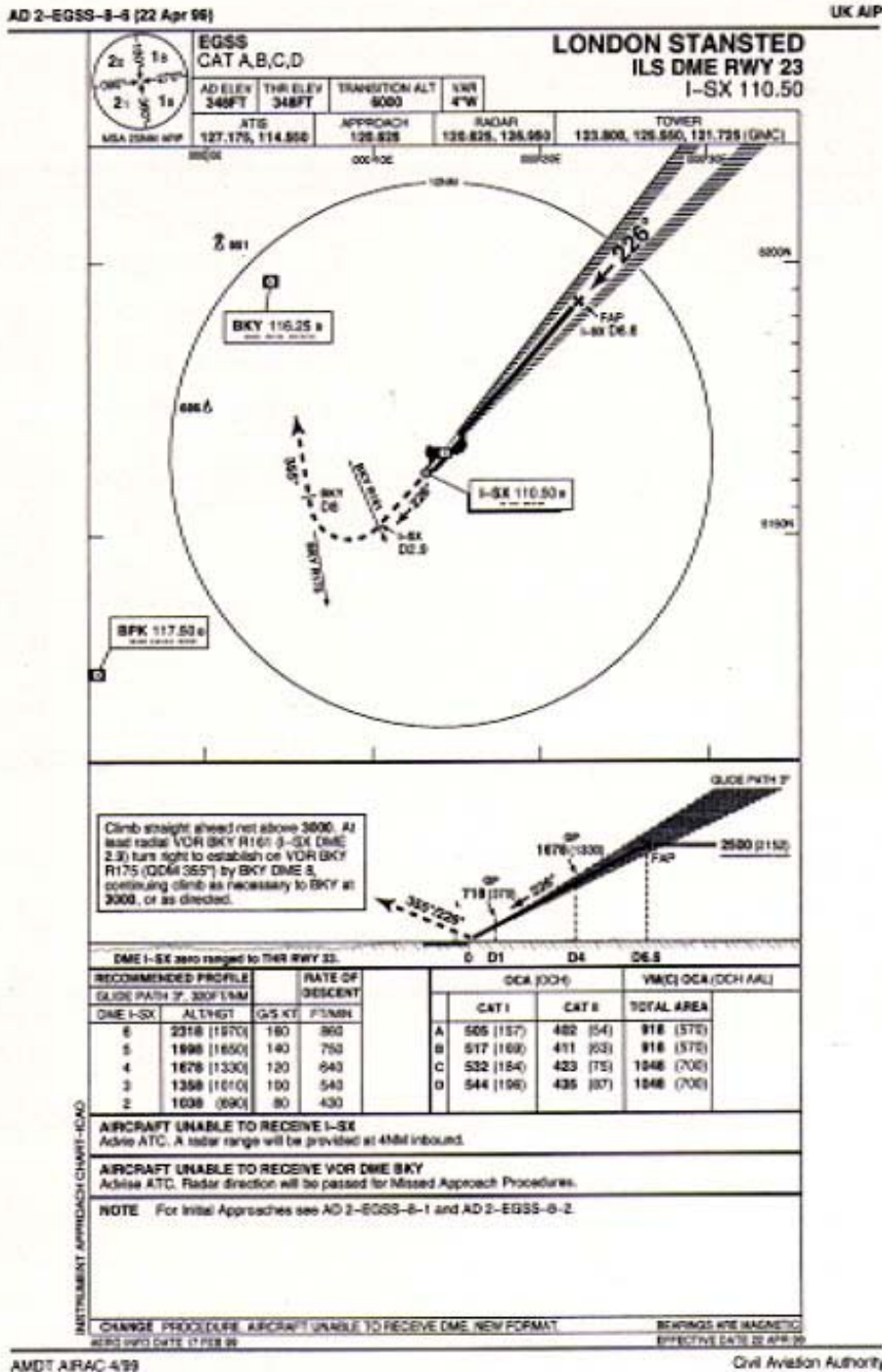

Appendix F - Figure 4 UK AIP entry for Stansted Aerodrome Chart

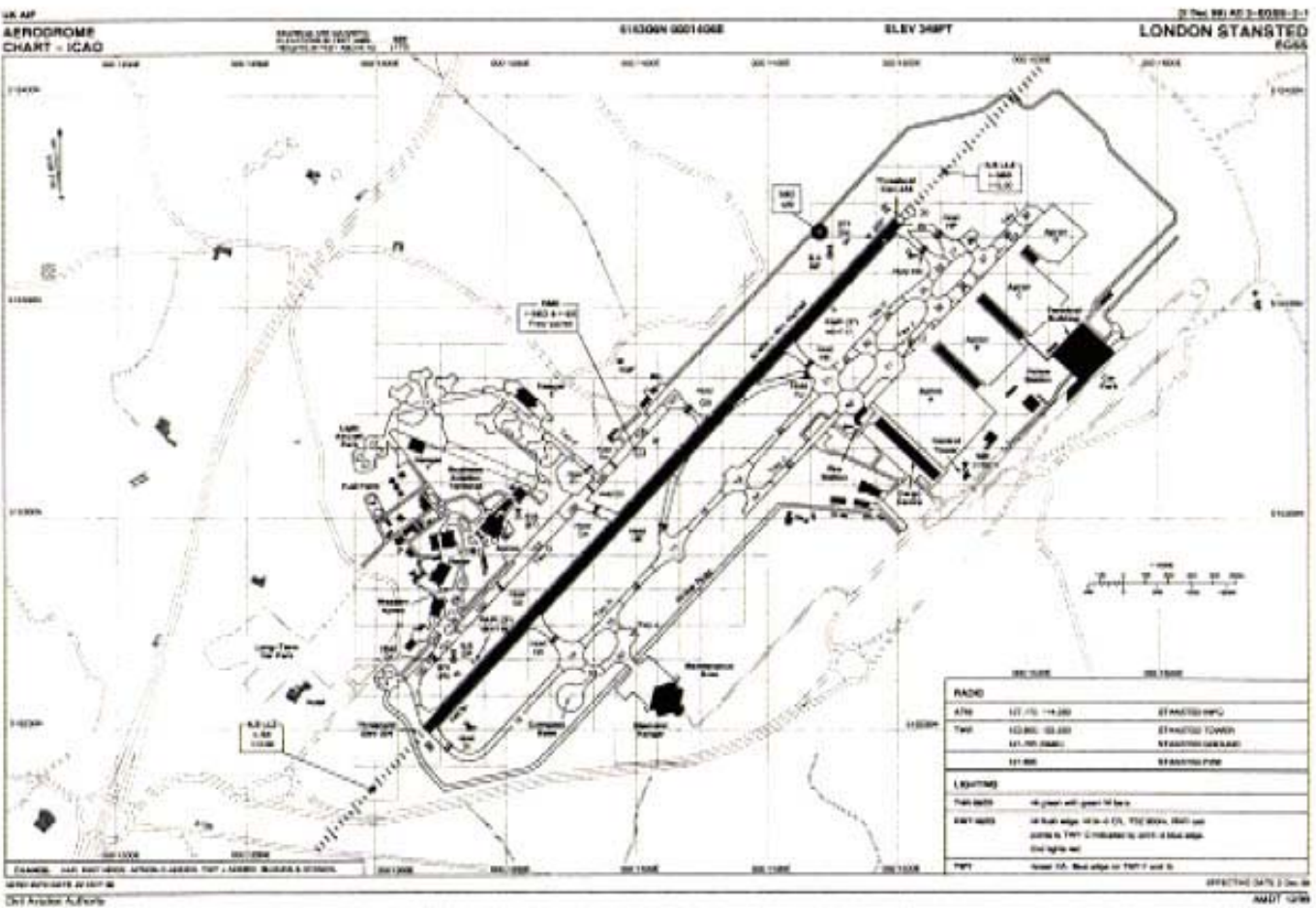

Appendix F  
Figure 4

**Appendix G - Figures 1 - 2 and 3 - FDR Unit**

Appendix G  
Figures 1, 2, 3



FDR unit (crash protected enclosure normally located on right hand side (front of unit))



Crash Protected enclosure (showing separation of the two halves)



Magnetic tape inside crash protection

**Appendix G - Figure 4 - CVR unit as found in wreckage**

Appendix G  
Figure 4



CVR unit



## Appendix H - Page 1 - CVR transcript extracts

KAL 747 Accident on 22 December 1999 Provisional CVR Transcript  
 Italics denote translation from Korean language, brackets denote uncertain words  
 p1 = Captain p2 = First Officer F Eng = Flight Engineer G Eng = Korean Ground Engineer on-board aircraft

TIME	TO END	ATC UTC	SOURCE	ATC	SOURCE	INTELLIGENCE	COMMENTS
31:11.4	02:03.5	18:35.5	stansted tower	Korean eight five zero nine surface wind one nine zero one eight knots clear take off runway two three			
31:17.4	01:57.5		KAL8509 (p2)	Clear to take off runway two three koreanair eight five zero nine			
					p1	CHAM	
					p1	<i>it is strange the surface looks damp but is slippery</i>	
				OTHER ATC TRANSMISSIONS	p2	Clear for take off	
					p1	CHA - GULO GAB NI DA Now Rolling	
					p1	body gear steering	
					F Eng	body gear steering	
					F Eng	Compass cross check	
31:45.0	01:29.9				F Eng	time check three seven	
					F Eng	Before take off check list complete	
31:45.0	01:29.9						sound of engine power increase
					F Eng	stabilised -	
					p1	set take off thrust	
					F Eng	set	
					F Eng	(reduced) thrust	
31:57.0	01:17.8				F Eng	Check	switch noise
32:02.5	01:12.4				P2	eighty knots	
					p1	roger	

Appendix H

## Appendix H - Page 2 - CVR transcript extracts

KAL 747 Accident on 22 December 1999 Provisional CVR Transcript  
 Italics denote translation from Korean language, brackets denote uncertain words  
 p1 = Captain p2 = First Officer F Eng = Flight Engineer G Eng = Korean Ground Engineer on-board aircraft

TIME	TO END	ATC UNIT	SOURCE	ATC	SOURCE	INTELLIGENCE	COMMENTS
32:10.0	01:04.9			OTHER ATC TRANSMISSIONS	P2	v one rotate	
32:12.7	01:02.2						noise(maybe door banging)
32:16.4	00:58.5				p2	V two	
32:16.8	00:58.1						two noises(maybe trim movement)
32:17.8	00:57.1						click
32:18.6	00:58.3						noise (seat moving)
32:20.4	00:54.5				P2	positive climb	
					P1	gear up	
					P2	gear up	
					P1	set IAS	
					P2	IAS	
32:28.5	00:46.4				p1	ah	
					p1	<i>IL JECOM one decimal</i>	
					p1	<i>CHUM NA</i>	means I didn't expect this
32:33.0	00:41.0				P2	passing nine hundred feet	
32:35.0	00:39.9						warning starts
32:36.7	00:38.2						warning ends
32:38.5	00:36.4				p1	<i>we should turn at one point five DME</i>	(sounds three times)
32:41.4	00:33.5				p2	yes sir	
32:44.2	00:30.7				p1	<i>DME not working</i>	warning starts
32:45.3	00:29.6						warning ends
32:45.4	00:29.5				p2	<i>one five eight</i>	(sounds twice)
					p1	eh?	
32:46.8	00:28.1				p2	heading standby air	
32:48.8	00:28.1				p2	heading one five eight	

CVR Transcript Extract

Page 2 of 3

Appendix H

## Appendix H - Page 3 - CVR transcript extracts

KAL 747 Accident on 22 December 1999 Provisional CVR Transcript  
 Italics denote translation from Korean language, brackets denote uncertain words  
 p1 = Captain p2 = First Officer F Eng = Flight Engineer G Eng = Korean Ground Engineer on-board aircraft

TIME	TO END	ATC UNIT	SOURCE	ATC	SOURCE	INTELLIGENCE	COMMENTS
32:51.0	00:23.9						warning starts
32:53.4	00:21.5		stansted	Korean eight five zero nine contact london			
			tower	one one eight decimal eight two good night			
32:54.1	00:20.8				F Eng	<i>BANK AN MEOG NE Bank is not working</i>	
32:57.0	00:17.9						warning ends
32:58.0	00:16.9				F Eng	Bank Bank	(sounds nine times out off as tenth chime begins)
32:59.4	00:15.5		KAL8509	one one eight eight two koreanair eight five			
33:02.4	00:12.5		(p2)	zero nine			
33:03.3	00:11.8				p1	YA (eh you)	two click noises
33:04.7	00:10.2				F Eng	Standby Indicator (DO) also not working	
33:08.4	00:08.5					(OH)	mechanical noise
33:08.0	00:06.9				p1	Request Radar vector	
33:10.0	00:04.9				p1	YA (eh you)	static noise??
33:10.5	00:04.4						
33:11.3	00:03.7				?	??	increasing wind noise
33:11.6	00:03.3						
33:13.4	00:01.5				F Eng	OY Bank	
33:14.9	00:00.0						end

Appendix H

## Appendix I - M-cab - Summary of runs - page 1

## Appendix I

**M-cab – Summary of Runs****Simulator Log for the Morning of 2-8-2000 (Full Backdrive Simulation):**

The morning session consisted of 14 cases, all using the full backdrive (No Pilot Interaction) scenario. The results of each case are identical and are shown in Appendix I, Figures 1 and 2.

**Simulator Log for the Afternoon of 2-8-2000 (Pilot Interaction Simulations):**

**Note:** The pilot flying the manoeuvre was in the right seat for each case. All cases except for the last two (23 and 24) were backdriven with the pilot taking over at the designated recovery point. Cab motion was used for all but the last two cases.

Case #	Clock Time	Comments	Minimum Height (Feet)	Maximum g's	Maximum Velocity (KCAS)
1	13:03	Recover From 45 Deg. Bank	-	1.2	-
2	13:05	Recover From 60 Deg. Bank	2500	-	-
3	13:07	Recover From Peak Altitude	2250	1.6	-
4	13:08	Recover From Peak Altitude + 2 Seconds RUN NOT VALID, REDO AS CASE 5	-	-	-
5	13:09	Recover From Peak Altitude + 2 Seconds	1920	1.7	-
6	13:11	Recover From Peak Altitude + 5 Seconds	1000	2.75	-
7	13:14	Recover From Peak Altitude + 7 Seconds	640	4.0	-
8	13:18	Recover From Peak Altitude	2280	1.6	-
9	13:19	Recover From Peak Altitude + 5 Seconds	1100	3.5	-
10	13:21	Recover From Peak Altitude + 7 Seconds	770	3.5	-
11	13:22	Recover From Peak Altitude + 7 Seconds With Rudder Pedal	1040	3.0	-
12	13:27	Recover From Peak Altitude	2240	-	-

## Appendix I - M-cab - Summary of runs - page 2

Appendix I  
(cont)

Case #	Clock Time	Comments	Minimum Height (Feet)	Maximum g's	Maximum Velocity (KCAS)
13	13:29	Recover From Peak Altitude + 5 Seconds Stick Shaker Fired During Recovery	1450	3.0	-
14	13:30	Recover From Peak Altitude + 7 Seconds Stick Shaker Fired During Recovery	660	4.0	-
15	13:31	Recover From Peak Altitude + 7 Seconds With Rudder Pedal	720	3.8	-
16	13:35	Recover From Peak Altitude	2360	3.0	-
17	13:37	Recover From Peak Altitude + 5 Seconds	1390	2.5	260
18	13:38	Recover From Peak Altitude + 7 Seconds	820	3.2	280
19	13:40	Recover From Peak Altitude + 7 Seconds With Rudder Pedal	560	4.0	300
20	13:42	Recover From Peak Altitude + 7 Seconds With Rudder Pedal	520	3.7	290
21	13:43	Recover From Peak Altitude + 7 Seconds With Rudder Pedal	720	4.0	280
22	13:47	Recover From Peak Altitude + 8 Seconds Aircraft Not Recovered / Ground Impact	-	-	-
23	13:50	Full Backdrive (No Pilot Interaction) AAIB Videotaping FlightViz M-Cab Motion OFF	-	-	-
24	13:52	Full Backdrive (No Pilot Interaction) AAIB Videotaping FlightViz M-Cab Motion OFF	-	-	-

Appendix I, Figures 3 and 4 and Appendix I, Figures 5 and 6 show runs 3 and 5 respectively.

Appendix I - Figure 1 - M-cab Full backdrive profile

Appendix I  
Figure I

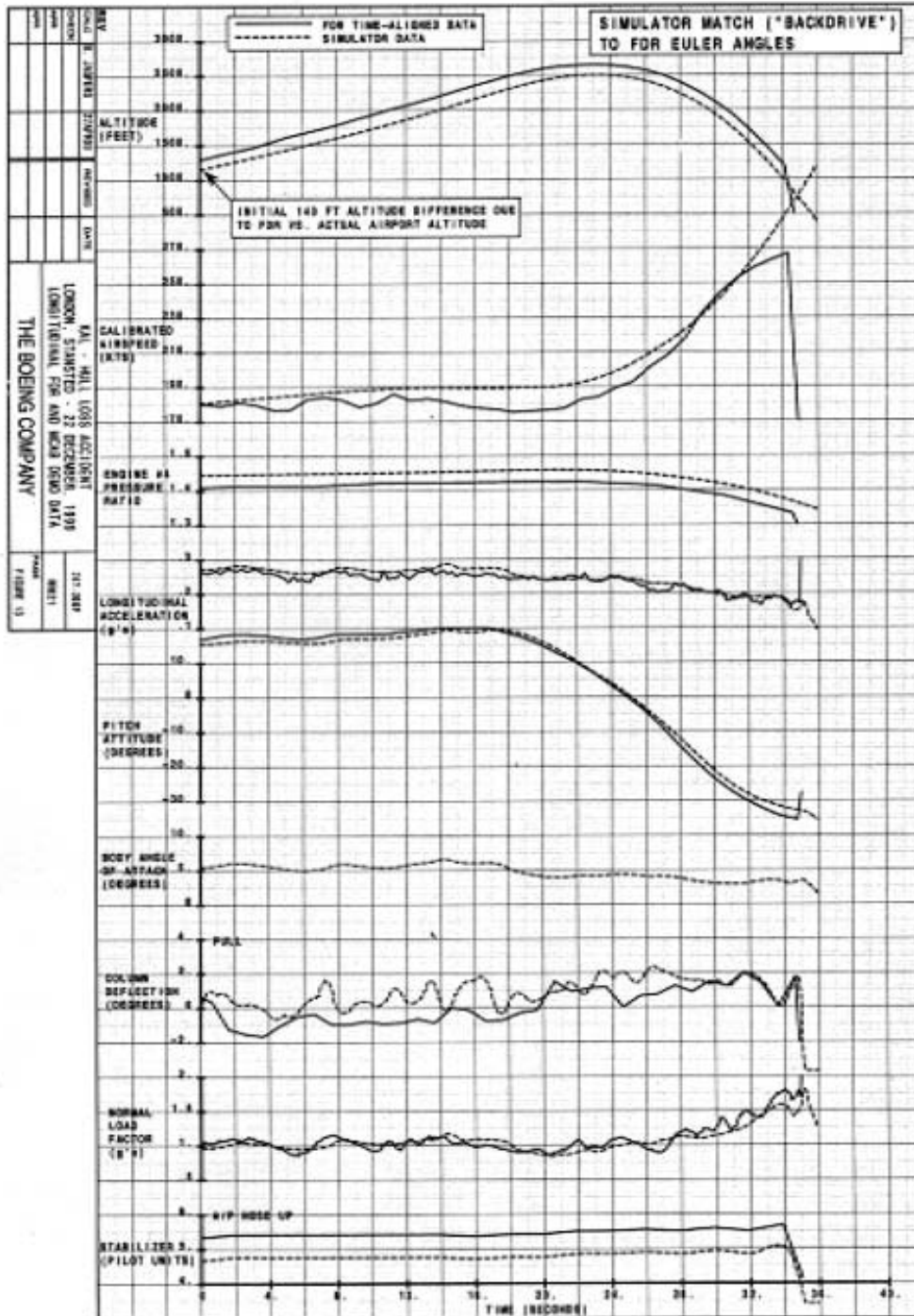

Appendix I - Figure 2 - M-cab Pilot interaction profile

Appendix I  
Figure 2

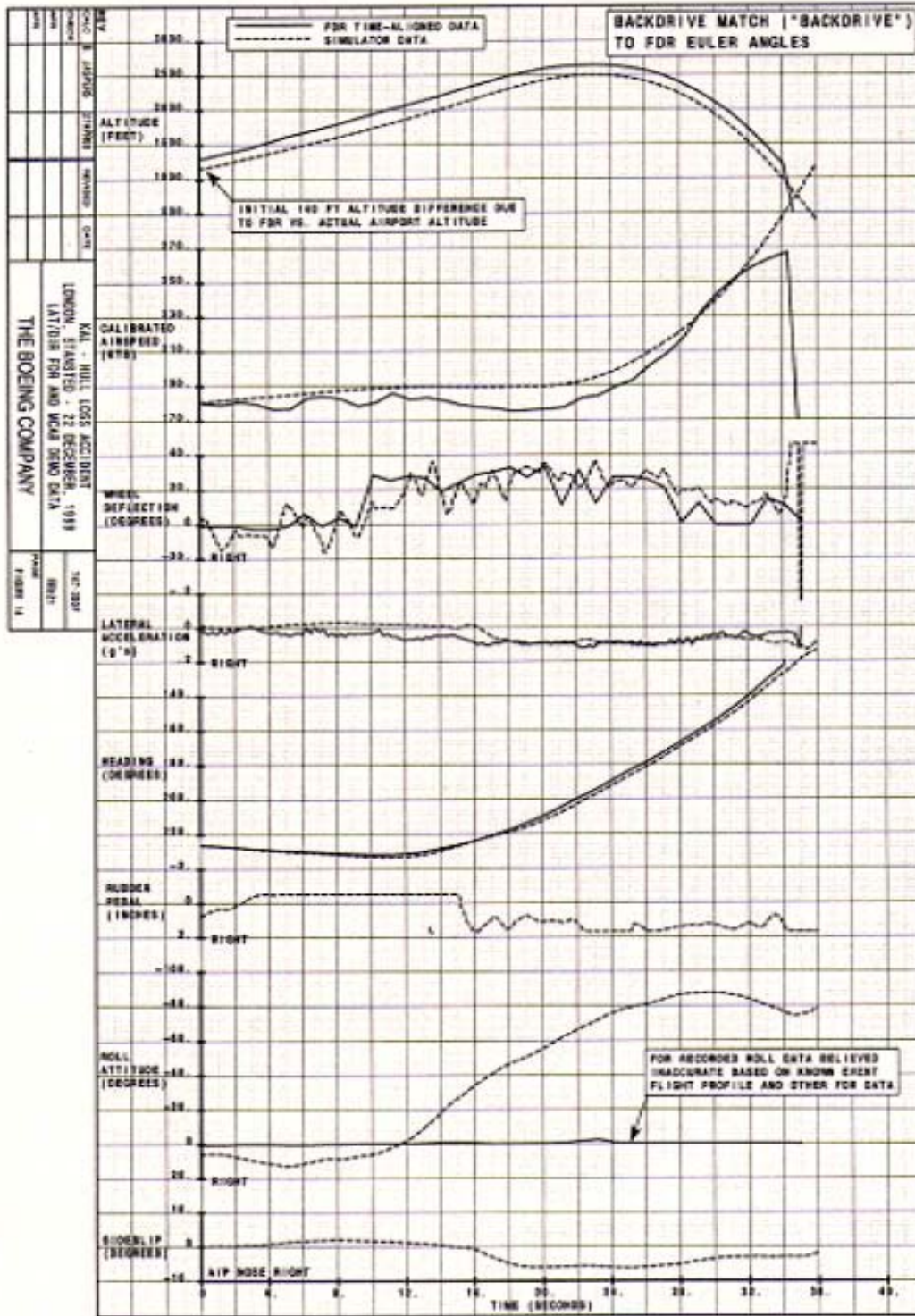

Appendix I - Figure 3 - M-cab Pilot interaction profile

Appendix I  
Figure 3

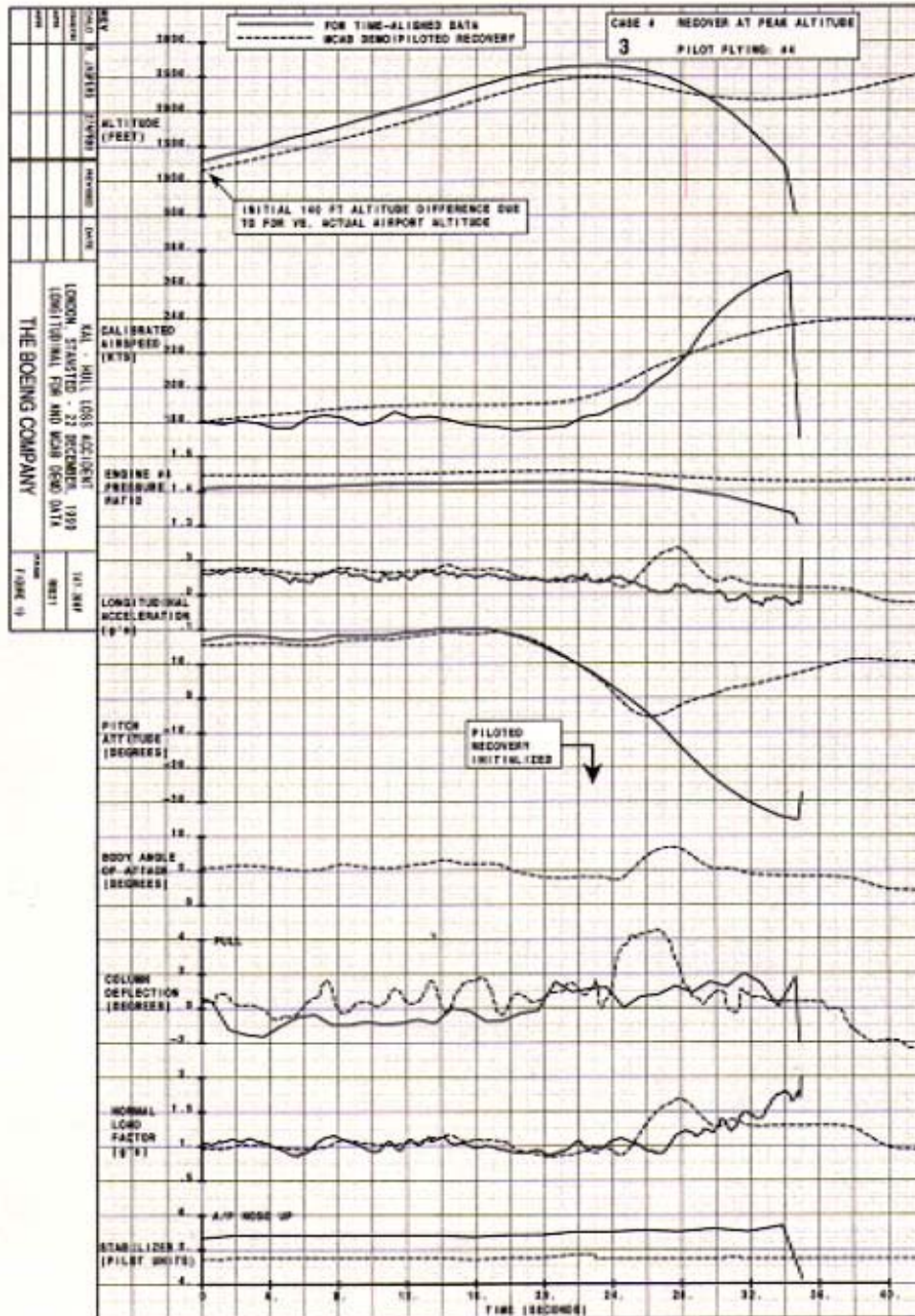



Appendix I - Figure 4 - M-cab pilot interaction profile

Appendix I  
Figure 4

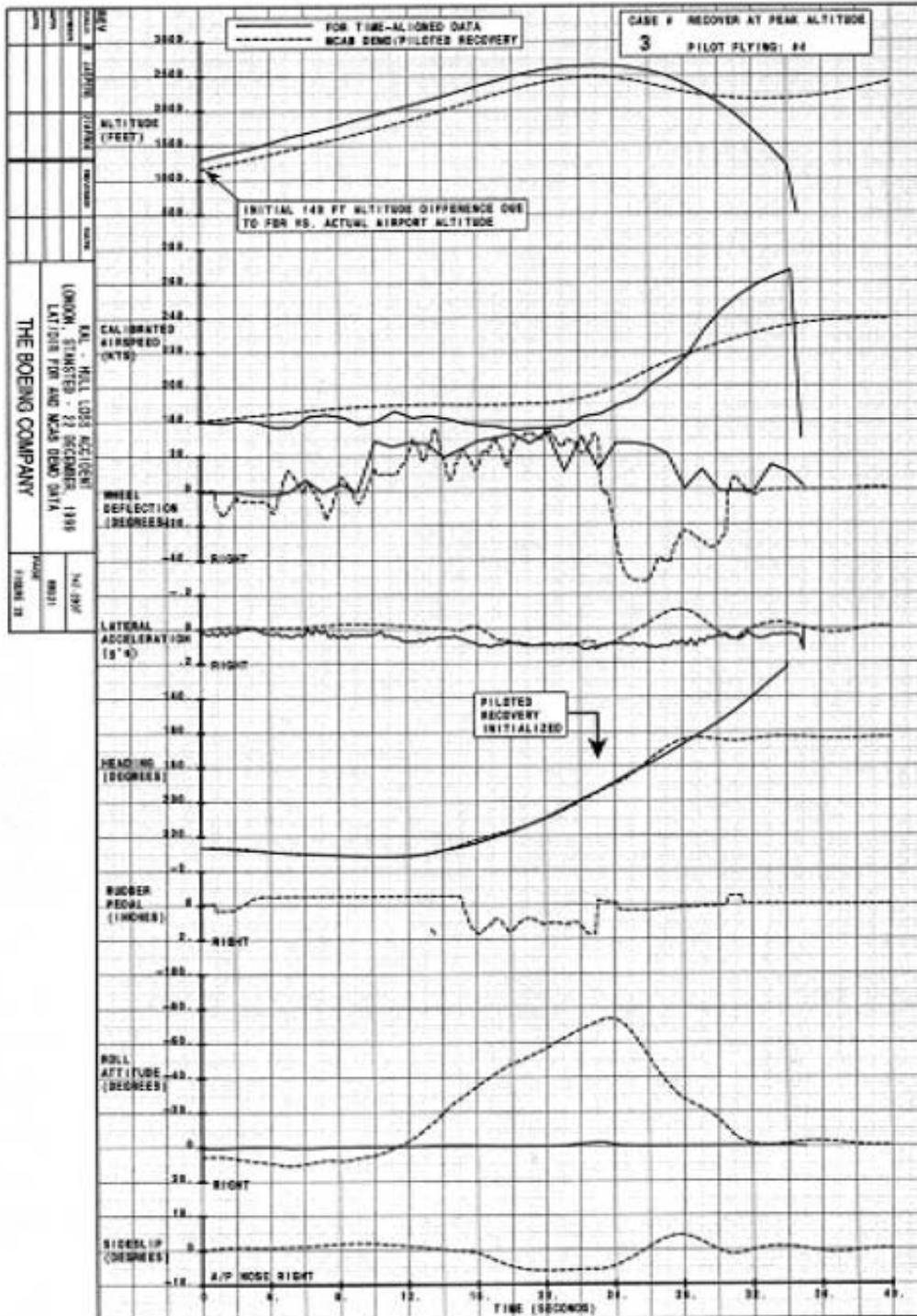

Appendix I - Figure 5 - M-cab Pilot interaction profile

Appendix I  
Figure 5

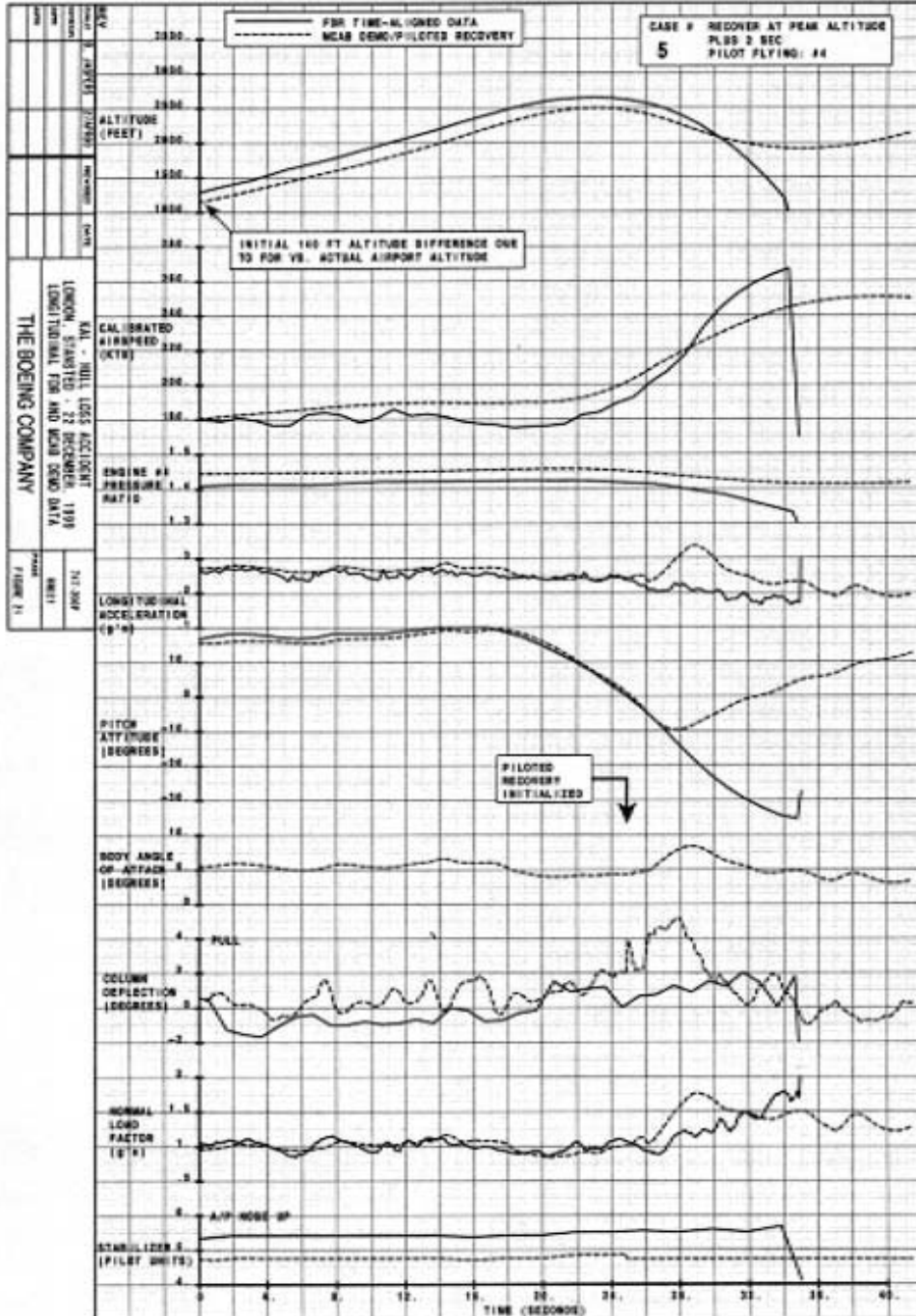

Appendix I - Figure 6 - M-cab Pilot interaction profile

Appendix I  
Figure 6

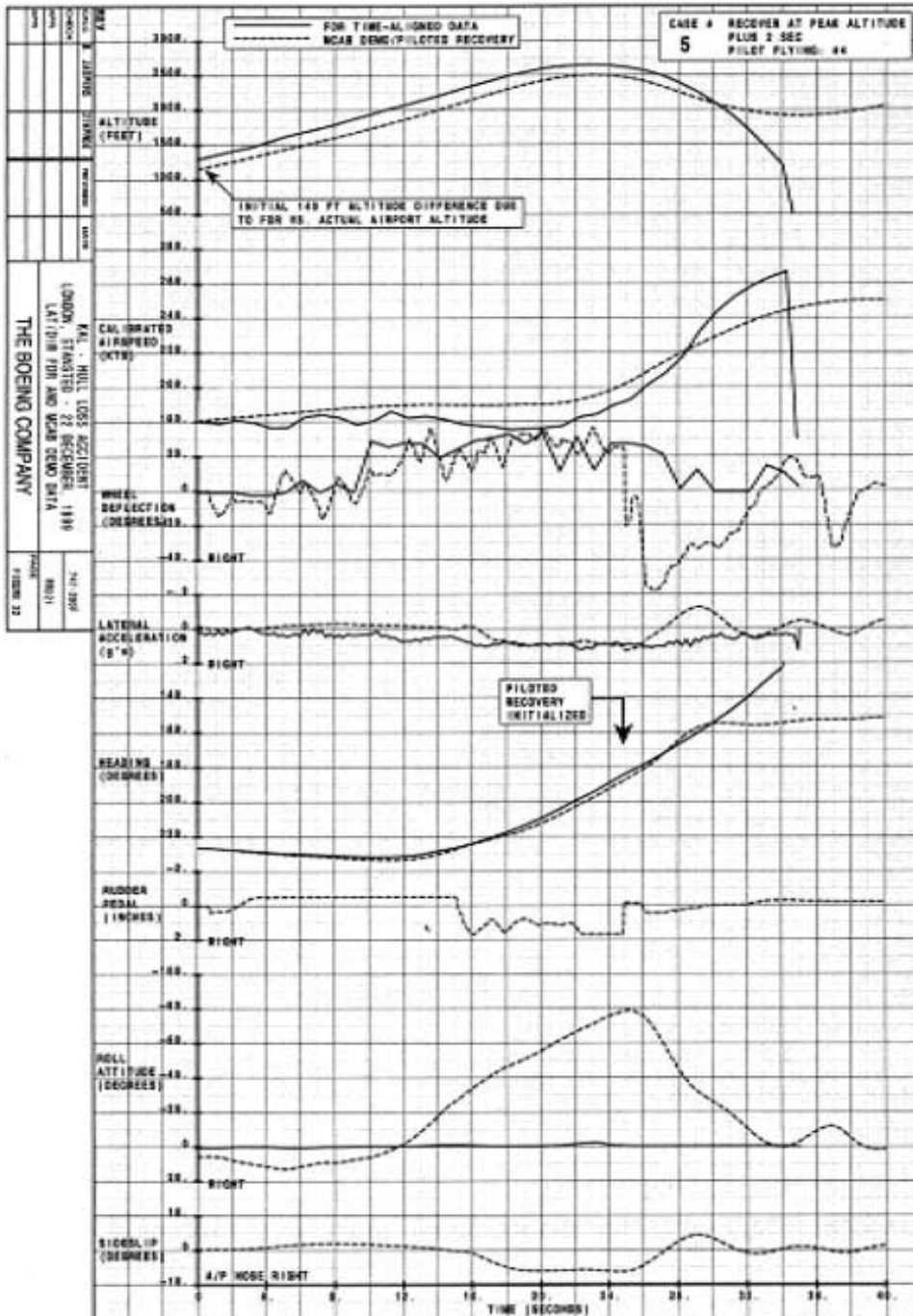

Appendix J - FDR plot

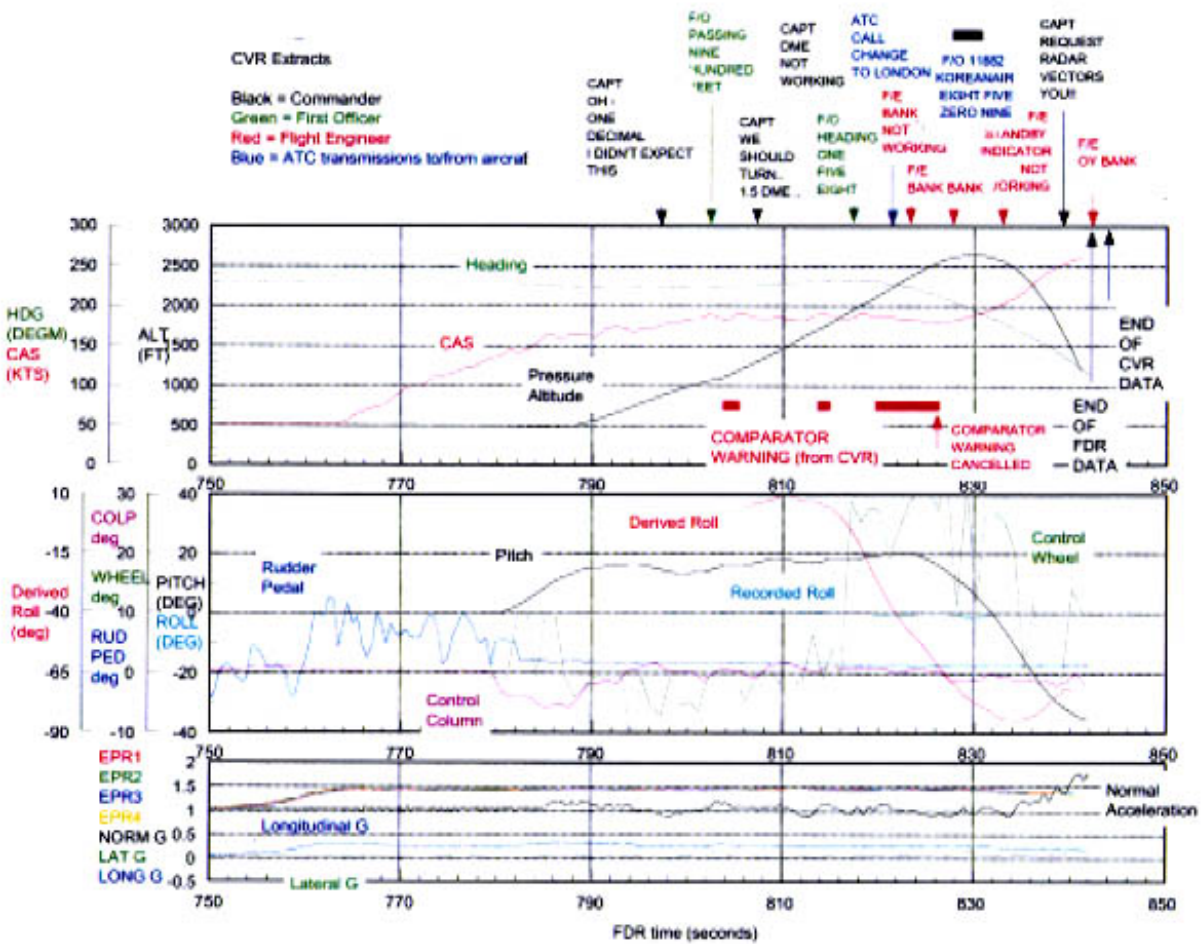

Appendix J

Appendix K - OS map and radar track data

## RADAR PLOT (Stansted Watchman)

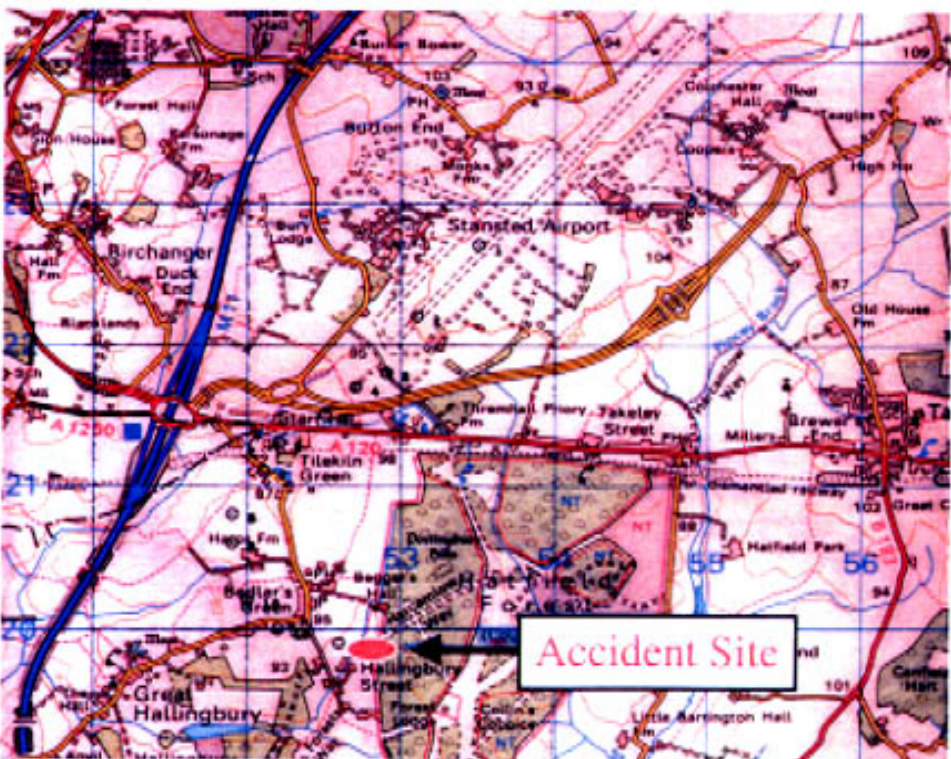

	Time	Height (1013)
1.	1837.47	660 feet
2.	1837.55	960 feet
3.	1837.59	1160 feet
4.	1838.3	1360 feet
5.	1838.7	1660 feet
6.	1838.11	1860 feet
7.	1838.15	2160 feet
8.	1838.19	2360 feet
9.	1838.22	2460 feet
10.	1838.26	2360 feet
11.	1838.30	1960 feet
12.	1838.34	1060 feet

Appendix K

## Appendix L - Figure 1 - Impact parameters

Appendix L  
Figure 1

### SUMMARY OF IMPACT PARAMETERS --- KoreanAir BOEING 747 HL-7451

STANSTED 22 DECEMBER 1999

Angle of bank - 80°/90° left  
Speed Between 250 kt and 300 kt  
38°/40° Nose Down  
Heading 102°M  
T/E Flaps set at 'Flaps 10'  
L/E Slats Extended  
Landing Gear Retracted

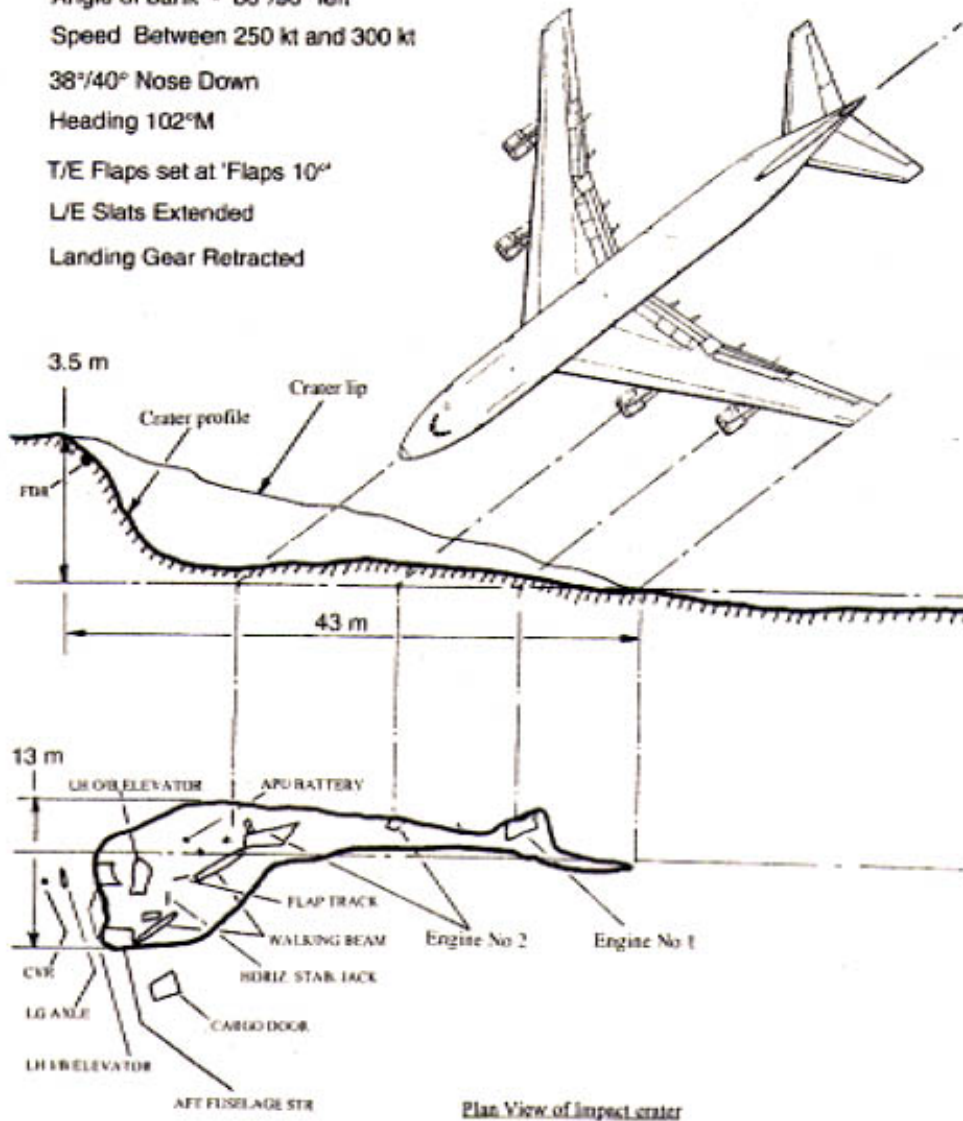

### Appendix I - Figure 2 - Wreckage distribution

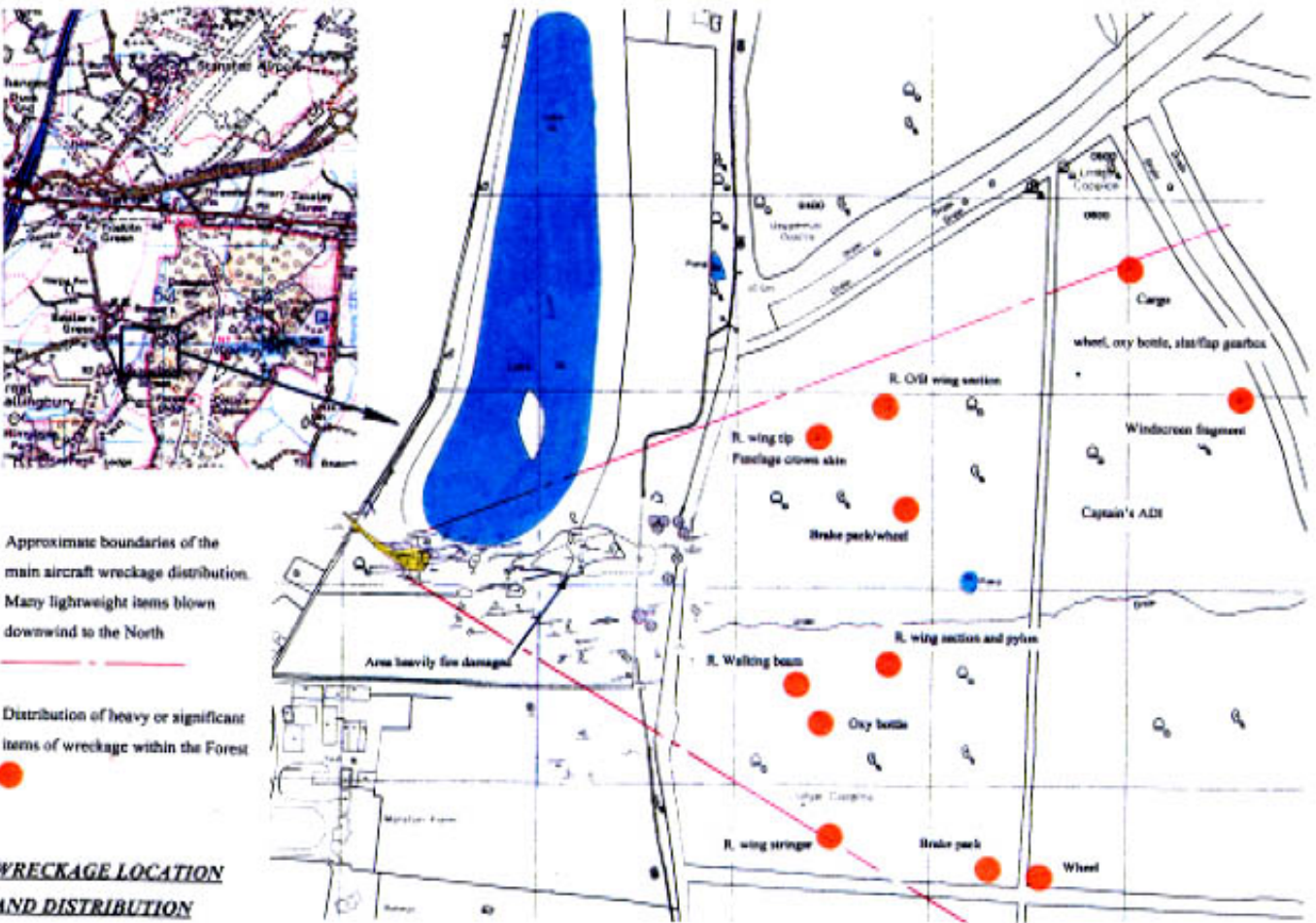

Appendix I  
 Figure 2

**Appendix M - Figure 1 and 2 - Front view of ADI as found**

Appendix M  
Figures 1 and 2

**FRONT VIEW OF INDICATOR AS FOUND**

(Compare with Appendix O Figure 1)



Figure 1



**ASSESSMENT OF INDICATED ROLL ANGLE  
ALLOWING FOR DISTORTION**

Figure 2



## Appendix M - Figures 3 to 6 - Assessment of GYRO Flag Positions

Appendix M  
Figures 3 - 6



Figure 3



Figure 4

GYRO flag in view seen from front and rear

GYRO flag as-found, seen from the front, crimped between the folds of the FDI case sidewall. Angle of flag, in relation to front and top edge of the casing, is similar to the flag out of view position

GYRO flag out of view seen from the rear



Figure 5



Figure 6

ASSESSMENT OF GYRO FLAG POSITION PRIOR TO IMPACT

## Appendix N - Figure 1 - Standard Ground Handling Agreement Section 9

Appendix N  
Figure 1

### SECTION 9. AIRCRAFT MAINTENANCE

#### **9.1 Routine Services**

- 9.1.1 Perform line inspection in accordance with the Carrier's current instructions.
- 9.1.2 Enter in aircraft log and sign for performance of line inspection.
- 9.1.3 Enter remarks in aircraft log regarding defects observed during the inspection.
- 9.1.4
  - (a) Performs pre-departure inspection immediately before aircraft departure according to the Carrier's instructions.
  - (b) Perform ice-check immediately before aircraft departure according to the Carrier's instructions.
- 9.1.5 Provide skilled personnel to assist the flight crew or ground staff in the performance of the inspection.

#### **9.2 Non-routine Services**

- 9.2.1 Rectify defects entered in the aircraft log as reported by the crew or revealed during the inspection, to the extent requested by the Carrier. However, major repairs must be separately agreed upon between the Parties.
- 9.2.2 Enter in aircraft log and sign for the action taken.
- 9.2.3 Report technical irregularities and actions taken to the Carrier's maintenance base in accordance with the Carrier's instructions.
- 9.2.4 Maintain the Carrier's technical manuals, handbooks, catalogues, etc.
- 9.2.5 Provide engineering facilities, tools and special equipment to the extent available.
- 9.2.6 Move aircraft under its own power in accordance with the Carrier's instructions.

#### **9.3 Material Handling**

- 9.3.1
  - (a) Obtain Customs clearance for
  - (b) Administer the Carrier's spare parts, power plants and/or equipment.
- 9.3.2 Provide periodic inspection of the Carrier's spare parts and/or spare power plant.
- 9.3.3 Provide suitable storage space for the Carrier's spare parts and/or special equipment.
- 9.3.4 Provide suitable storage space for the Carrier's spare power plant.

#### **9.4 Parking and Hangar Space**

- 9.4.1
  - (a) Provide
  - or
  - (b) Arrange for suitable parking space.

Figure 1

## Appendix N - Figure 2 - Standard Ground handling Agreement Para 6

Appendix N  
Figure 2

FLS AGREEMENT NO: 2045

DATED: 01/12/1999

### PARAGRAPH 6 – INTERFACE PROCEDURES

- 6.1 FLS Aerospace shall send two mechanics of whom at least one should have FAA, A&P or JAR 145 B747 Licence (hereinafter referred to as the "FLSA crew")
- 6.2 FLS Aerospace shall inform KAL London Maintenance Manager when any change takes place as to equipment and materials which FLSA is to provide to KAL.
- 6.3 The FLS Aerospace crew shall meet the aircraft upon arrival on site and stay with the aircraft until it's departure. If the total downtime of the aircraft exceeds three hours the FLS Aerospace crew may leave the aircraft, subject to the approval KAL Maintenance Manager. In the case the crew leaves the aircraft they will be in permanent contact with the aircraft while it's on the ground.
- 6.4 The four Manhours mentioned in clause 1.1 to this agreement only relates to the FLS Aerospace crew and can not be transferred to any other FLS Aerospace personnel. If the time the FLS Aerospace crew is with the aircraft exceeds a total of four manhours and the Carrier wishes to keep the FLS Aerospace crew with the aircraft or if any additional mechanics are required alongside the FLS Aerospace crew the Manhour rate in clause 1.2 will apply.
- 6.5 The FLS Aerospace crew shall contact the pilots when the aircraft stops at position to inquire the condition of the aircraft, possible by interphone.
- 6.6 The FLS Aerospace crew shall perform transit check in accordance with KAL transit check sheet.
- 6.7 The FLS Aerospace crew shall inform the KAL Maintenance Manager of defect as soon as they find it for instructions.
- 6.8 The FLS Aerospace crew shall brief the KAL Maintenance Manager on the condition of the aircraft after completion of check and/or defect rectification's if such are to be carried out during check. Then do the same briefing on pilots.
- 6.9 After doors are closed, the FLS Aerospace crew shall make contact with pilots for engine start and confirm that conditions are normal, possible by interphone.

**Figure 2**

Appendix O - Figure 1 - Diagram of Captain's FDI presentations

Appendix O



Captain's FDI

DIAGRAM OF ESTIMATED FDI PRESENTATION AT MOMENT OF IMPACT

Yellow command bars drawn at maximum normal fly UP (15°) and RIGHT (20°) position, roll attitude indicating approx. 2.5° LEFT roll  
(White command bars represent as-found position, derived from FDI strip examination)

Figure 1



Captain's FDI

DIAGRAM OF PRESENTATION WITH 0° PITCH ATTITUDE LINE AT INTERSECTION OF FIXED BLUE SEGMENT AND UPPER VISIBLE LIMIT OF ATTITUDE TAPE

Yellow command bars drawn at maximum normal fly UP (15°) and RIGHT (20°) position, roll attitude indicating approx. 2.5° LEFT roll

Figure 2

## Appendix P - Diagram of estimated Captain and First Officer's FDI presentations

Appendix P



Captain's FDI



First Officer's FDI

### DIAGRAM OF ESTIMATED FDI PRESENTATIONS AT MOMENT OF IMPACT

Yellow command bars drawn at maximum normal fly UP (15°) and RIGHT (20°) roll  
(White command bars represent as-found position, derived from FDI strip examination)

Figure 1

Figure 2

## Appendix Q - Attitude reference at moment of impact

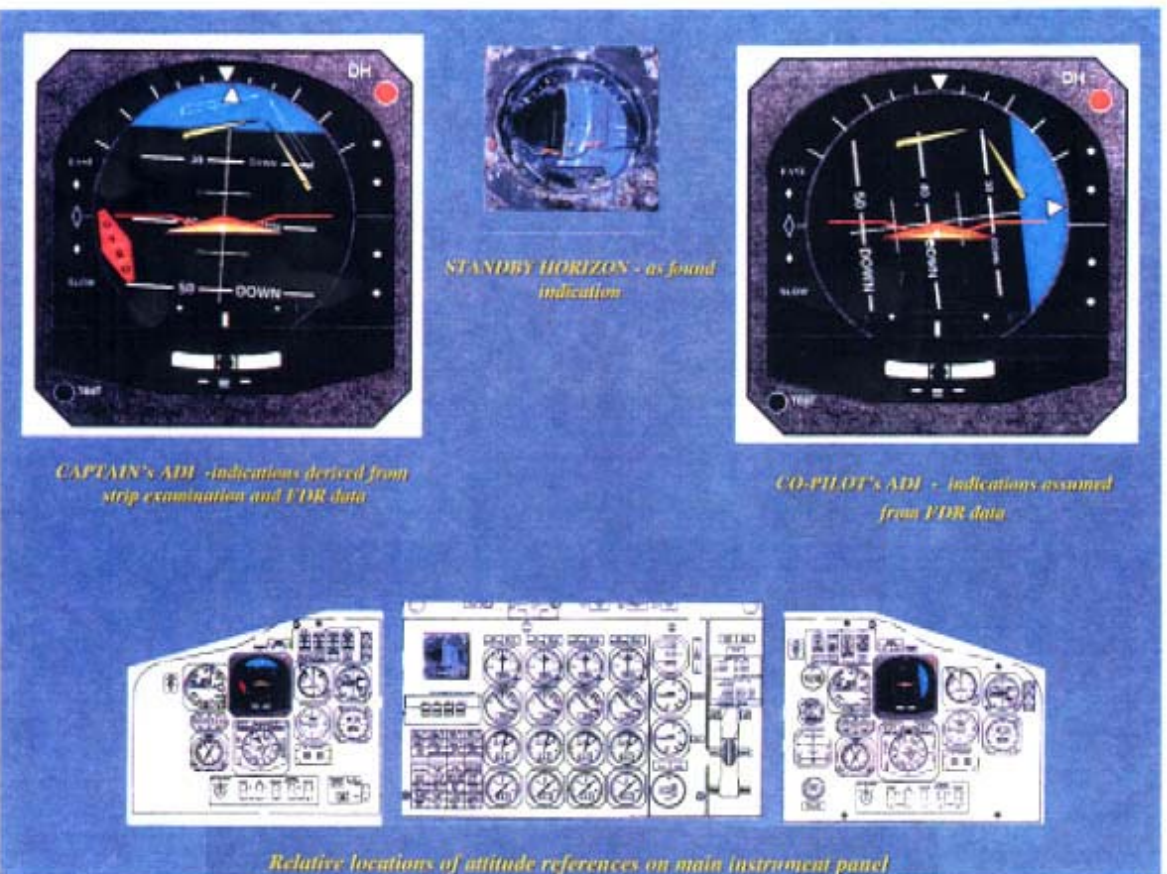

Attitude Reference Data at Moment of Impact